



**ROHDE & SCHWARZ**

Broadcasting  
Division

**Operating Manual**

**TV Analyzer**

**R&S<sup>®</sup> FSH3-TV**

**2111.7005.63**

Dear Customer,

R&S® is a registered trademark of Rohde & Schwarz GmbH & Co. KG.  
Trade names are trademarks of the owners.

# Contents

**Specifications**  
**Safety Instructions**  
**Certificate of Quality**  
**EC-Certificate of Conformity**  
**Support Center Address**  
**List of R&S Representatives**

<b>1 Putting into Operation</b> .....	1.1
<b>Front view</b> .....	1.1
<b>Putting into Operation</b> .....	1.2
Unpacking the Instrument.....	1.2
Setting up the Instrument.....	1.3
Switching on the TV Analyzer .....	1.4
TV Analyzer Connectors .....	1.5
Screen Settings.....	1.7
Country-Specific Settings.....	1.9
Setting the Date and Time .....	1.10
Setting the date .....	1.10
Setting the time .....	1.10
<b>Charging the Battery</b> .....	1.11
<b>Selecting the Instrument Default Setup</b> .....	1.12
<b>Multifunctional BNC Connector Control</b> .....	1.13
<b>Controlling the RF Attenuator</b> .....	1.14
<b>Using a Preampifier</b> .....	1.15
<b>PIN Entry</b> .....	1.16
<b>Connecting a Printer</b> .....	1.18
<b>Setting the Baud Rate for Remote Control</b> .....	1.20
<b>Enabling Options</b> .....	1.20
<b>Checking the Installed Options</b> .....	1.21

<b>2 Getting Started</b> .....	2.1
<b>Measurements with the Spectrum Analyzer</b> .....	2.1
Sinewave Signal Measurement .....	2.1
Level Measurement .....	2.1
Setting the Reference Level.....	2.2
Frequency Measurements .....	2.3
Harmonic Measurements of a Sinewave Signal .....	2.4
<b>Measurements on Analog TV Signals</b> .....	2.5
Measuring the Video-Signal-to-Noise Ratio.....	2.5
Measurements Using the Video Oscilloscope .....	2.11
Measuring the Vision Carrier Modulation Depth .....	2.14
Measuring the Carrier Levels and Carrier Frequencies.....	2.17
Measuring the Hum Modulation .....	2.19
<b>Measurements on Digital TV Signals</b> .....	2.21
Measuring the Transmission Parameters.....	2.21
I/Q Constellation Display.....	2.25
Measuring the Shoulder Attenuation of a QAM Signal .....	2.26
Measuring the Shoulder Attenuation of an 8-VSB/ATSC Signal.....	2.28
Measuring the Shoulder Attenuation of a DVB-T Signal (ETSI TR 101 290) .....	2.30
<b>Measuring the Carrier-to-Noise Ratio</b> .....	2.33
Reference power/reference level .....	2.34
Measuring the noise power.....	2.35
<b>Measurements on Cable TV Systems</b> .....	2.36
Measuring the Composite Triple Beat Ratio .....	2.36
Measuring the Reference Power .....	2.38
Measuring the Composite Triple Beat Distortion .....	2.39
Measuring the Composite Second Order Ratio .....	2.41
Measuring the Reference Power .....	2.42
Measuring the Composite Second Order Distortion .....	2.44
Measuring the Frequency Response of the Cable TV System .....	2.46
<b>Power Measurements Using the Power Sensor</b> .....	2.50
<b>Measurements Using the Tracking Generator</b> .....	2.52
Power and Return Loss Measurements with the R&S FSH-Z14 or the R&S FSH-Z44.....	2.52
Two-Port Transmission Measurements.....	2.54
Measurement of Return Loss .....	2.56
Performing Distance-To-Fault Measurements.....	2.59

**Operation in Receiver Mode** .....2.65

**Saving and Recalling Settings and Test Results** .....2.70

    Saving Measurement Results .....2.70

    Saving Calibration Data .....2.71

    Recalling Measurement Results .....2.72

**Printing Out Measurement Results** .....2.74

<b>3 Operation and menu overview</b> .....	3.1
<b>Entering Parameters</b> .....	3.1
Entering values and texts.....	3.1
Entering units .....	3.2
<b>Menu Overview</b> .....	3.3
Instrument setup .....	3.3
Status display.....	3.4
Save and print-menu.....	3.4
Limit line menus.....	3.4
Transducer menus.....	3.5
Spectrum analyzer .....	3.5
Frequency entry .....	3.5
Frequency span entry .....	3.5
Level entry.....	3.5
Bandwidth entry.....	3.6
Sweep entry .....	3.6
Trace settings .....	3.7
Markers .....	3.7
Analog TV receiver .....	3.9
FREQ key.....	3.11
AMPT key.....	3.11
BW key.....	3.11
SWEEP key .....	3.12
TRACE key .....	3.13
MARKER key .....	3.14
Digital TV receiver (options R&S FSHTV-K21, R&S FSHTV-K22).....	3.15
FREQ key.....	3.16
SPAN key.....	3.16
AMPT key.....	3.16
BW key.....	3.17
SWEEP key .....	3.17
TRACE key .....	3.18
Cable-TV analyzer .....	3.19
FREQ key.....	3.20
SPAN key.....	3.20
AMPT key.....	3.21
BW key.....	3.21
SWEEP key .....	3.21
TRACE key .....	3.21
MARKER key .....	3.21
Measurement functions .....	3.22
Power sensor menus .....	3.23

Receiver mode (option R&S FSH-K3) .....3.24

    FREQ key.....3.24

    SPAN key.....3.25

    AMPT key.....3.25

    Bandwidth entry.....3.25

    Sweep key.....3.26

    TRACE key .....3.26

<b>4 Instrument Functions</b> .....	4.1
<b>Instrument Default Setup</b> .....	4.1
<b>Status Display</b> .....	4.1
<b>Spectrum Analyzer</b> .....	4.2
Screen Layout .....	4.2
Setting the Frequency .....	4.2
Entering the center frequency .....	4.2
Setting a frequency offset .....	4.4
Entering the center-frequency stepsize .....	4.4
Entering the start and stop frequency .....	4.5
Working with channel tables .....	4.6
Setting the Span .....	4.7
Setting the Amplitude Parameters .....	4.8
Setting the reference level .....	4.9
Entering the display range .....	4.10
Entering the display unit .....	4.10
Entering the reference offset .....	4.11
Entering the input impedance .....	4.11
Setting the Bandwidths .....	4.12
Resolution bandwidth .....	4.12
Video bandwidth .....	4.14
Setting the Sweep .....	4.16
Sweep time .....	4.16
Sweep mode .....	4.17
Trigger .....	4.17
Trace Settings .....	4.20
Trace mode .....	4.20
Detector .....	4.22
Trace memory .....	4.24
Using the Markers .....	4.25
Automatic marker positioning .....	4.26
Using more than one marker at a time (multimarker mode) .....	4.28
Marker functions .....	4.32
Measuring the noise power density .....	4.32
Measuring the frequency .....	4.33
AF demodulation .....	4.33
Using the Display Line .....	4.35



<b>Operation as an Analog TV Receiver</b> .....	4.36
Setting the Analog TV Standard .....	4.37
Setting the Receive Frequency .....	4.39
Frequency Tuning in Channel Spacings .....	4.41
Selecting the Sideband .....	4.42
Manual Setting of the Reference Level .....	4.43
Selecting the Reference Level Unit .....	4.43
Entering the Reference Offset .....	4.43
Entering the Input Impedance .....	4.44
Inputting the Display Range .....	4.44
Setting the Unit for the Video Amplitude .....	4.44
Automatic Routine for Setting the Optimum Reference Level .....	4.45
Measuring the Video Transmission Parameters Using Test Line Measuring Equipment.....	4.45
Test Lines .....	4.46
Setting the Test Lines .....	4.48
Video Output .....	4.49
Audio Output .....	4.50
Measurement Parameter List .....	4.53
Screen Layout .....	4.53
Switching on the Measurement Parameter List .....	4.57
Level Adjust.....	4.58
Video Oscilloscope .....	4.59
Screen Layout .....	4.59
Switching on the Video Oscilloscope .....	4.59
Level Adjust.....	4.60
Setting the Time Basis .....	4.60
Setting the Horizontal Position .....	4.60
Triggering in the Video Scope Operating Mode .....	4.61
Markers in the Video Scope Operating Mode .....	4.63
Automatic Positioning of the Marker .....	4.64
Unit for the Delta Marker .....	4.65
Trace Modes .....	4.66
Trace Memory .....	4.67
Measuring the Vision Carrier Modulation .....	4.68
Definitions of the Measurement Parameters .....	4.68
Screen Layout .....	4.68
Switching on Vision Modulation Operating Mode .....	4.69
Level Adjust.....	4.69
Setting the Unit for the Vision Carrier Power .....	4.69
Displaying the Measurement Parameters .....	4.70
Triggering in Vision Modulation Operating Mode .....	4.70
Setting the Time Basis .....	4.73
Markers in the Vision Modulation Operating Mode .....	4.74
Trace Modes .....	4.75
Trace Memory .....	4.77

Measuring the Carrier Levels and Carrier Frequencies .....	4.78
Screen Layout .....	4.78
Switching on the Carrier Measurements Operating Mode .....	4.79
Level Adjust.....	4.80
Setting the Unit for the Vision Carrier Level .....	4.80
Measuring the Hum Modulation .....	4.81
Definition of Hum Modulation .....	4.81
Screen Layout .....	4.81
Switching on the Hum Measurement Operating Mode .....	4.82
Level Adjust.....	4.82
Triggering in Hum Measurement Operating Mode .....	4.83
Setting the Time Basis .....	4.85
Markers .....	4.85
Trace Functions .....	4.86
<b>Operation as a Digital TV Receiver .....</b>	<b>4.88</b>
Setting the Digital TV Standard.....	4.89
Setting the Receive Frequency.....	4.89
Frequency Tuning in Channel Spacings .....	4.90
Setting the Reference Level.....	4.92
Manual Entry of the Reference Level.....	4.92
Selecting the Reference Level Unit.....	4.92
Entering the Reference Offset .....	4.92
Entering the Input Impedance.....	4.93
Inputting the Display Range .....	4.93
Automatic Routine for Setting the Optimum Reference Level .....	4.94
Setting the QAM Order .....	4.94
Setting the Symbol Rate .....	4.95
Selecting the Sideband .....	4.95
TS-ASI Output.....	4.96
Measurement Parameter List .....	4.97
Instrument Settings .....	4.97
Measurement Parameters .....	4.98
Switching on the Measurement Parameter List .....	4.99
Level Adjust.....	4.100
Restart Measure .....	4.100
Selecting the Unit for Power Measurement of the Digital TV Signal.....	4.100
Constellation Diagram.....	4.101
Screen Layout .....	4.101
Parameters .....	4.101
Switching on the Constellation Diagram Operating Mode.....	4.102
Level Adjust.....	4.103
Restart Measure .....	4.103
Selecting the Unit for Power Measurement of the Digital TV Signal.....	4.103
Trace Functions .....	4.103

Measuring the Shoulder Attenuation.....	4.105
Shoulder Attenuation Measurement in Compliance with ETSI TR 101 290 .....	4.105
Shoulder Attenuation Measurement for 8VSB Signals (FCC Recommendation) .....	4.106
Screen Layout .....	4.107
Switching on the Shoulder Attenuation Operating Mode .....	4.107
Level Adjust.....	4.108
Setting the Unit for the Measured Channel Power.....	4.108
Displaying the Shoulder Attenuation Parameters .....	4.109
Setting the Channel Bandwidth.....	4.109
Setting the Resolution Bandwidth .....	4.110
Setting the Video Bandwidth .....	4.110
Setting the Detector .....	4.110
Trace Functions .....	4.111
<b>Measurements with the Cable TV Analyzer .....</b>	<b>4.113</b>
Activating the CTB or CSO Measurement .....	4.113
Determining the Reference.....	4.114
Screen Layout for the Reference Measurement.....	4.114
Setting the Channel Bandwidth.....	4.114
Setting the Reference Channel.....	4.115
Setting the Reference Level.....	4.116
Measuring the Reference for Vision Carriers with Negative Modulation.....	4.116
Measuring the Reference for Vision Carriers with Positive Modulation .....	4.117
Averaging of Measured Values .....	4.118
Manually Determining the Reference.....	4.118
Selecting the Unit for the Reference .....	4.119
Blanking Out the Reference.....	4.119
Measuring the Composite Triple Beat Interference .....	4.120
Screen Layout for the CTB Measurement .....	4.120
Activating the CTB Measurement .....	4.120
Setting the CTB Receive Channel .....	4.121
Changing the CTB Measurement Channel.....	4.122
Setting the Reference Level.....	4.122
Trace Functions .....	4.123
Blanking Out the CTB Measured Value .....	4.124
Measuring the Composite Second Order Interference .....	4.125
Screen Layout for the CSO Measurement.....	4.125
Activating the CSO Measurement.....	4.125
Setting the CSO Receive Channel.....	4.126
Changing the Carrier Offset.....	4.127
Changing the CSO Measurement Channel .....	4.127
Setting the Reference Level.....	4.128
Trace Functions .....	4.128
Blanking Out the CSO Measured Value .....	4.129

<b>Measuring the Carrier-to-Noise Ratio</b> .....	4.130
Determining the reference .....	4.132
DIGITAL Tx mode.....	4.132
ANALOG TV mode .....	4.133
CW Tx mode.....	4.134
Manual reference mode .....	4.134
Setting the reference channel .....	4.135
Setting the reference channel bandwidth.....	4.135
Setting the analyzer reference level for the reference channel measurement.....	4.136
Inserting the C/N reference.....	4.137
Units of the C/N reference .....	4.137
Measuring the noise channel power and calculating the carrier power/noise power.....	4.138
Setting the noise channel.....	4.139
Setting the noise channel bandwidth .....	4.139
Setting the reference level during noise channel measurement.....	4.140
Selecting the C/N result display .....	4.140
C/N measurement result display.....	4.141
Changing the span.....	4.141
<b>Measuring the channel power of continuously mod. signals</b> .....	4.142
Selecting the standard .....	4.143
Setting the reference level .....	4.145
Setting the channel bandwidth .....	4.145
Changing the span.....	4.146
Power display.....	4.146
<b>Power measurements on TDMA signals</b> .....	4.148
Selecting a standard .....	4.149
Setting the measurement time.....	4.150
Optimizing the reference level .....	4.151
Power readout.....	4.151
Setting the trigger.....	4.152
<b>Measuring the occupied bandwidth</b> .....	4.153
Selecting a standard .....	4.154
Setting the reference level .....	4.156
Setting the channel bandwidth .....	4.156
Displaying the occupied bandwidth.....	4.157
Changing the span.....	4.157

<b>Using the Receiver mode (option R&amp;S FSH-K3)</b> .....	4.157
Setting the frequency .....	4.158
Setting the reference level .....	4.162
Setting the bandwidth.....	4.162
Setting the detector.....	4.163
Setting the measurement time.....	4.164
Measurement on multiple frequencies or channels (scan).....	4.164
<b>Working with the Preselector R&amp;S FSHTV-Z60</b> .....	4.166
Automatic detection of the preselector .....	4.167
Automatic calibration.....	4.167
Selecting the signal path.....	4.169
Attenuator control.....	4.169
Working with the preamplifier .....	4.170
<b>Measurements using the power sensor</b> .....	4.171
Connecting the power sensor .....	4.171
Zeroing the power sensor .....	4.174
Selecting the unit for the power readout .....	4.174
Setting the averaging time .....	4.175
Taking additional loss or gain into account.....	4.176
<b>Measuring forward and reflected power</b> .....	4.176
Zeroing the power sensor .....	4.179
Setting the power measurement weighting.....	4.179
Selecting the unit for the power readout .....	4.180
Taking additional attenuation into account.....	4.182
<b>Two-port measurements with the tracking generator</b> .....	4.183
Measuring the transfer function of two-ports .....	4.185
Scalar measurement of transfer function.....	4.185
Vector measurement of transfer function.....	4.188
Reflection measurements .....	4.190
Scalar measurement of reflection .....	4.190
Vector measurement of reflection.....	4.193
Display of reflection in vector measurement.....	4.195
<b>One-Port Measurement of Cable Loss</b> .....	4.198

<b>Cable Measurements</b> .....	4.199
Cable selection .....	4.200
Selecting the frequency range .....	4.203
Calibrating the test setup .....	4.204
Locating cable faults by means of the marker function .....	4.207
Measuring spectrum and reflection.....	4.210
Further information .....	4.212
Setting the span .....	4.212
Selecting the center frequency.....	4.213
Measurement .....	4.213
Length measurement accuracy.....	4.213
<b>Using Limit Lines</b> .....	4.214
Measurements with limit lines .....	4.216
Definition range of limit lines .....	4.217
Data sets containing limit lines.....	4.217
<b>Measuring with Transducer Factors</b> .....	4.218
Unit for measurements with transducers .....	4.220
Reference level settings for measurements with transducers .....	4.220
Frequency range of transducer .....	4.221
Data sets containing transducer factors .....	4.221
<b>Saving and Loading Instrument Settings and Measurement Results</b> .....	4.222
Saving results .....	4.222
Entering a data set name.....	4.223
Loading measurement results .....	4.224
Deleting saved data sets.....	4.225
Deleting all data sets.....	4.225
<b>Printing out Measurement Results</b> .....	4.226
<b>How a spectrum analyzer operates</b> .....	4.227

## Specifications

Specifications are valid under the following conditions: 15 minutes warm-up time at ambient temperature, specified environmental conditions met and calibration cycle adhered to. Data without tolerances: typical values. Data designated as "nominal": design parameters, i.e. not tested.

### Frequency

Frequency range	100 kHz to 3 GHz
Reference frequency	
Aging	1 ppm/year
Temperature drift	2 ppm ( 0 to 30 °C), in addition 2ppm/10°C (30 to 50°C)
Frequency counter	
Resolution	1 Hz
Frequency span	100 Hz to 3 GHz, 0 Hz

### Spectral purity

SSB phase noise, f = 500 MHz, 20 to 30 °C	
30 kHz from carrier	< 85 dBc/1Hz
100 kHz from carrier	< 100 dBc/1Hz
1 MHz from carrier	< 120 dBc/1Hz

### Inputs

RF input	N female
Input impedance	50 Ω
VSWR (10 MHz to 3 GHz)	typ. 1.5
Maximum permissible DC voltage at RF input	80 V
Maximum power	20 dBm, 30 dBm (1 W) for max. 3 minutes
Trigger/external reference input	BNC female, selectable, same connector as video and TS-ASI output
Trigger voltage	TTL
Reference frequency	10 MHz
Required level from 50 Ω	10 dBm

### Outputs

Tracking generator	N female
Frequency range	5 MHz to 3 GHz
Output level	0 dBm / -20 dBm, selectable
Output impedance	50 Ω
Video output (Analog TV receiver mode)	BNC female, selectable, same connector as Trigger/external reference input and TS-ASI output
Output level	1 V
DC position back porch	0 V
Output impedance	75 Ω
TS-ASI output (Digital TV receiver mode) (option R&S FSHTV-K21, R&S FSHTV-22)	BNC female, selectable, same connector as Trigger/external reference input and video output
Output level, peak-peak	0.8 V
Data rate	270 Mbit/s
Output impedance	75 Ω

AF output	3.5 mm mini jack
Spectrum analyzer mode	AM (video voltage without AGC) and FM
Analog TV receiver mode	Acc. to standard
Output impedance	100 $\Omega$
Output level	adjustable

### Analog TV Receiver

Standards	B, G, H, D, K, I, L, M, N,
Sound standards	IRT-A2, NICAM, BTSC, EIA-J, Korea-Stereo
Video bandwidth, acc. to standard	4 MHz, 5 MHz, 5.5 MHz and 6 MHz
Measurements	Vision carrier power Vision carrier frequency offset Vision / sound carrier power ratio Vision / sound carrier frequency offset Luminance bar amplitude Video S/N, weighted acc. to CCIR Rec. 567 Audio mode NICAM bit error ratio Vision modulation depth, residual picture carrier Video scope Hum modulation Carrier to noise power ratio
Measurement uncertainty	
Video S/N, weighted acc. to CCIR Rec. 567 (1 channel)	
S/N < 45 dB	< 1 dB typ.
S/N 45 ... 55 dB	< 3 dB typ.

### Cable TV Analyzer

Measurements	Composite Tripple Beat (CTB) ratio Composite Second Order (CSO) ratio
--------------	--

### Digital TV Receiver (options R&S FSHTV-K21, R&S FSHTV-K22)

QAM standards (option R&S FSHTV-K21)	DVB-C, J.83/A /B /C (Europe, US and Japanese cable TV)
QAM order	4-, 16-, 32-, 64-, 128- and 256-QAM
Bandwidth, acc. to symbol rate	6 MHz, 7 MHz and 8 MHz
Symbol rate	2 ... 6.999 MHz
8-VSB/ATSC standard (Option R&S FSHTV-K22)	
Bandwidth	6 MHz
Symbol rate	10.672238 MHz
Measurements	Channel power Carrier frequency offset Pilot carrier power and frequency (8-VSB/ATSC) Symbol rate offset MER (Modulation Error Ratio) (MER measurement range up to 40 dB) EVM (Error Vector Magnitude)



Measurements	Bit Error Ratio before RS Decoder Packet Error Ratio respectively Segment Error Ratio Transport stream rate Constellation diagram Shoulder attenuation acc. to ETSI TR 101 290 (QAM) respectively acc. to FCC (8-VSB/ATSC) Carrier to noise power ratio
Measurement uncertainty	
Carrier frequency offset	< 5 ppm, referred to carrier frequency
Symbol rate offset	< 5 ppm, referred to symbol rate
Modulation Error Ratio (Equalizer on, 1 channel)	
MER < 33 dB	typ. < 1 dB
MER 33 ... 38 dB	typ. < 3 dB
Error Vector Magnitude	
EVM > 1.5 %	typ. < 12 % of measured value
EVM 0.9 ... 1.5 %	typ. < 40 % of measured value
Transport stream rate	< 5 ppm

## Spectrum Analyzer

### Bandwidth

Resolution bandwidths (-3 dB)	100 Hz to 1 MHz in 1, 3 steps, in addition 200 kHz
Tolerance ≤ 300 kHz	± 5 %, nominal
Tolerance 1 MHz	± 10 %, nominal
Resolution bandwidths (-6 dB) with option R&S FSH-K3 installed	in addition 200 Hz, 9 kHz, 120 kHz
Video bandwidth	10 Hz to 3 MHz in 1, 3 steps

### Sweep time

Span > 0 Hz	20 ms to 1000 s, min. 20 ms / 600 MHz
Span = 0 Hz	1 ms to 100 s

### Display range

Intermodulation-free dynamic range	average noise level displayed to +20 dBm
third-order IM products, 2 x -20 dBm, reference level = -10 dBm third-order intercept	66 dB +13 dBm
Displayed average noise level, average value, resolution bandwidth 1 kHz, video bandwidth 10 Hz, reference level ≤ -30 dBm 10 MHz to 3 GHz	<-105 dBm, typ. -114 dBm
With preamplifier 10 MHz to 2.5 GHz 2.5 to 3 GHz	<-120 dBm, typ. -125 dBm <-115 dBm, typ. -120 dBm
Inherent spurious, reference level ≤ -20 dBm, f > 30 MHz, RBW ≤ 100 kHz	<-80 dBm
Input related spurious carrier offset > 1 MHz	<-70 dBc, nominal
2nd harmonic	typ. <-60 dBc
Signal frequency minus 2.0156 GHz for signal frequencies 2 GHz to 3.2 GHz	typ. <-55 dBc

**Level display**

Reference level	-80 to +20 dBm in steps of 1 dB
Display range	100 dB, 50 dB, 20 dB, 10 dB, 1 dB, linear
Display units	
Logarithmic	dBm, dB $\mu$ V, dBmV with transducer also dB $\mu$ V/m and dB $\mu$ A/m
Linear	$\mu$ V, mV, V, nW, $\mu$ W, mW, W with transducer also V/m, mV/m, $\mu$ V/m and W/m <sup>2</sup>
Traces	1 trace and 1 memory trace
Detectors	auto peak, maximum peak, minimum peak, sample, RMS
Level measurement error, frequency > 1 MHz, at reference level down to -50 dB, 20 °C to 30 °C	< 1.5 dB, typ. 0.5 dB
<b>Markers</b>	
Number of markers or delta markers	maximal 6
Marker functions	peak, next peak, minimum, center = marker frequency, reference level = marker level, all markers to peak
Marker displays	normal (level), noise marker, frequency counter (count)
<b>Trigger</b>	free-running, video, external

**Transmission measurements**

Frequency range	10 MHz to 3 GHz
Dynamic range	
10 MHz to 2.2 GHz	
scalar mode	60 dB
vector mode, option R&S® FSH-K2	80 dB
2.2 GHz to 3 GHz	
scalar mode	50 dB
vector mode, option R&S® FSH-K2	65 dB

**Interfaces**

Optical Interface, Baudrate	1200, 2400, 9600, 19200, 38400, 57600 baud
Control Interface, Control and Supply of Power Sensor and Preselector	7-contact female connector (type Binder 712)

**Accessories****Preselector R&S FSHTV-Z60**

RF input	F connector (F male with adapter F female / F female)
Input impedance	75 $\Omega$
VSWR, bypass path	typ. 1.5
VSWR, filter path, RF attenuator $\geq$ 5 dB	typ. 1.5
Maximum permissible DC voltage	80 V
Maximum power	+20 dBm
Frequency range of filter path	100 kHz to 1 GHz
Frequency range of bypass path	100 kHz to 3 GHz
Preamplifier	100 kHz to 3 GHz, selectable

RF output	N male
Output impedance	50 $\Omega$
Power consumption	500 mW
Dimensions	169 x 116 x 30 mm
Weight	500 g

#### Power Sensors R&S FSH-Z1 and R&S FSH-Z18

Frequency range	R&S FSH-Z1	10 MHz to 8 GHz
	R&S FSH-Z18	10 MHz to 18 GHz
VSWR		
	10 MHz to 30 MHz	< 1.15
	30 MHz to 2.4 GHz	< 1.13
	2.4 GHz to 8 GHz	< 1.20
	8 GHz to 18 GHz	< 1.25
Maximum input power		400 mW (+26 dBm), average power 1 W (+30 dBm), peak power (<10 $\mu$ s, 1% duty cycle)
Measurement range		200 pW to 200 mW (-67 to +23 dBm)
Signal weighting		average power
	Effect of harmonics	< 0.5 % (0.02 dB) at harmonic ratio of 20 dB
	Effect of modulation	< 1.5 % (0.07 dB) for continuous digital modulation
Absolute measurement uncertainty (sine signals, no zero offset)		
	10 MHz to 8 GHz	15 °C to 35 °C < 2.5 % (0.11 dB) 0 °C to 50 °C < 4.5 % (0.19 dB)
	8 GHz to 18 GHz	15 °C to 35 °C < 3.5 % (0.15 dB) 0 °C to 50 °C < 5.0 % (0.21 dB)
Zero offset after zeroing		< 110 pW
Dimensions		48 mm x 31 mm x 170 mm, connecting cable 1.5 m
Weight		< 0.3 kg

#### Directional Power Sensor R&S FSH-Z14

Frequency range	25 MHz to 1 GHz	
Power measurement range	30 mW to 300 W	
VSWR referenced to 50 $\Omega$	< 1.06	
Power-handling capacity, depending on temperature and matching (see diagram below)	100 W to 1000 W	
Insertion loss	< 0.06 dB	
Directivity	> 30 dB	
Average power		
Power measurement range		
	CW, FM, PM, FSK, GMSK	30 mW to 300 W
	Modulated signals	30 mW to 300 W / CF
	CF: ratio of peak envelope power to average power	
Measurement uncertainty		
	sine signal, 18 °C to 28 °C, no zero offset	
	25 MHz to 40 MHz	4.0 % (0.17 dB) of measured value
	40 MHz to 1 GHz	3.2 % (0.14 dB) of measured value
Zero offset after zeroing		+/- 4 mW

Range of typical modulation	measurement error with	
FM, PM, FSK, GMSK		0 % of measured value (0 dB)
AM (80 %)		± 3 % of measured value (± 0.13 dB)
2 CW carriers with identical power		± 2 % of measured value (± 0.09 dB)
EDGE, TETRA		± 0.5 % of measured value (± 0.02 dB), if standard is selected on the R&S FSH3-TV
Temperature coefficient		
25 MHz to 40 MHz		0.40 %/K (0.017 dB/K)
40 MHz to 1 GHz		0.25 %/K (0.011 dB/K)
Peak envelope power		
Power measurement range		
Video bandwidth 4 kHz		0.4 W to 300 W
200 kHz		1 W to 300 W
600 kHz		2 W to 300 W
Measurement uncertainty, 18°C to 28°C		same as for average power plus effect of peak hold circuit
Error limits of peak hold circuit for burst signals		
Duty cycle ≥ 0.1 and repetition rate ≥ 100/s		
video bandwidth 4 kHz		±(3 % of measured value + 0.05 W) starting from a burst width of 200 μs
200 kHz		±(3 % of measured value + 0.20 W) starting from a burst width of 4 μs
600 kHz		±(7 % of measured value + 0.40 W) starting from a burst width of 2 μs
20/s ≤ repetition rate <100/		plus ±(1.6 % of measured value + 0.15 W)
0.001 ≤ duty cycle < 0.1		plus ±0.10 W
Temperature coefficient		
25 MHz to 40 MHz		0.50 %/K (0.022 dB/K)
40 MHz to 1 GHz		0.35 %/K (0.015 dB/K)
Load matching		
Matching measurement range		
Return loss		0 dB to 23 dB
VSWR		>1.15
Minimum forward power		0.06 W
specs met from 0.4 W		
Error limits for matching measurements		

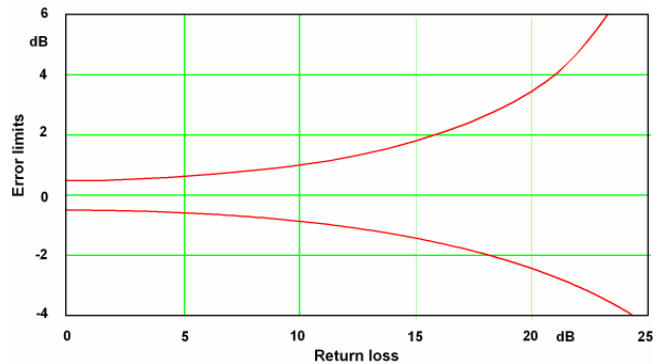

Power-handling capacity

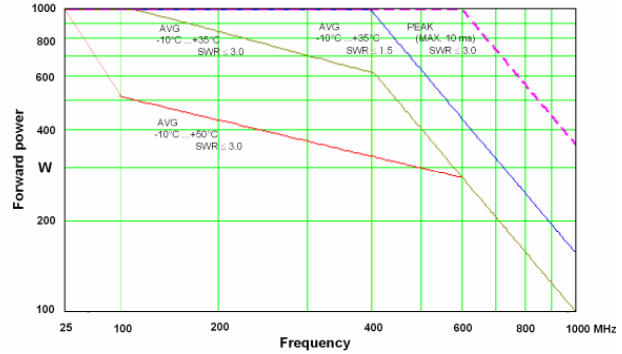

Dimensions

120 mm x 95 mm x 39 mm, connecting cable 1.5 m

Weight

0.65 kg

**Directional Power Sensor R&S FSH-Z44**

Frequency range	200 MHz to 4 GHz
Power measurement range	30 mW to 120 W (300 W with unmodulated envelope)
VSWR referenced to 50 Ω	
200 MHz to 3 GHz	< 1.07
3 GHz to 4 GHz	< 1.12
Power-handling capacity, depending on temperature and matching (see diagram below)	120 W to 1000 W
Insertion loss	
200 MHz to 1.5 GHz	< 0.06 dB
1.5 GHz to 4 GHz	< 0.09 dB
Directivity	
200 MHz to 3 GHz	> 30 dB
3 GHz to 4 GHz	> 26 dB
Average power	
Power measurement range	
CW, FM, PM, FSK, GMSK	30 mW to 300 W
3GPP W-CDMA, cdmaOne, cdma2000, DAB, DVB-T	30 mW to 120 W
Other modulated signals	30 mW to 300 W / CF
CF: ratio of peak envelope power to average power	
Measurement uncertainty, sine signal, 18 °C to 28 °C, no zero offset	
200 MHz to 300 MHz	4.0 % (0.17 dB) of measured value
300 MHz to 4 GHz	3.2 % (0.14 dB) of measured value
Measurement uncertainty after zeroing	+/- 4 mW
Range of typical measurement error with modulation	
FM, PM, FSK, GMSK	0 % of measured value (0 dB)
AM (80 %)	+/- 3 % of measured value (+/- 0.13 dB)
2 CW carriers with identical power	+/- 2 % of measured value (+/- 0.09 dB)
π/4-DQPSK	+/- 2 % of measured value (+/- 0.09 dB)
EDGE	+/- 0.5 % of measured value (+/- 0.09 dB) *)
cdmaOne, DAB	+/- 1 % of measured value (+/- 0.04 dB) *)
3GPP W-CDMA, cdma2000	+/- 2 % of measured value (+/- 0.09 dB) *)
DVB-T	+/- 2 % of measured value (+/- 0.09 dB) *)
Temperature coefficient	
200 MHz to 300 MHz	0.50 %/K (0.022 dB/K)
300 MHz to 4 GHz	0.35 %/K (0.015 dB/K)

\*) if standard is selected on the R&S® FSH3-TV

Peak envelope power

Power measurement range

DAB, DVB-T, cdmaOne, cdma2000, 3GPP W-CDMA	4 W to 300 W
Other signals at video bandwidth 4 kHz	0.4 W to 300 W
200 kHz	1 W to 300 W
4 MHz	2 W to 300 W

Measurement uncertainty  
18°C to 28°C

same as for average power plus effect of peak hold circuit

Error limits of peak hold circuit for burst signals

Duty cycle $\geq 0.1$ and repetition rate $\geq 100/s$	
video bandwidth 4 kHz	$\pm (3\% \text{ of measured value} + 0.05 \text{ W})$ starting from a burst width of 100 $\mu s$
200 kHz	$\pm (3\% \text{ of measured value} + 0.20 \text{ W})$ starting from a burst width of 4 $\mu s$
4 MHz	$\pm (7\% \text{ of measured value} + 0.40 \text{ W})$ starting from a burst width of 1 $\mu s$
20/s $\leq$ repetition rate $< 100/s$	plus $\pm (1.6\% \text{ of measured value} + 0.15 \text{ W})$
0.001 $\leq$ duty cycle $< 0.1$	plus $\pm 0.10 \text{ W}$
Burst width $\geq 0.5 \mu s$	plus $\pm 5\% \text{ of measured value}$
Burst width $\geq 0.2 \mu s$	plus $\pm 10\% \text{ of measured value}$

Range of typical measurement error of peak hold circuit for

cdmaOne, DAB	$\pm (5\% \text{ of measured value} + 0.4 \text{ W})$
DVB-T, cdma2000, 3GPP W-CDMA	$\pm (15\% \text{ of measured value} + 0.4 \text{ W})$
video bandwidth 4 MHz and standard selected on the R&S®FSH3-TV	

Temperature coefficient

200 MHz to 300 MHz	0.50 %/K (0.022 dB/K)
300 MHz to 4 GHz	0.35 %/K (0.015 dB/K)

Load matching

Matching measurement range

Return loss		
200 MHz to 3 GHz	0 to 23 dB	
3 GHz to 4 GHz	0 to 20 dB	
VSWR		
200 MHz to 3 GHz	$> 1.15$	
3 GHz to 4 GHz	$> 1.22$	

Minimum forward power, specs met from 0.2 W 0.03 W

Error limits for matching measurements

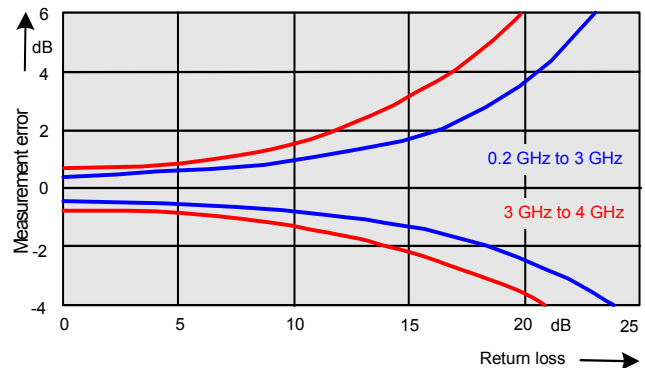

Power-handling capacity

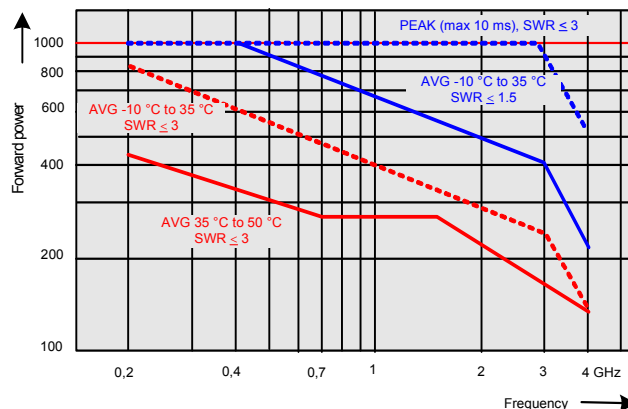

Dimensions

120 mm x 95 mm x 39 mm, connecting cable 1.5 m

Weight

0.65 kg

**VSWR Bridge and power divider R&S FSH-Z2**

Frequency range 10 MHz to 3 GHz

Impedance 50 Ω

**VSWR bridge**

Directivity, 10 MHz to 1 GHz 30 dB  
1 GHz to 3 GHz 25 dB

Directivity, corrected (option R&S FSH-K2)  
2 MHz to 10 MHz 40 dB  
10 MHz to 3 GHz 43 dB

Return loss at test port 20 dB

Return loss at test port, corrected (option R&S FSH-K2) 35 dB

Insertion loss 9 dB

**Power divider**

Return loss at test port 20 dB

**Connectors**

Generator input/RF output N male

Test port N female

Control interface 7-contact connector (type Binder)

**Calibration standards**

Short/open, 50 Ω load

Connector N male

Impedance 50 Ω

Return loss 46 dB

Power-handling capacity 1 W

**General data**

Power consumption 500 mW

Dimensions (W x H x D) 169 x 116 x 30 mm

Weight 485 g

**Distance-to-Fault Measurement (option R&S FSH-B1)**

Display	301 pixels
Maximum resolution, maximum zoom	cable length/1023 pixels
Display range	
Return loss	10, 5, 2, 1 dB/DIV, linear
VSWR	1-2 and 1-6, with option R&S®FSH-K2 in addition 1-1.2 and 1-1.5
Cable length, depending on cable loss	3 m to max. 1000 m
Maximum permissible spurious signal	3 m to max. 1000 m 1st mixer 1 dB compression point typ. +10 dBm IF overload at reference level typ. + 8 dB

**Reflection measurements (only with R&S FSH-Z2)**

Frequency range	10 MHz to 3 GHz
Display range of return loss	1, 10, 20, 50, 100 dB, selectable
VSWR display range	1-2 and 1-6, selectable, with option R&S®FSH-K2 also 1 to 1.2 and 1 to 1.5
Measurement uncertainty	see diagrams

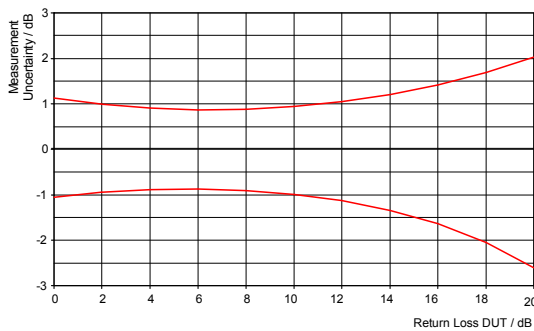

Measurement uncertainty with scalar measurements

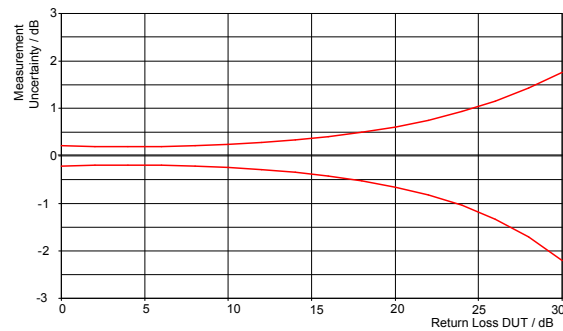

Measurement uncertainty with vector measurements (option R&S®FSH-K2)

**General data**

<b>Display</b>	14 cm (5.7") LC color display
Resolution	320 x 240 pixels
<b>Memory</b>	CMOS RAM
Settings and traces	100

**Environmental conditions**

**Temperature**

Operating temperature range	
R&S®FSH3-TV powered from internal battery	0°C to 50 °C
R&S®FSH3-TV powered from AC power supply	0°C to 40 °C
Storage temperature range	-20°C to +60 °C
Battery charging mode	0 °C to 40 °C

**Climatic conditions**

Relative humidity	95 % at 40 °C (IEC60068)
-------------------	--------------------------

**IP class of protection**

51



**Mechanical resistance**

Vibration, sinusoidal	complies with EN 60068-2-1, EN61010-1 5 Hz to 55 Hz: max. 2 g, 55 Hz to 150 Hz: 0.5 g constant, 12 minutes per axis
Vibration, random	complies with EN60068-2-64 10 Hz to 500 Hz, 1.9 g, 30 minutes per axis
Shock	complies with EN 60068-2-27 40 g shock spectrum

**RFI suppression**

complies with EMC directive of EU (89/336/EEC)  
and German EMC legislation

**Immunity to radiated interference**

10 V/m

Level display at 10 V/m (reference level  $\leq$  -10 dBm)

Input frequency	<-75 dBm (nominal)
IF	<-85 dBm (nominal)
Other frequencies	< displayed noise level

**Power Supply**

AC supply	plug-in AC power supply (R&S®FSH-Z33) 100 V AC to 240 V AC, 50 Hz to 60 Hz, 400 mA
External DC voltage	15 V to 20 V
Internal battery	NiMH battery
Operating time with fully charged battery	3 h to 4h depending on measurement mode
Battery charging time	4 h with instrument off
Lifetime	300 to 500 charging cycles
Power consumption in charging mode	12 W
Power consumption	7 W to 10 W depending on measurement mode
<b>Safety</b>	complies with EN 61010-1, UL 3111-1, CSA C22.2 No. 1010-1
Test mark	VDE, GS, CSA, CSA-NRTL
<b>Dimensions (W x H x D)</b>	170x120x270 mm
<b>Weight</b>	2.7 kg
<b>Accessories supplied</b>	external power supply, optical USB cable, headphones, Quick Start manual, CD-ROM with Control Software R&S®FSH View and documentation

**Options**

Designation	Type	Order No.
Remote Control for R&S FSH3-TV	R&S FSHTV-K1	2111.7140.02
DVB-C / J.83/A/B/C (QAM) Firmware for R&S FSH3-TV	R&S FSHTV-K21	2111.7211.02
ATSC/8-VSB Firmware for R&S FSH3-TV	R&S FSHTV-K22	2111.7228.02
Distance-to-Fault Measurement, includes 1 m cable, R&S <sup>®</sup> FSH-Z2 required	R&S FSH-B1	1145.5750.02
Vector Transmission and Reflection Measurements	R&S FSH-K2	1157.3387.02
Receiver Mode	R&S FSH-K3	1157.3429.02

**Optional accessories**

Preselector for R&S FSH3-TV	R&S FSHTV-Z60	2111.7105.02
Spare F adapter 75 $\Omega$ , female / female for Preselector R&S FSHTV-Z60	R&S FSHTV-Z61	2111.7111.02
Power Sensor 10 MHz to 8 GHz	R&S FSH-Z1	1155.4505.02
VSWR Bridge and Power Divider, 10 MHz to 3 GHz, contains Short, Open and 50 $\Omega$ Load for calibration	R&S FSH-Z2	1145.5767.02
Directional Power Sensor 25 MHz to 1 GHz	R&S FSH-Z14	1120.6001.02
Power Sensor 10 MHz to 18 GHz	R&S FSH-Z18	1165.1909.02
Directional Power Sensor 200 MHz to 4 GHz	R&S FSH-Z44	
Matching Pad 50/75 Ohm, 0 to 2700 MHz	R&S RAZ	0358.5714.02
Spare RFCable, 1m, N male / N female for option R&S FSH-B1	R&S FSH-Z20	1145.5867.02
12 V Car Adapter	R&S FSH-Z21	1145.5873.02
Serial/Parallel Converter	R&S FSH-Z22	1145.5880.02
Carrying Bag	R&S FSH-Z25	1145.5896.02
Transit Case	R&S FSH-Z26	1300.7627.02
Combined Short, Open and 50 $\Omega$ Load for VSWR and DTF calibration	R&S FSH-Z29	1300.7504.02
Spare Short / Open Calibration for R&S FSH-Z2	R&S FSH-Z30	1145.5773.02
Spare 50 $\Omega$ Load for option R&S FSH-Z2 for VSWR and DTF calibration	R&S FSH-Z31	1145.5780.02
Spare Battery Pack	R&S FSH-Z32	1145.5796.02
Spare AC Power Supply	R&S FSH-Z33	1145.5809.02
RS-232-C Optical Cable	R&S FSH-Z34	1145.5815.02
Spare Headphones	R&S FSH-Z36	1145.5838.02
Spare Optical USB Cable	R&S FSH-Z37	1300.7733.02
Matching Pad 50/75 Ohm, DC to 1000 MHz	R&S FSH-Z38	1300.7740.02
Spare CD-ROM with Control Software R&S FSH-View and Documentation for R&S FSH3-TV	R&S FSHTV-Z65	2111.7340.02

## Safety Instructions

This unit has been designed and tested in accordance with the EC Certificate of Conformity and has left the manufacturer's plant in a condition fully complying with safety standards.

To maintain this condition and to ensure safe operation, the user must observe all instructions and warnings given in this operating manual.

### Safety-related symbols used on equipment and documentation from R&S:



Observe operating instructions



PE terminal



Ground terminal



Danger!  
Shock hazard



Warning!  
Hot surfaces

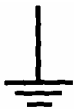

Ground



Attention!  
Electrostatic sensitive devices require special care

## Safety Instructions

1. The unit may be used only in the operating conditions and positions specified by the manufacturer. The R&S FSH3-TV is protected against dripping water and dust (IP degree 51). Unless otherwise agreed, the following applies : pollution severity 2, overvoltage category 2, altitude max. 2000 m powered from AC power supply, altitude max. 3000 m powered from battery.  
The unit may be operated only from supply networks fused with max. 16 A.  
Unless specified otherwise in the data sheet, a tolerance of  $\pm 10\%$  shall apply to the nominal voltage and of  $\pm 5\%$  to the nominal frequency.
2. For measurements in circuits with voltages  $V_{\text{rms}} > 30 \text{ V}$ , suitable measures should be taken to avoid any hazards (using, for example, appropriate measuring equipment, fusing, current limiting, electrical separation, insulation).
3. For permanently installed units without built-in fuses, circuit breakers or similar protective devices, the supply circuit must be fused such as to provide suitable protection for the users and equipment.
4. Prior to switching on the unit, it must be ensured that the nominal voltage set on the unit matches the nominal voltage of the AC supply network.  
If a different voltage is to be set, the power fuse of the unit may have to be changed accordingly.
5. If the unit has no power switch for disconnection from the AC supply, the plug of the connecting cable is regarded as the disconnecting device. In such cases it must be ensured that the power plug is easily reachable and accessible at all times (length of connecting cable approx. 2 m). Functional or electronic switches are not suitable for providing disconnection from the AC supply.  
If units without power switches are integrated in racks or systems, a disconnecting device must be provided at system level.
6. Applicable local or national safety regulations and rules for the prevention of accidents must be observed in all work performed.  
Prior to performing any work on the unit or opening the unit, the latter must be disconnected from the supply network.  
Any adjustments, replacements of parts, maintenance or repair may be carried out only by authorized R&S technical personnel.  
Only original parts may be used for replacing parts relevant to safety (eg power switches, power transformers, fuses). A safety test must be performed after each replacement of parts relevant to safety.  
(visual inspection, PE conductor test, insulation-resistance, leakage-current measurement, functional test).
7. Ensure that the connections with information technology equipment comply with IEC950 / EN60950.
8. NiMH batteries must not be exposed to high temperatures or fire.  
Keep batteries away from children.  
If the battery is replaced improperly, there is danger of explosion. Only replace the battery by R&S type (see spare part list).  
NiMH batteries are suitable for environmentally-friendly disposal or specialized recycling. Dispose them into appropriate containers, only.  
Do not short-circuit the battery.
9. Equipment returned or sent in for repair must be packed in the original packing or in packing with electrostatic and mechanical protection.
10. Electrostatics via the connectors may damage the equipment. For the safe handling and operation of the equipment, appropriate measures against electrostatics should be implemented.
11. The outside of the instrument is suitably cleaned using a soft, lint-free dustcloth. Never use solvents such as thinners, acetone and similar things, as they may damage the front panel labeling or plastic parts.
12. Any additional safety instructions given in this manual are also to be observed.

## **Certificate of quality**

Dear Customer,

You have decided to buy a Rohde & Schwarz product.

You are thus assured of receiving a product that is manufactured using the most modern methods available. This product was developed, manufactured and tested in compliance with our quality management system standards. The Rohde & Schwarz quality management system is certified according to ISO 9001.

Certified Quality System  
ISO 9001  
DQS REG. NO 1954-04



Certificate No.: 2005-24

This is to certify that:

Equipment type	Stock No.	Designation
FSH3-TV	2111.7005.63	TV Analyzer
FSHTV-Z60	2111.7105.02	Preselector

complies with the provisions of the Directive of the Council of the European Union on the approximation of the laws of the Member States

- relating to electrical equipment for use within defined voltage limits  
(73/23/EEC revised by 93/68/EEC)
- relating to electromagnetic compatibility  
(89/336/EEC revised by 91/263/EEC, 92/31/EEC, 93/68/EEC)

Conformity is proven by compliance with the following standards:

EN61010-1 : 2001  
EN55011 : 1998 + A1 : 1999 + A2 : 2002, Klasse B  
EN61326 : 1997 + A1 : 1998 + A2 : 2001

For the assessment of electromagnetic compatibility, the limits of radio interference for Class B equipment as well as the immunity to interference for operation in industry have been used as a basis.

Affixing the EC conformity mark as from 2005

**ROHDE & SCHWARZ GmbH & Co. KG**  
Mühldorfstr. 15, D-81671 München

Munich, 2005-06-08

Central Quality Management MF-QZ / Radde

## Support Center

Should you have any technical questions concerning this Rohde & Schwarz product, please contact the hotline of Rohde & Schwarz Vertriebs-GmbH, Support Center.

Our hotline team will answer your questions and find solutions to your problems.

You can reach the hotline Monday through Friday from 8:00 until 17:00 CET.

If you need assistance outside office hours, please leave a message or send us a fax or e-mail. We will contact you as soon as possible.



If you wish to receive the latest news about and updates for a specific instrument, please send us a short e-mail indicating the instrument. We will then send you up-to-date information on a regular basis.

Support Center:

Telephone: +49 180 512 42 42

Fax: + 49 89 41 29 - 137 77

e-mail: [CustomerSupport@rsd.rohde-schwarz.com](mailto:CustomerSupport@rsd.rohde-schwarz.com)

USA Customer Support Center:

Telephone: 1-888-837-8772 (1-888-Test-RSA)

E-mail: [info@rsa.rohde-schwarz.com](mailto:info@rsa.rohde-schwarz.com)

# Adressen/Addresses

## FIRMENSITZ/HEADQUARTERS

(Tel) Phone  
(Fax) Fax  
E-mail

Rohde & Schwarz GmbH & Co. KG  
Mühlendorfstraße 15 · D-81671 München  
Postfach 80 14 69 · D-81614 München

(Tel) +49 (89) 41 29-0  
(Fax) +49 89 4129-121 64  
info@rohde-schwarz.com

## WERKE/PLANTS

Rohde & Schwarz Messgerätebau GmbH  
Riedbachstraße 58 · D-87700 Memmingen  
Postfach 1652 · D-87686 Memmingen

(Tel) +49 (8331) 108-0  
(Fax) +49 (8331) 108-11 24  
info.rsdmb@rohde-schwarz.com

Rohde & Schwarz GmbH & Co. KG  
Werk Teisnach  
Kaikenrieder Straße 27 · D-94244 Teisnach  
Postfach 1149 · D-94240 Teisnach

(Tel) +49 (9923) 857-0  
(Fax) +49 (9923) 857-11 74  
info.rsdts@rohde-schwarz.com

Rohde & Schwarz GmbH & Co. KG  
Dienstleistungszentrum Köln  
Graf-Zeppelin-Straße 18 · D-51147 Köln  
Postfach 98 02 60 · D-51130 Köln

(Tel) +49 (2203) 49-0  
(Fax) +49 (2203) 49 51-229  
info.rsd@rohde-schwarz.com  
schwarz.com-service.rsd@rohde-schwarz.com

## TOCHTERUNTERNEHMEN/SUBSIDIARIES

Rohde & Schwarz Vertriebs-GmbH  
Mühlendorfstraße 15 · D-81671 München  
Postfach 80 14 69 · D-81614 München

(Tel) +49 (89) 41 29-137 74  
(Fax) +49 (89) 41 29-137 77  
customersupport@rohde-schwarz.com

Rohde & Schwarz International GmbH  
Mühlendorfstraße 15 · D-81671 München  
Postfach 80 14 60 · D-81614 München

(Tel) +49 (89) 41 29-129 84  
(Fax) +49 (89) 41 29-120 50  
info.rusis@rohde-schwarz.com

Rohde & Schwarz Engineering and Sales GmbH  
Mühlendorfstraße 15 · D-81671 München  
Postfach 80 14 29 · D-81614 München

(Tel) +49 (89) 41 29-137 11  
(Fax) +49 (89) 41 29-137 23  
info.rse@rohde-schwarz.com

R&S BICK Mobilfunk GmbH  
Fritz-Hahne-Str. 7 · D-31848 Bad Münder  
Postfach 2062 · D-31844 Bad Münder

(Tel) +49 (5042) 998-0  
(Fax) +49 (5042) 998-105  
info.rsbeck@rohde-schwarz.com

Rohde & Schwarz FTK GmbH  
Wendenschlossstraße 168, Haus 28  
D-12557 Berlin

(Tel) +49 (30) 658 91-122  
(Fax) +49 (30) 655 50-221  
info.ftk@rohde-schwarz.com

Rohde & Schwarz SIT GmbH  
Agastraße 3  
D-12489 Berlin

(Tel) +49 (30) 658 84-0  
(Fax) +49 (30) 658 84-183  
info.sit@rohde-schwarz.com

R&S Systems GmbH  
Graf-Zeppelin-Straße 18 · D-51147 Köln  
Postfach 98 02 60 · D-51130 Köln

(Tel) +49 (2203) 49-5 23 25  
(Fax) +49 (2203) 49-5 23 36  
info.rssys@rohde-schwarz.com

## ADRESSEN WELTWEIT/ADDRESSES WORLDWIDE

**Albania** siehe/see Austria

**Algeria** Rohde & Schwarz  
Bureau d'Alger  
5B Place de Laperrine  
16035 Hydra-Alger

(Tel) +213 (21) 48 20 18  
(Fax) +213 (21) 69 46 08

**Antilles (Neth.)** siehe / see Mexico

**Argentina** Precision Electronica S.R.L.  
Av. Pde Julio A. Roca 710 - 6° Piso  
1067 Buenos Aires

(Tel) +541 (14) 331 10 67  
(Fax) +541 (14) 334 51 11  
alberto.lombardi@prec-elec.com.ar

**Australia** Rohde & Schwarz (Australia) Pty. Ltd.  
Sales Support  
Unit 6  
2-8 South Street  
Rydalmere, N.S.W. 2116

(Tel) +61 (2) 88 45 41 00  
(Fax) +61 (2) 96 38 39 88  
sales@rsa.us.rohde-schwarz.com

**Austria** Rohde & Schwarz-Österreich Ges.m.b.H.  
Am Europlatz 3  
Gebäude B  
1120 Wien

(Tel) +43 (1) 602 61 41-0  
(Fax) +43 (1) 602 61 41-14  
rs-austria@rsoe.rohde-schwarz.com

**Azerbaijan** Rohde & Schwarz Azerbaijan  
Liaison Office Baku  
ISR Plaza, 5th floor  
340 Nizami Str.  
370000 Baku

(Tel) +994 (12) 93 31 38  
(Fax) +994 (12) 93 03 14  
rs-azerbaijan@rsd.rohde-schwarz.com

**Bangladesh** BIL Consortium Ltd.  
Corporate Office  
House-33, Road-4, Block-F  
Banani, Dhaka-1213

(Tel) +880 (2) 881 06 53  
(Fax) +880 (2) 882 82 91

**Barbados** siehe / see Mexico

**Belarus** siehe/see Ukraine

**Belgium** Rohde & Schwarz Belgium N.V.  
Excelsiorlaan 31 Bus 1  
1930 Zaventem

(Tel) +32 (2) 721 50 02  
(Fax) +32 (2) 725 09 36  
info@rsb.rohde-schwarz.com

**Belize** siehe / see Mexico

**Bermuda** siehe/see Mexico

**Bosnia-Herzegovina** siehe/see Slovenia

**Brazil** Rohde & Schwarz Do Brasil Ltda.  
Av. Alfredo Egidio de Souza Aranha (Bd. Aranha)  
1° andar - Santo Amaro  
04726-170 Sao Paulo - SP

(Tel) +55 (11) 56 44 86 11  
(Fax) +55 (11) 56 44 86 25 (sales)  
(Fax) +55 (11) 56 44 86 36  
sales-brazil@rsdb.rohde-schwarz.com

**Brunei** George Keen Lee Equipment Pte Ltd.  
#11-01 BP Tower  
396 Alexandra Road  
Singapore 119954

(Tel) +656 276 06 26  
(Fax) +656 276 06 29  
gkleqpt@singnet.com.sg

**Bulgaria** Rohde & Schwarz  
Representation Office Bulgaria  
39, Fridtjof Nansen Blvd.  
1000 Sofia

(Tel) +359 (2) 96 343 34  
(Fax) +359 (2) 963 21 97  
rs-bulgaria@rsbg.rohde-schwarz

**Canada** Rohde & Schwarz Canada Inc.  
555 March Rd.  
Kanata, Ontario K2K 2M5

(Tel) +1 (613) 592 80 00  
(Fax) +1 (613) 592 80 09  
sales@rscanada.ca

**Chile** Dymeq Ltda.  
Av. Larrain 6666  
Santiago

(Tel) +56 (2) 339 20 00  
(Fax) +56 (2) 339 20 10  
dymeq@dymeq.com

**China** Rohde & Schwarz China Ltd.  
Representative Office Beijing  
6F, Parkview Center  
2 Jiangtai Road  
Chao Yang District  
Beijing 100016

(Tel) +86 (10) 64 31 28 28  
(Fax) +86 (10) 64 37 98 88  
info.rschina@rsbp.rohde-schwarz.com

Rohde & Schwarz China Ltd.  
Representative Office Shanghai  
Room 807-809, Central Plaza  
227 Huangpi North Road  
Shanghai 200003

(Tel) +86 (21) 63 75 00 18  
(Fax) +86 (21) 63 75 91 70  
May.Zhu@rsbp.rohde-schwarz.com

Rohde & Schwarz China Ltd.  
Representative Office Guangzhou  
Room 2903, Metro Plaza  
183 Tian He North Road  
Guangzhou 510075

(Tel) +86 (20) 87 55 47 58  
(Fax) +86 (20) 87 55 47 59  
Winnie.Lin@rsbp.rohde-schwarz.com



# Adressen/Addresses

<b>China</b>	Rohde & Schwarz China Ltd. Representative Office Chengdu Unit G, 28/F, First City Plaza 308 Shuncheng Avenue Chengdu 610017	(Tel) +86 (28) 86 52 76 06 (Fax) +86 (28) 86 52 76 10 sophia.chen@rsbp.rohde-schwarz.com	<b>Germany</b>	Zweigniederlassung Büro Bonn Josef-Wirmer-Straße 1-3 · D-53123 Bonn Postfach 140264 · D-53057 Bonn	(Tel) +49 (228) 918 90-0 (Fax) +49 (228) 25 50 87 info.rsv@rohde-schwarz.com	
	Rohde & Schwarz China Ltd. Representative Office Xian Room 603, Jin Xin International No. 99 Heping Road Xian 710001	(Tel) +86 (29) 87 41 53 77 (Fax) +86 (29) 87 20 65 00 sherry.yu@rsbp.rohde-schwarz.com		Zweigniederlassung Nord, Geschäftsstelle Hamburg Vierenkamp 6 D-22423 Hamburg	(Tel) +49 (40) 38 61 83 - 00 (Fax) +49 (40) 38 61 83 - 20 info.rsv@rohde-schwarz.com	
	Rohde & Schwarz China Ltd. Representative Office Shenzhen Room 1901, Central Business Building No. 88 Fuhua Yilu Futian District Shenzhen 518026	(Tel) +86 (755) 82 03 11 98 (Fax) +86 (755) 82 03 30 70 jessica.lia@rsbp.rohde-schwarz.com		Zweigniederlassung Mitte, Geschäftsstelle Köln Niederlasser Straße 33 · D-51147 Köln Postfach 900 149 · D-51111 Köln	(Tel) +49 (2203) 807-0 (Fax) +49 (2203) 807-650 info.rsv@rohde-schwarz.com	
<b>Costa Rica</b>	siehe / see Mexico			Zweigniederlassung Süd, Geschäftsstelle München Mühlhildstraße 15 · D-81671 München Postfach 80 14 69 · D-81614 München	(Tel) +49 (89) 41 86 95-0 (Fax) +49 (89) 40 47 64 info.rsv@rohde-schwarz.com	
<b>Croatia</b>	siehe/see Slovenia			Zweigniederlassung Süd, Geschäftsstelle Nürnberg Donaustraße 36 D-90451 Nürnberg	(Tel) +49 (911) 642 03-0 (Fax) +49 (911) 642 03-33 info.rsv@rohde-schwarz.com	
<b>Cuba</b>	siehe / see Mexico			Zweigniederlassung Mitte, Geschäftsstelle Neu-Isenburg Siemensstraße 20 D-63263 Neu-Isenburg Postfach 16 51 D-63236 Neu-Isenburg	(Tel) +49 (6102) 20 07-0 (Fax) +49 (6102) 20 07 12 info.rsv@rohde-schwarz.com	
<b>Cyprus</b>	Hinis Telecast Ltd. Agiou Thoma 18 Kiti Larnaca 7550	(Tel) +357 (24) 42 51 78 (Fax) +357 (24) 42 46 21 hinis@logos.cy.net		<b>Ghana</b>	Kop Engineering Ltd. P.O. Box 11012 3rd Floor Akai House, Osu Accra North	(Tel) +233 (21) 77 89 13 (Fax) +233 (21) 701 06 20 joblink@ghana.com
<b>Czech Republic</b>	Rohde & Schwarz Praha, s.r.o. Hadovka Office Park Evropská 2590/33c 16000 Praha 6	(Tel) +420 (2) 24 31 12 32 (Fax) +420 (2) 24 31 70 43 office@rscz.rohde-schwarz.com		<b>Greece</b>	Mercury S.A. 6, Loukianou Str. 10675 Athens	(Tel) +302 (10) 722 92 13 (Fax) +302 (10) 721 51 98 mercury@hol.gr
<b>Denmark</b>	Rohde & Schwarz Danmark A/S Ejby Industrivej 40 2600 Glostrup	(Tel) +45 (43) 43 66 99 (Fax) +45 (43) 43 77 44 rsdk@rsdk.rohde-schwarz.com		<b>Guatemala</b>	siehe/see Mexico	
<b>Egypt</b>	U.A.S. Universal Advanced Systems 31 Manshiet El-Bakry Street Heliopolis 11341 Cairo	(Tel) +20 (2) 455 67 44 (Fax) +20 (2) 256 17 40 an_uas@link.net		<b>Guiana</b>	siehe / see Mexico	
<b>El Salvador</b>	siehe/see Mexico			<b>Haiti</b>	siehe / see Mexico	
<b>Estonia</b>	Rohde & Schwarz Danmark A/S Estonian Branch Office Narva mnt. 13 10151 Tallinn	(Tel) +372 (6) 14 31 23 (Fax) +372 (6) 14 31 21 estonia@rsdk.rohde-schwarz.com		<b>Honduras</b>	siehe/see Mexico	
<b>Finland</b>	Rohde & Schwarz Finland Oy Taivaltie 5 01610 Vantaa	(Tel) +358 (207) 60 04 00 (Fax) +358 (207) 60 04 17 info@rsfin.rohde-schwarz.com		<b>Hong Kong</b>	Electronic Scientific Engineering 9/F North Somerset House Taikoo Place 979 King's Road, Quarry Bay Hong Kong	(Tel) +852 (25) 07 03 33 (Fax) +852 (25) 07 09 25 stephenchau@ese.com.hk
<b>France</b>	Rohde & Schwarz France Immeuble "Le Newton" 9-11, rue Jeanne Braconnier 92366 Meudon La Forêt Cédex	(Tel) +33 (0) 141 36 10 00 (Fax) +33 (0) 141 36 11 11 contact@rsf.rohde-schwarz.com		<b>Hungary</b>	Rohde & Schwarz Budapesti Iroda Váci út 169 1138 Budapest	(Tel) +36 (1) 412 44 60 (Fax) +36 (1) 412 44 61 rs-hungary@rshu.rohde-schwarz.com
	Niederlassung/Subsidiary Rennes 37 Rue du Bignon Bâtiment A 35510 Cesson Sévigné	(Tel) +33 (2) 99 51 97 00 (Fax) +33 (2) 99 51 98 77		<b>Iceland</b>	siehe/see Denmark	
<b>Germany</b>	Zweigniederlassungen der Rohde & Schwarz Vertriebs-GmbH/Branch offices of Rohde & Schwarz Vertriebs-GmbH			<b>India</b>	Rohde & Schwarz India Pvt. Ltd. 244, Okhla Industrial Estate Phase - III New Delhi 110 020	(Tel) +91 (11) 26 32 63 81 (Fax) +91 (11) 26 32 63 73 sales@rsindia.rohde-schwarz.com
	Zweigniederlassung Nord, Geschäftsstelle Berlin Ernst-Reuter-Platz 10 · D-10587 Berlin Postfach 100620 · D-10566 Berlin	(Tel) +49 (30) 34 79 48-0 (Fax) +49 (30) 34 79 48 48 info.rsv@rohde-schwarz.com			Rohde & Schwarz India Pvt. Ltd. Bangalore Office No. 24, Service Road, Domlur 2nd Stage Extension Bangalore - 560 071	(Tel) +91 (80) 535 23 62 (Fax) +91 (80) 535 03 61 rsindiab@rsnl.net
					Rohde & Schwarz India Pvt. Ltd. Hyderabad Office 302 & 303, Millennium Centre 6-3-1099/1100, Somajiguda Hyderabad - 500 016	(Tel) +91 (40) 23 32 24 16 (Fax) +91 (40) 23 32 27 32 rsindiah@nd2.dot.net.in

# Adressen/Addresses

<b>India</b>	Rohde & Schwarz India Pvt. Ltd. Mumbai Office B-603, Remi Bizcourt, Shah Industrial Estate, Off Veera Desai Road Andheri West Mumbai - 400 058	(Tel) +91 (22) 26 30 18 10 (Fax) +91 (22) 26 73 20 81 rsindiam@rsnl.net	<b>Kazakhstan</b>	Rohde & Schwarz Kazakhstan Representative Office Almaty Pl. Respubliki 15 480013 Almaty	(Tel) +7 (32) 72 67 23 54 (Fax) +7 (32) 72 67 23 46 rs-kazakhstan@rsd-rohde-schwarz.com
<b>Indonesia</b>	PT Rohde & Schwarz Indonesia Graha Paramita 5th Floor Jln. Denpasar Raya Blok D-2 Jakarta 12940	(Tel) +62 (21) 252 36 08 (Fax) +62 (21) 252 36 07 sales@rsbj.rohde-schwarz.com-services@rsbj.rohde-schwarz.com	<b>Kenya</b>	Excel Enterprises Ltd Dunga Road P.O.Box 42 788 Nairobi	(Tel) +254 (2) 55 80 88 (Fax) +254 (2) 54 46 79
<b>Iran</b>	Rohde & Schwarz Iran Liaison Office Tehran Groundfloor No. 1, 14th Street Khaled Eslamboli (Vozara) Ave. 15117 Tehran	(Tel) +98 (21) 872 42 96 (Fax) +98 (21) 871 90 12 alfred.korff@rsd.rohde-schwarz.com	<b>Korea</b>	Rohde & Schwarz Korea Ltd. 83-29 Nonhyun-Dong, Kangnam-Ku  Seoul 135-010	(Tel) +82 (2) 34 85 19 00 (Fax) +82 (2) 547 43 00 sales@rskor.rohde-schwarz.com-service@rskor.rohde-schwarz.com
<b>Ireland</b>	siehe/see United Kingdom		<b>Kuwait</b>	Group Five Trading & Contracting Co. Mezzanine Floor Al-Bana Towers Ahmad Al Jaber Street Sharq	(Tel) +965 (244) 91 72/73/74 (Fax) +965 (244) 95 28 jk_agarwal@yahoo.com
<b>Israel</b>	Eastronics Ltd. Measurement Products 11 Rozanis St. P.O.Box 39300 Tel Aviv 61392	(Tel) +972 (3) 645 87 77 (Fax) +972 (3) 645 86 66 david_hasky@easx.co.il	<b>Latvia</b>	Rohde & Schwarz Danmark A/S Latvian Branch Office Merkela iela 21-301 1050 Riga	(Tel) +371 (7) 50 23 55 (Fax) +371 (7) 50 23 60 latvia@rsdk.rohde-schwarz.com
	J.M. Moss (Engineering) Ltd. Communications Products 9 Oded Street P.O.Box 967 52109 Ramat Gan	(Tel) +972 (3) 631 20 57 (Fax) +972 (3) 631 40 58 jmoss@zahav.net.il	<b>Lebanon</b>	Rohde & Schwarz Liaison Office Riyadh P.O.Box 361 Riyadh 11411	(Tel) +966 (1) 465 64 28 Ext. 303 (Fax) +966 (1) 465 64 28 Ext. 229 chris.porzky@rsd.rohde-schwarz.com
<b>Italy</b>	Rohde & Schwarz Italia S.p.a. Centro Direzionale Lombardo Via Roma 108 20060 Cassina de Pecchi (MI)	(Tel) +39 (02) 95 70 41 (Fax) +39 (02) 95 30 27 72 rsi.info@rsi.rohde-schwarz.com		Netcom P.O.Box 55199 Op. Ex-Presidential Palace Horch Tabet Beirut	(Tel) +961 (1) 48 69 99 (Fax) +961 (1) 49 05 11 tohme.sayar@netcomm.tv
	Rohde & Schwarz Italia S.p.a. Via Tiburtina 1182 00156 Roma	(Tel) +39 (06) 41 59 81 (Fax) +39 (06) 41 59 82 70 rsi.info@rsi.rohde-schwarz.com	<b>Liechtenstein</b>	siehe/see Switzerland	
<b>Jamaica</b>	siehe / see Mexico		<b>Lithuania</b>	Rohde & Schwarz Danmark A/S Lithuanian Branch Office Lukiskiu 5-228 2600 Vilnius	(Tel) +370 (5) 239 50 10 (Fax) +370 (5) 239 50 11 lithuania@rsdk.rohde-schwarz.com
<b>Japan</b>	Rohde & Schwarz Japan K.K. Tokyo Office 711 Bldg., Room 501 (5th floor) 7-11-18 Nishi-Shinjuku Shinjuku-ku Tokyo 160-0023	(Tel) +81 (3) 59 25 12 88 (Fax) +81 (3) 59 25 12 90 scj.support@rsjp.rohde-schwarz.com	<b>Luxembourg</b>	siehe/see Belgium	
	Rohde & Schwarz Japan K.K. Shin-Yokohama Office KM Daiichi Bldg., 8F 2-13-13 Kouhoku-ku Yokohama-shi Kanagawa 222-0033	(Tel) +81 (4) 54 77 35 70	<b>Macedonia</b>	NETRA Sarski odred 7 1000 Skopje	(Tel) +389 (2) 329 82 30 (Fax) +389 (2) 317 74 88 netra@netra.com.sk
	Rohde & Schwarz Japan K.K. Osaka Office TEK Dai 2 Bldg., 8F 1-13-20 Esaka-shi Suita-shi Osaka-fu 564-0063	(Tel) +81 (6) 63 10 96 51	<b>Malaysia</b>	Rohde & Schwarz Malaysia Sdn Bhd Suite 10.04, Level 10, Wisma E&C No. 2 Lorong Dungun Kiri Damansara Heights 50490 Kuala-Lumpur	(Tel) +60 (3) 20 94 00 33 (Fax) +60 (3) 20 94 24 33 sales.malaysia@rohde-schwarz.com
<b>Jordan</b>	Jordan Crown Engineering & Trading Co. Jabal Amman, Second Circle Youssef Ezzideen Street P.O.Box 830414 Amman, 11183	(Tel) +962 (6) 462 17 29 (Fax) +962 (6) 465 96 72 jocrown@go.com.jo	<b>Malta</b>	Tektraco International Technology Ltd. 121, B'Kara Road San Gwann SGN 08	(Tel) +356 (21) 37 43 00 or 37 80 88 (Fax) +356 (21) 37 66 67 sales@tektraco.com
			<b>Mexico</b>	Rohde & Schwarz de Mexico S. de R.L. de C.V. German Centre Oficina 4-2-2 Av. Santa Fé 170 Col. Lomas de Santa Fé 01210 Mexico D.F.	(Tel) +52 (55) 85 03 99 13 (Fax) +52 (55) 85 03 99 16 latinoamerica@rsd-rohde-schwarz.com
			<b>Moldava</b>	siehe/see Austria	
			<b>Nepal</b>	ICTC Pvt. Ltd. Hattisar, Post Box No. 660 Kathmandu	(Tel) +977 (1) 443 48 95 (Fax) +977 (1) 443 49 37 ictc@mos.com.np

# Adressen/Addresses

<b>Netherlands</b>	Rohde & Schwarz Nederland B.V. Perkinsbaan 1 3439 ND Nieuwegein	(Tel) +31 (30) 600 17 00 (Fax) +31 (30) 600 17 99 info@rsn.rohde-schwarz.com	<b>Saudi Arabia</b>	Gentec Haji Abdullah Alireza & Co. Ltd. P.O.Box 43054 Riyadh	(Tel) +966 (1) 293 20 35 (Fax) +966 (1) 466 16 57 akanbar@gentec.com.sa
<b>New Zealand</b>	Nichecom 1 Lincoln Ave. Tawa, Wellington	(Tel) +64 (4) 232 32 33 (Fax) +64 (4) 232 32 30 rob@nichecom.co.nz	<b>Serbia-Montenegro</b>	Rohde & Schwarz Representative Office Belgrade Tose Jovanovica 7 11030 Beograd	(Tel) +381 (11) 305 50 25 (Fax) +381 (11) 305 50 24 rs-scg@rscs.rohde-schwarz.com
<b>Nicaragua</b>	siehe/see Mexico		<b>Singapore</b>	Rohde & Schwarz Regional Headquarters Singapore Pte. Ltd. 1 Kaki Bukit View #05-01/02 Techview Singapore 415 941	(Tel) +65 68 46 18 72 (Fax) +65 68 46 12 52
<b>Nigeria</b>	Ferrostaal Abuja Plot 3323, Barada Close P.O.Box 8513, Wuse Off Amazon Street Maitama, Abuja	(Tel) +234 (9) 413 52 51 (Fax) +234 (9) 413 52 50 fsabuja@rosecom.net			
<b>Norway</b>	Rohde & Schwarz Norge AS Enebakkeveien 302 B 1188 Oslo	(Tel) +47 (23) 38 66 00 (Fax) +47 (23) 38 66 01 firmapost@rsnor.rohde-schwarz.com		Rohde & Schwarz Systems & Communications Asia Pte Ltd Service 1 Kaki Bukit View #04-01/07 Techview Singapore 415 941	(Tel) +65 68 46 37 10 (Fax) +65 68 46 00 29 info@rssg.rohde-schwarz.com
<b>Oman</b>	Mustafa Sultan Science & Industry Co.LLC. Test & Measurement Products Way No. 3503 Building No. 241 Postal Code 112 Al Khuwair, Muscat	(Tel) +968 63 60 00 (Fax) +968 60 70 66 m-aziz@mustafasultan.com	<b>Slovak Republic</b>	Specialne systémy a software, a.s. Svrčia ul. 3 841 04 Bratislava 4	(Tel) +421 (2) 65 42 24 88 (Fax) +421 (2) 65 42 07 68 3s@special.sk
<b>Pakistan</b>	Siemens Pakistan 23, West Jinnah Avenue Islamabad	(Tel) +92 (51) 227 22 00 (Fax) +92 (51) 227 54 98 reza.bokhary@siemens.com.pk	<b>Slovenia</b>	Rohde & Schwarz Representative Office Ljubljana Tbilisjska 89 1000 Ljubljana	(Tel) +386 (1) 423 46 51 (Fax) +386 (1) 423 46 11 rs-slovenia@rssi.rohde-schwarz.com
<b>Panama</b>	siehe/see Mexico		<b>South Africa</b>	Protea Data Systems (Pty.) Ltd. Communications and Measurement Division Private Bag X19 Bramley 2018	(Tel) +27 (11) 719 57 00 (Fax) +27 (11) 786 58 91 unicm@protea.co.za
<b>Papua New Guinea</b>	siehe/see Australia				
<b>Paraguay</b>	siehe/see Argentina				
<b>Philippines</b>	Rohde & Schwarz (Philippines) Inc. Unit 2301, PBCOM Tower 6795, Ayala Ave. cor. Herrera St. Makati City	(Tel) +63 (2) 753 14 44 (Fax) +63 (2) 753 14 56		Protea Data Systems (Pty.) Ltd. Cape Town Branch Unit G9, Centurion Business Park Bosmandam Road Milnerton Cape Town, 7441	(Tel) +27 (21) 555 36 32 (Fax) +27 (21) 555 42 67 unicm@protea.co.za
<b>Poland</b>	Rohde & Schwarz SP.z o.o. Przedstawicielstwo w Polsce ul. Stawki 2, Pietro 28 00-193 Warszawa	(Tel) +48 (22) 860 64 94 (Fax) +48 (22) 860 64 99 rs-poland@rspl.rohde-schwarz.com	<b>Spain</b>	Rohde & Schwarz Espana S.A. Salcedo, 11 28034 Madrid	(Tel) +34 (91) 334 10 70 (Fax) +34 (91) 729 05 06 rses@rses.rohde-schwarz.com
<b>Portugal</b>	Rohde & Schwarz Portugal, Lda. Alameda Antonio Sergio 7-R/C - Sala A 2795-023 Linda-a-Velha	(Tel) +351 (21) 415 57 00 (Fax) +351 (21) 415 57 10 info@rspt.rohde-schwarz.com		Rohde & Schwarz Espana S.A. Av. Príncipe d'Astúries, 66 08012 Barcelona	(Tel) +34 (93) 415 15 68 (Fax) +34 (93) 237 49 95 bcn@rses.rohde-schwarz.com
<b>Republic Dominican</b>	siehe/see Mexico		<b>Sri Lanka</b>	Dynatel Communications (PTE) Ltd. 451/A Kandy Road Kelaniya	(Tel) +94 (112) 90 80 01 (Fax) +94 (112) 91 04 69 69 dynatel@dyanet.lk
<b>Romania</b>	Rohde & Schwarz Representation Office Bucharest 89 Eroii Sanitari Blvd., sector 5 050472 Bucuresti	(Tel) +40 (21) 411 20 13 (Fax) +40 (21) 410 68 46 rs-romania@rsro.rohde-schwarz.com	<b>Sudan</b>	SolarMan Co. Ltd. P.O.Box 11 545 North of Fraouq Cementry 6/7/9 Bldg. 16 Karthoum	(Tel) +249 (183) 47 31 08 (Fax) +249 (183) 47 31 38 solarman29@hotmail.com
<b>Russian Federation</b>	Rohde & Schwarz International GmbH 119180, Yakimanskaya nab., 2 Moscow	(Tel) +7 (095) 745 88 50 to 53 (Fax) +7 (095) 745 88 54 rs-russia@rsru.rohde-schwarz.com	<b>Sweden</b>	Rohde & Schwarz Sverige AB Flygfältsgatan 15 128 30 Skarpnäck	(Tel) +46 (8) 605 19 00 (Fax) +46 (8) 605 19 80 info@rss.rohde-schwarz.com
<b>Saudi Arabia</b>	Rohde & Schwarz International GmbH - Liaison Office Riyadh c/o Haji Abdullah Alireza Co. Ltd. P.O.Box 361 Riyadh 11411	(Tel) +966 (1) 293 2035 (Fax) +966 (1) 466 1657 chris.porzky@rsd.rohde-schwarz.com	<b>Switzerland</b>	Roschi Rohde & Schwarz AG Mühlestr. 7 3063 Ittigen	(Tel) +41 (31) 922 15 22 (Fax) +41 (31) 921 81 01 support@roschi.rohde-schwarz.com
			<b>Syria</b>	Electro Scientific Office Baghdad Street Dawara Clinical Lab. Bldg P.O.Box 8162 Damascus	(Tel) +963 (11) 231 59 74 (Fax) +963 (11) 231 88 75 memo@hamshointl.com

# Adressen/Addresses

<b>Taiwan</b>	Rohde & Schwarz Taiwan (Pvt.) Ltd. Floor 14, No. 13, Sec. 2, Pei-Tou Road Taipei 112	(Tel) +886 (2) 28 93 10 88 (Fax) +886 (2) 28 91 72 60 celine.tu@rstw.rohde-schwarz.com	<b>United Kingdom</b>	Rohde & Schwarz UK Ltd. 3000 Manchester Business Park Aviator Way Manchester M22 5TG	(Tel) +44 (870) 735 16 42 (Fax) +44 (1252) 81 14 77 sales@rsuk.rohde-schwarz.com
<b>Tanzania</b>	SSTL Group P.O. Box 7512 Dunga Street Plot 343/345 Dar Es Salaam	(Tel) +255 (22) 276 00 37 (Fax) +255 (22) 276 02 93 sstl@ud.co.tz	<b>Uruguay</b>	Aeromarine S.A. Cerro Largo 1497 11200 Montevideo	(Tel) +598 (2) 400 39 62 (Fax) +598 (2) 401 85 97 cs@aeromarine.com.uy
<b>Thailand</b>	Rohde & Schwarz International Thailand 2nd floor Gems Tower Bangrak, Suriyawong Bangkok 10600	(Tel) +66 (2) 200 07 29 (Fax) +66 (2) 267 00 79	<b>USA</b>	Rohde & Schwarz, Inc. Eastern Regional Office (US Headquarters) 8661A Robert Fulton Drive Columbia, MD 21046-2265	(Tel) +1 (410) 910 78 00 (Fax) +1 (410) 910 78 01 info@rsa.rohde-schwarz.com
	Schmidt Electronics (Thailand) Ltd. Messtechnik 202 Le Concorede Tower, 23rd Fl. Ratchadaphisek Rd. Huay kwang Bangkok 10320	(Tel) +66 (2) 69 41 47 05 (Fax) +66 (2) 69 41 47 06 salestm@schmidtelectronics.com		Rohde & Schwarz, Inc. Central Regional Office / Systems & EMI Products 8080 Tristar Drive Suite 120 Irving, TX 75063	(Tel) +1 (469) 713 53 00 (Fax) +1 (469) 713 53 01 info@rsa.rohde-schwarz.com
	TPP Operation Co. Ltd. Kommunikationstechnik 41/5 Mooban Tarinee Boromrajchonnee Road Talingchan Bangkok 10170	(Tel) +66 (2) 880 93 47 (Fax) +66 (2) 880 93 47		Rohde & Schwarz, Inc. R&D and Application Support 8905 SW Nimbus Ave Suite 240 Beaverton, OR 97008	(Tel) +1 (503) 403 47 00 (Fax) +1 (503) 403 47 01 info@rsa.rohde-schwarz.com
<b>Trinidad &amp; Tobago</b>	siehe/see Mexico	(Tel) (Fax)		Rohde & Schwarz, Inc. Western Regional Office 7700 Irvine Center Drive Suite 100 Irvine, CA 92618	(Tel) +1 (949) 885 70 00 (Fax) +1 (949) 885 70 01 info@rsa.rohde-schwarz.com
<b>Tunisia</b>	Teletek 71, Rue Alain Savary Residence Alain Savary (C64) Cit� el Khadra 1003 Tunis	(Tel) +216 (71) 77 33 88 (Fax) +216 (71) 77 05 53 teletek@gnet.tn		Rohde & Schwarz, Inc. Service & Calibration Center 8661A Robert Fulton Drive Columbia, MD 21046-2265	(Tel) +1 (410) 910 50 02 (Fax) +1 (410) 910 79 31 service.rsa@rsa.rohde-schwarz.com
<b>Turkey</b>	Rohde & Schwarz International GmbH Liaison Office Istanbul Bagdat Cad. 191/3, Arda Apt. B-Blok 81030 Selamicesme-Istanbul	(Tel) +90 (216) 385 19 17 (Fax) +90 (216) 385 19 18 nadir.guerelman@rsd.rohde-schwarz.com	<b>Vietnam</b>	Rohde & Schwarz Representative Office Vietnam Unit 807, 8/F, Schmidt Tower 239 Xuan Thuy Road Cau Giay District Hanoi	(Tel) +84 (4) 834 20 46
<b>Ukraine</b>	Rohde & Schwarz Representative Office Kiev 4, Patris Loumoumba ul. 01042 Kiev	(Tel) +38 (044) 268 60 55 (Fax) +38 (044) 268 83 64 rsbkiev@public.ua.net	<b>West Indies</b>	siehe/see Mexico	
<b>United Arab Emirates</b>	Rohde & Schwarz International GmbH Liaison Office Middle East Vertrieb P.O. Box 31156 Abu Dhabi	(Tel) +971 (2) 6335 670 (Fax) +971 (2) 6335 671 Dario Barisoni@rsd.rohde-schwarz.com			
	Rohde & Schwarz Bick Mobile Communication P.O.Box 17466 JAFZ, PPU ZG-07 Dubai	(Tel) +971 (4) 883 71 35 (Fax) +971 (4) 883 71 36			
	Rohde & Schwarz Emirates L.L.C. ESNAAD Premisses at Mussafah, P.O.Box 31156 Abu Dhabi	(Tel) +971 (2) 55 49 411 (Fax) +971 (2) 55 49 433 rsuaeam@emirates.net.ae			
<b>United Kingdom</b>	Rohde & Schwarz UK Ltd. Ancells Business Park Fleet Hampshire GU51 2UZ	(Tel) +44 (1252) 81 88 88 (sales)+44 (1252) 81 88 18 (service) (Fax) +44 (1252) 81 14 47 sales@rsuk.rohde-schwarz.com			

# 1 Putting into Operation

## Front view

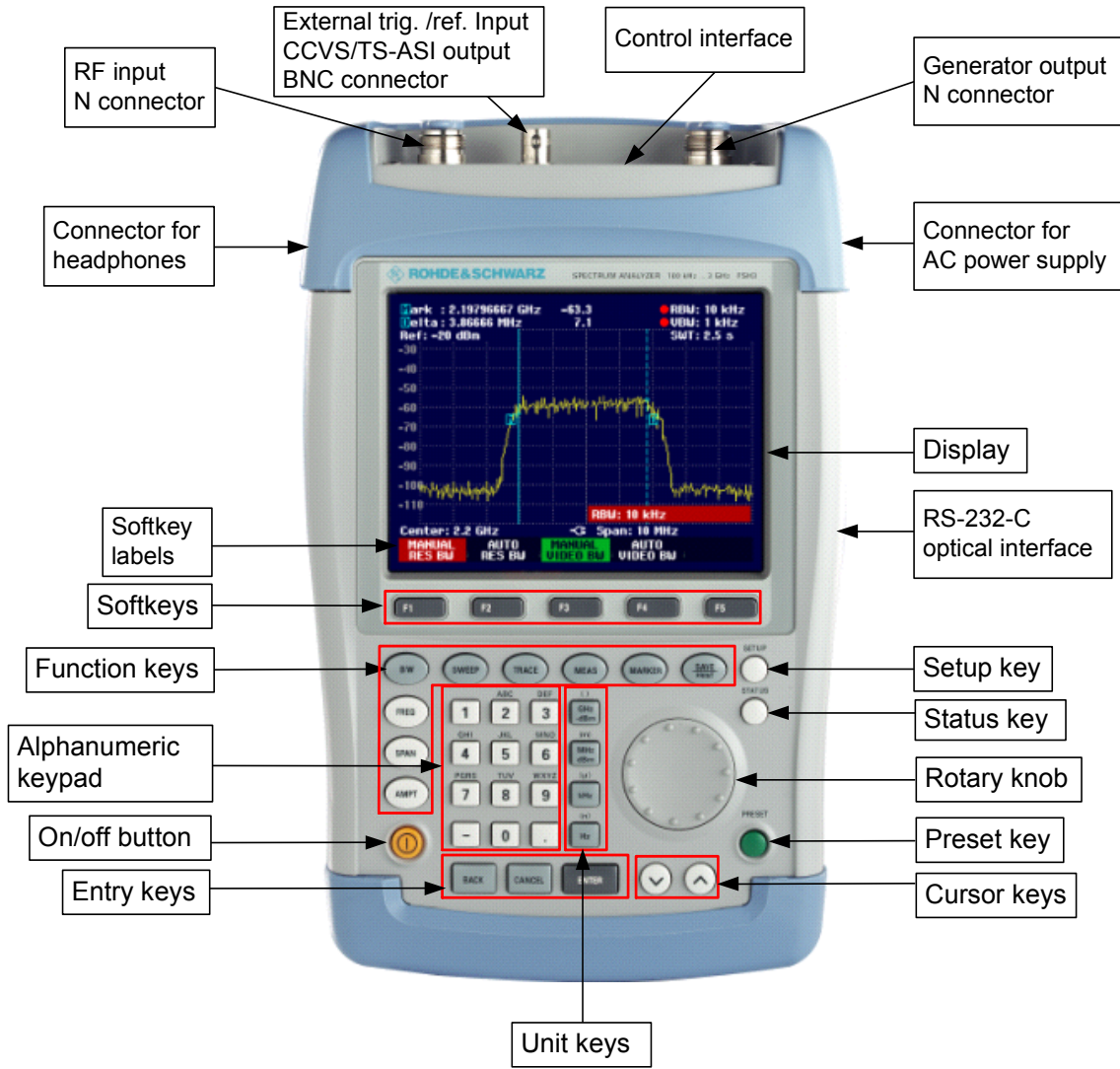

## Putting into Operation

The following section describes how to put the handheld spectrum analyzer into operation and how to connect external devices, e.g. printers.

Section 2 describes the operation of the spectrum analyzer using simple measurements as examples.

## Unpacking the Instrument

The R&S FSH3-TV comes in formfitting packaging that consists of upper and lower shells. The two shells are held together by tape.

The packaging contains all accessories supplied.

- Undo the tape to unpack the analyzer.

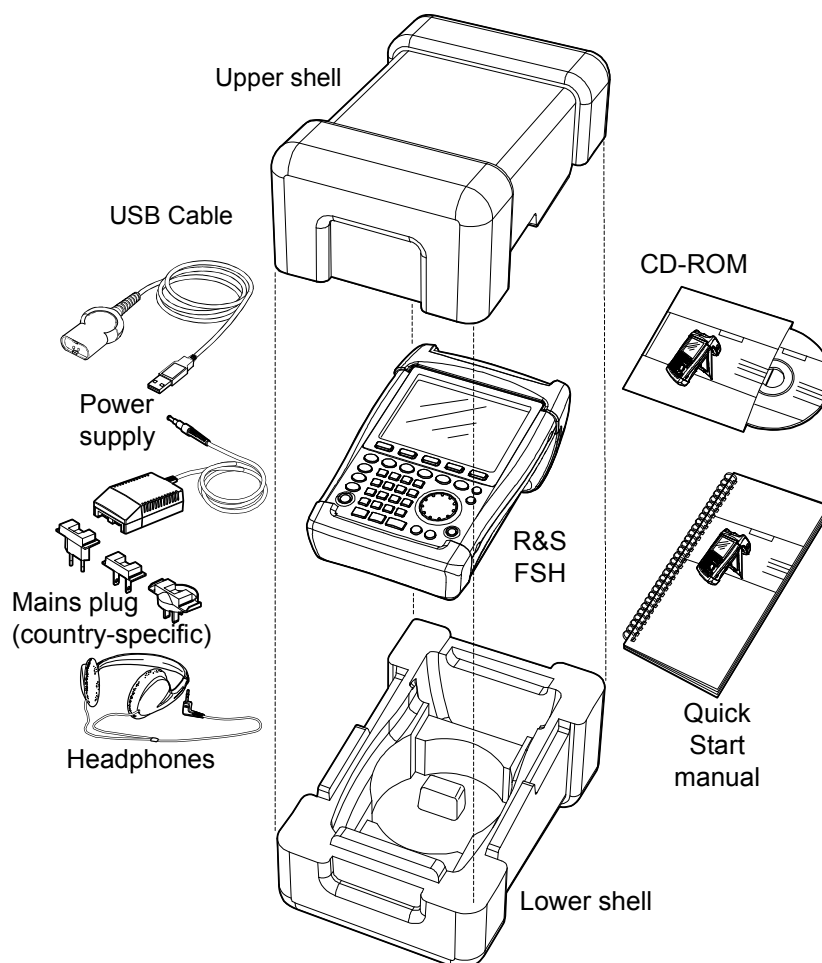

- Remove the R&S FSH3-TV and the accessories.
- Remove the protective foil from the screen.

**Note:** Each R&S FSH3-TV comes with a unique master PIN. Keep the master PIN in a secure place away from the R&S FSH3-TV. If someone enters an incorrect PIN three times in succession, the R&S FSH3-TV cannot be used again until the master PIN is entered.

## Setting up the Instrument

The handheld TV Analyzer R&S FSH3-TV has been designed for operation in labs as well as for on-site use for service and maintenance applications.

For any application, the R&S FSH3-TV can be set up to optimize ease of operation and the viewing angle of the display.

When used as a desktop instrument, the R&S FSH3-TV can either be laid flat or it can be propped up using the fold-out support at the back.

The R&S FSH3-TV can be laid flat for operation from above. Because the grip is slightly raised at the back, the R&S FSH3-TV is tilted forward to give the optimum viewing angle for the display.

For use as a desktop, fold out the support at the rear so that the instrument can easily be operated from the front and the display can be read easily (see Fig.).

For on-site installation and service measurements, it is best to hold the instrument with both hands. All the controls are easy to reach (e.g. with your thumbs). Use the R&S FSH-Z25 carrying bag so that you have both hands free to adjust the DUT. The R&S FSH3-TV can be placed in the hanger provided on the open bag for this purpose.



To secure the instrument in place, affix its carrying handle to the front of the carrying bag with the Velcro tape.

The carrying handle at the top of the R&S FSH3-TV can also be used to hang it from cabinet doors, for example. The shape of the grip ensures that the instrument does not fall off.



## Switching on the TV Analyzer

The R&S FSH3-TV can be powered using either the included power supply unit or internal battery. When fully charged, the built-in nickel metal hydride battery provides an operating time of three to four hours. On delivery, the battery in the R&S FSH3-TV may be flat. Therefore, it must be charged before the R&S FSH3-TV can be used. If the instrument is switched off, the charging time is about four hours.

When the adapter is used, the R&S FSH3-TV's battery is charged simultaneously. However, charging takes much longer if the R&S FSH3-TV is switched on. A battery that is almost flat should therefore be charged when the R&S FSH3-TV is off.

Insert the jack plug of the power supply unit into the POWER ADAPTER connector on the right-hand side of the carrying handle so that it locks into position. Then connect the power supply unit to an AC outlet. The voltage range of the power supply unit is 100 V to 240 V.

**Caution!** Only the supplied power supply unit – the R&S FSH-Z33 – may be used to power the R&S FSH3-TV or charge the battery from the AC supply.



Prior to use, make sure that the AC supply voltage is compatible with the voltage specified on the power supply unit. Before inserting the power supply unit into the AC power outlet, attach the appropriate adapter.

In vehicles, the battery can be charged from the cigarette lighter socket using the R&S FSH-Z21 cable.

**Caution!** It is strictly forbidden to operate the R&S FSH3-TV via the cigarette lighter socket while the vehicle is in motion or the engine is running. In these cases, the R&S FSH3-TV must be off.



While the battery of the R&S FSH3-TV is being charged via the 12 V Car Adapter R&S FSH-Z21, the car adapter must not be connected to the vehicle's ground (for example, via the RF connector) under any circumstances.

To switch on the R&S FSH3-TV, press the yellow button  at the bottom left of the front panel.

To indicate that it is connected to the AC supply, the R&S FSH3-TV displays a connector symbol in the middle of the display above the softkey labels.

Center: 1.5 GHz		-G Span: 3 GHz	
CENTER	CF	START	STOP
FREQ	STEP SIZE	FREQ	FREQ
			OFFSET

When the R&S FSH3-TV is switched on, it recalls the settings that it was using when it was last switched off.

**Note:** If the internal battery is completely flat, the R&S FSH3-TV cannot be switched on even though it is connected to the AC supply via the power supply unit. In this case, the internal battery must be charged for a while with the instrument switched off. Only then can the instrument be switched on.



## TV Analyzer Connectors

The R&S FSH3-TV has the following connectors:

### RF input

Connect the RF input via a cable with an N connector to the DUT. Make sure that it is not overloaded.

The maximum permissible continuous power at the RF input is 20 dBm (100 mW). It can be loaded with up to 30 dBm (1 W) for a maximum of three minutes. If the instrument is loaded with 1 W for longer, it heats up to such an extent that it may be destroyed.

**Caution!** *The RF input is AC-coupled. However, the DC input voltage must never exceed the value specified on the housing; otherwise the coupling capacitor at the input may be destroyed and, thus, the input attenuator or mixer as well. The RF input is protected from static discharges and voltage pulses by a combination of limiting circuits and high-voltage arresters.*



### Multifunctional BNC connector (EXT TRIG/REF CCVS/TS-ASI OUT)

The multifunctional BNC connector (**EXT TRIG/REF CCVS/TS-ASI OUT**) is used as an input and output connector for a number of R&S FSH3-TV functions. The connector is controlled via the SETUP – HARDWARE SETUP key.

- **Trigger signal input**  
Applies an external trigger signal to start a measurement. The trigger threshold is based on the trigger threshold of TTL signals. The input impedance is approx. 1 k $\Omega$ .
- **Video trigger input**  
Applies an external video signal for triggering to a TV line. The video amplitude must be in the range from 0.5 V to 2.0 V. A composite synchronous signal can also be applied for triggering. The input impedance is approx. 1 k $\Omega$ .
- **10 MHz reference input**  
Applies a 10 MHz signal for external frequency synchronization. The level for the reference signal must exceed 10 dBm. The input impedance is approx. 1 k $\Omega$ .
- **Video signal output**  
Output for the demodulated video signal in the analog TV receiver mode. The output is suitable for connecting a video analyzer (e.g. the R&S VSA) or a monitor. With standard-compliant modulation, the output signal has a video amplitude of 1 V at 75  $\Omega$ . The black level is connected to the DC voltage level of 0 V. The source impedance is 75  $\Omega$ .
- **TS-ASI output**  
Output for the TS-ASI signal in the digital TV receiver mode. The output is suitable for connecting an MPEG transport stream analyzer such as the R&S DVMD, R&S DVM 400, R&S DVM 100 or R&S DVM 50. The output amplitude is 0.8 V at 75  $\Omega$ . The source impedance is 75  $\Omega$ .

**DC connector for external power supply** (on the right-hand side of the carrying handle)

The DC connector is used to supply the R&S FSH3-TV with power from the AC/DC adapter and to charge the R&S FSH3-TV's internal battery. The input voltage for the instrument must be between 15 V and 20 V. Power consumption is between 7 W and 10 W, depending on the operating mode.

The battery can also be charged from a cigarette lighter socket in a vehicle. The adapter is available as an R&S FSH3-TV accessory (R&S FSH-Z21, order no. 1145.5873.02).

**Caution!** *While the battery of the R&S FSH3-TV is being charged via the 12 V Car Adapter R&S FSH-Z21, the car adapter must not be connected to the vehicle's ground (for example, via the R&S FSH3-TV's RF connector or the power sensor) under any circumstances.*

**Headphones connector** (on the left-hand side of the carrying handle)

A 3.5 mm jack is provided for headphones. The connector is also used as an audio measurement output in the analog TV receiver mode.

**Optical interface**

(on the right-hand side of the R&S FSH3-TV; can be accessed by folding out the stand)

The optical interface is for connecting a PC via a USB connector. The Spare USB Optical Cable R&S FSH-Z37 that comes with the R&S FSH3-TV is used to make the connection. The optical connection prevents spurious measurements as a result of interference from these devices.

Use the Serial/Parallel Converter R&S FSH-Z22 for printers with a parallel interface. Use the Spare RS-232-C Optical Cable R&S FSH-Z34 for connecting a PC or for printers with an RS-232-C interface.

**Connector for preselector, VSWR bridge, power divider and power sensor (CONTROL INTERFACE)**

The connector has been especially configured for the Preselector R&S FSH-TV-Z60 and the VSWR Bridge and Power Divider R&S FSH-Z2 as well as for Rohde & Schwarz power sensors. The connector is used to power and control these components and to transfer data.

**Tracking generator output (gen output)**

Connect the tracking generator output to the DUT via an N connector. The output level can be set between -20 dBm and 0 dBm.

**Caution!** *The output is AC-coupled and a voltage that does not exceed the voltage stated on the R&S FSH3-TV housing can be fed into the output; if this voltage is exceeded, the output may be destroyed.*



## Screen Settings

The R&S FSH3-TV's screen is a transfective, passive color LCD. Indoors, its brightness depends on the intensity of the backlighting. If light irradiation is strong, the ambient light supports readability. The viewing angle can be optimized by adjusting the contrast. To achieve maximum contrast, the screen can be switched from color display to black-and-white display.

To strike a balance between battery operating time and screen display quality, set backlighting to the minimum brightness needed.

### Setting brightness

- Press the SETUP key.
- Press the DISPLAY softkey.

The submenu with the contrast, lighting and color settings opens.



- Using the rotary knob or cursor keys, select LIGHT... and confirm by pressing the DISPLAY softkey or the ENTER key again.

The BACKLIGHT submenu for the lighting level opens. The level can be set to HIGH, NORMAL and LOW.

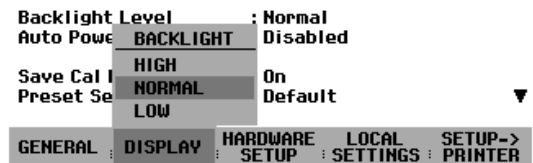

- Using the rotary knob or cursor keys, select the setting you want and confirm by pressing the DISPLAY softkey or the ENTER key.

### Setting the contrast

- Press the SETUP key.
- Press the DISPLAY softkey.

The submenu with the contrast, lighting and color settings opens.



- Using the rotary knob or the cursor keys, select CONTRAST... and confirm by pressing the DISPLAY softkey or the ENTER key again.

The contrast value entry box opens.



- Using the rotary knob, adjust the contrast until screen legibility is optimal.

When setting the contrast, view the display at the same angle that will be used for the application.

- Confirm the entry with the ENTER key or by pressing the DISPLAY softkey again.

The R&S FSH3-TV displays the setting in the Display Contrast line in the overview of the setup settings.

**Setting the screen color**

- Press the SETUP key.
- Press the DISPLAY softkey.

The submenu with the contrast, lighting and color settings opens.



- Using the rotary knob or cursor keys, select TYPE... and confirm with the ENTER key or by pressing the DISPLAY softkey again.
- In the submenu that opens, select COLOR or BLACK/WHITE.
- Confirm with the ENTER key or by pressing the DISPLAY softkey again.

The R&S FSH3-TV switches to the selected color settings.



## Country-Specific Settings

The R&S FSH3-TV is “multilingual” and can display text in the language of your choice. The softkey lettering is always in English. The default setting (factory-setting) is also English.

### Selection

- Press the SETUP key.

The R&S FSH3-TV displays all default settings. The last two lines indicate the current language and the date format.

- Press the LOCAL SETTINGS softkey.

A submenu with the LANGUAGE..., DATE FORMAT... and UNIT OF LENGTH... entries opens. This menu allows the entry of a country-specific language, date format or the unit of length used by the R&S FSH3-TV.

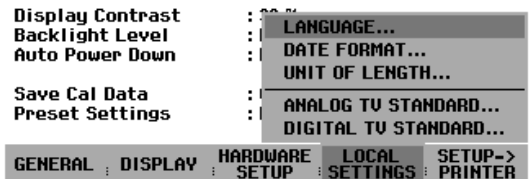

- Using the rotary knob or cursor keys, select the LANGUAGE... you want from the menu and confirm with the ENTER key or by pressing the LOCAL SETTINGS softkey again.

The languages available are displayed in a submenu. The selected language is highlighted in red.



- Using the rotary knob or cursor keys, select the language you want.

- Using the rotary knob or cursor keys, select DATE FORMAT... from the menu and confirm with the ENTER key or by pressing the LOCAL SETTINGS softkey again.
- Using the rotary knob or cursor keys, select the date format (dd/mm/yyyy or mm/dd/yyyy) and confirm with the ENTER key.
- Using the rotary knob or cursor keys, select UNIT OF LENGTH... from the menu and confirm with the ENTER key or by pressing the LOCAL SETTINGS softkey again.
- Using the rotary knob or cursor keys, select the required unit of length (METER or FEET) and confirm with the ENTER key.

*Note: The unit of length is relevant only with distance-to-fault cable measurements in order to display the fault distance from the measurement plane.*

## Setting the Date and Time

The R&S FSH3-TV has an internal clock that can apply a date and time stamp, e.g. for output to a printer or stored data records. The user can reset the date and time.

### Setting the date

- Press the SETUP key.
- Press the GENERAL softkey.
- Using the rotary knob or cursor keys, select DATE... from the menu and confirm with the ENTER key.

The value entry box above the row of softkey labels is highlighted in red and displays the currently set date in the selected format (dd/mm/yyyy or mm/dd/yyyy). The active value entry field is highlighted in white.

SAVE CAL DATA...	: 06.207
POWER DOWN...	: 115200
DATE...	: 19200
TIME...	: Laserjet
SERIAL BAUD...	: Off
PRINTER BAUD...	: 70 %
PRINTER TYPE...	: Normal
PINCODE...	: Disabled
OPTIONS...	: On
PRESET SETTINGS...	: Default
FACTORY	

GENERAL	DISPLAY	HARDWARE SETUP	LOCAL SETTINGS	SETUP-> PRINTER
---------	---------	----------------	----------------	-----------------

- Depending on the date format, change the day (dd) or month (mm) by using the rotary knob, cursor keys or a numeric entry and confirm with the ENTER key.

Display Contrast	: 62 %
Backlight Level	: Normal
Auto Power Down	: 5 minutes
Language	: English
Date Format	: dd/mm/yyyy
Length Unit	: Meter
Date	: 02/02/2003

GENERAL	DISPLAY	HARDWARE SETUP	LOCAL SETTINGS	SETUP-> PRINTER
---------	---------	----------------	----------------	-----------------

After the entry, the cursor automatically moves to the second field in the date (day or month, depending on the date format). Proceed with the next two fields as with the first.

After the last data block has been entered, the R&S FSH3-TV verifies the validity of the entered date. If the date is not valid, the R&S FSH3-TV sets the next valid date.

### Setting the time

- Press the SETUP key.
- Press the GENERAL softkey.
- Using the rotary knob or cursor keys, select TIME... from the menu and confirm with the ENTER key.

The value entry box above the row of softkey labels is highlighted in red and displays the currently set time in hours:minutes format. The hours display is highlighted in white to enter a new value.

SAVE CAL DATA...	: 06.207
POWER DOWN...	: 115200
DATE...	: 19200
TIME...	: Laserjet
SERIAL BAUD...	: Off
PRINTER BAUD...	: 70 %
PRINTER TYPE...	: Normal
PINCODE...	: Disabled
OPTIONS...	: On
PRESET SETTINGS...	: Default
FACTORY	

GENERAL	DISPLAY	HARDWARE SETUP	LOCAL SETTINGS	SETUP-> PRINTER
---------	---------	----------------	----------------	-----------------

- Change the hours with the rotary knob, cursor keys or numeric entry and confirm with the ENTER key.

Language	: English
Date Format	: dd/mm/yyyy
Length Unit	: Meter
Time	: 12:01

GENERAL	DISPLAY	HARDWARE SETUP	LOCAL SETTINGS	SETUP-> PRINTER
---------	---------	----------------	----------------	-----------------

After entry, the cursor automatically goes to the minutes display. The entry is the same as for the hours display.

After the minutes have been entered, the R&S FSH3-TV verifies the validity of the entered time. If the time is not valid, the R&S FSH3-TV sets the next valid time.

## Charging the Battery

The R&S FSH3-TV is fitted with a nickel metal hydride battery. The operating time is three to four hours at room temperature if the battery is fully charged.

*Note: The battery in the R&S FSH3-TV is not charged when it leaves the factory. It must therefore be charged after delivery.*

When stored over an extended period, self-discharging reduces the battery charge. The battery should therefore be charged before use if it is going to be the sole power source for a long period of operation.

The charging status of the battery is displayed by a symbol that looks like a battery in the middle of the screen above the row of softkey labels. If the battery is fully charged, the entire battery symbol is white. As the battery discharges, the white coloring disappears in five steps until just the battery outline indicates that the battery is flat.



Battery charge-level symbol

The battery is charged via the included power supply unit, which is connected to the jack on the right-hand side of the carrying handle.

If required, equip the power supply unit with the country-specific plug. Remove the plug from the power supply unit toward the front and firmly connect the appropriate plug to the power supply unit.

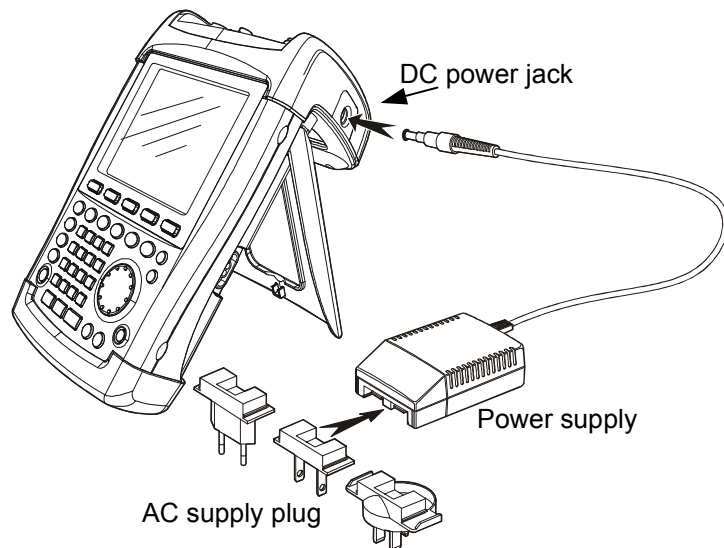

For rapid charging, be sure to switch off the R&S FSH3-TV during charging. The charging time is approx. four hours.

If the R&S FSH3-TV is switched on, the charging current for the battery is reduced by the current drain of the R&S FSH3-TV, which means the battery might not be charged.

To prevent the battery from discharging unnecessarily, the R&S FSH3-TV has an automatic cut-off or auto power down mode that is activated if no entry is made for a definable period of time (5 minutes or 30 minutes).

The auto power down mode is deactivated in the default setting.

The auto power down mode is set as follows:

- Press the GENERAL key.

The R&S FSH3-TV opens the submenu with the general settings. The cursor is positioned to POWER DOWN in the menu.

- Confirm the POWER DOWN selection by pressing the ENTER key.

The R&S FSH3-TV opens a selection window with the settings: 5 minutes, 30 minutes and DISABLE.

- Using the rotary knob or cursor keys, select the setting you want and confirm by pressing the ENTER key or the GENERAL softkey.

13/02/2003 INSTRUMENT SETUP 21:16:22	
Model Number	: FSH3
Serial Number	: 567890
Software Version	: D3.015
Printer Baudrate	: 19200
Printer Type	: Postscript
Pincode Protection	: Off
Display Contrast	: 50 %
Backlight Level	: Normal
Auto Power Down	: Disabled
<b>POWER DOWN</b>	
5 min.	: German
30 min.	: dd/mm/yyyy
DISABLE	: Meter
GENERAL : DISPLAY : <b>HARDWARE</b> : LOCAL : SETUP-> : PRINTER	

## Selecting the Instrument Default Setup

The PRESET key sets the R&S FSH3-TV to the default setup. This allows a new configuration based on defined measurement parameters to be entered, without parameters from a previous setting unintentionally still being active.

- Press the PRESET key.

The R&S FSH3-TV is set to the default setup.

If certain parameters are always to deviate from the default setup for a specific application, it is also possible to select a user-defined default setup, which is then automatically set with the PRESET key. This is useful, for example, if the measurement is always made with a 75 Ω matching pad. When the PRESET key is pressed, the R&S FSH3-TV always selects 75 Ω as the input impedance for the user-specific default setup. The user-defined default setup is generated by manually entering the desired parameters and saving the setting as a data set. This data set can subsequently be declared the preset settings with the aid of the R&S FSH View software.

The data set designated as the preset settings becomes the default setup of the R&S FSH3-TV as follows:

- Press the SETUP key.
- Press the GENERAL softkey.
- Select PRESET SETTINGS from the menu using the cursor keys or the rotary knob.
- Confirm your choice with the ENTER key or the GENERAL softkey.

SERIAL BAUD...	: Off
PRINTER BAUD...	: 70 %
PRINTER TYPE...	: Normal
PINCODE...	: Disabled
<b>OPTIONS...</b>	
PRESET SETTINGS...	: On
FACTORY	: Custom
GENERAL : DISPLAY : <b>HARDWARE</b> : LOCAL : SETUP-> : PRINTER	

The submenu for selecting the default setup opens. Either DEFAULT or CUSTOM can be selected.

- Select CUSTOM from the menu using the cursor keys or the rotary knob.
- Confirm your choice with the ENTER key or the GENERAL softkey.

Auto Power Down	: Disabled
<b>PRESET SETTINGS</b>	
DEFAULT	: On
CUSTOM	: Custom
GENERAL : DISPLAY : <b>HARDWARE</b> : LOCAL : SETUP-> : PRINTER	



The parameters defined in the data set for the default setup are now used as the preset settings. If no user-specific default setup is defined, CUSTOM is inactive and cannot be selected. The data set defined as the user default setup can be viewed using the R&S FSH3-TV's recall function.

- Press the SAVE/PRINT key.
- Press the RECALL softkey.

All stored data sets are displayed. The status of the data set is indicated in the status field:

- P**: Preset setting
- 🔒**: Data set disabled

If no data sets are stored in the R&S FSH3-TV, the message "No datasets available" is output instead of the list of data sets.

Dataset Name	Date	Time	Status
ISDB-T OBW.001	18/04/2004	14:10:38	P
ISDB-T OBW.000	23/12/2003	23:45:27	🔒
ISDB-T CHPwr.000	19/12/2003	23:56:07	🔒
ATSC CHPwr.001	19/12/2003	23:46:52	🔒
75-Ohm-Config.000	09/11/2003	21:38:24	🔒

Data set overwritable  
 Data set not overwritable or deletable

Status field  
 User-defined default setup

DELETE ALL : DELETE : EXIT : RECALL : LIST-> PRINTER

## Multifunctional BNC Connector Control

The EXT TRIG/REF CCVS/TS-ASI OUT BNC connector on the top of the R&S FSH3-TV can be used as an input and output connector for a number of instrument functions.

- **Trigger signal input**  
Applies an external trigger signal to start a measurement.
- **Video trigger input**  
Applies an external video signal for triggering to a TV line.
- **10 MHz reference input**  
Applies a 10 MHz signal for external frequency synchronization.
- **Video signal output**  
Output for the demodulated video signal in the analog TV receiver mode.
- **TS-ASI output**  
Output for the TS-ASI signal in the digital TV receiver mode.

Control is via the SETUP menu.

- Press the SETUP key.
- Press the HARDWARE SETUP softkey.
- Using the rotary knob or cursor keys, select BNC I/O MODE... and confirm with the ENTER key or the HARDWARE SETUP softkey.

The active setting for the multifunctional BNC connector is highlighted in green.

Using the rotary knob or the cursor keys, select TS-ASI OUT, CCVS OUT, EXT REF or EXT TRIG.

Serial Baudrate : 115200  
 Printer Baudrate : 19200  
 Printer Type : Laserjet  
 Pincode Protection : Off

Display Contrast : 50 %  
 Backlight Level : BRIDGE...  
 Auto Power Down : PRESELECTOR...

Save Cal Data : PREAMP...  
 Preset Settings : DYNAMIC RANGE...  
 BNC I/O MODE...

GENERAL : DISPLAY : HARDWARE SETUP : LOCAL SETTINGS : SETUP-> PRINTER

- Confirm your selection with the ENTER key or the HARDWARE SETUP softkey.

The EXT TRIG setting is only for input configuration. The use of the external trigger must be set in the SWEEP menu (SWEEP key, TRIGGER softkey).

The TS-ASI OUT setting can only be selected in digital TV receiver mode.

The CCVS OUT setting can only be selected in analog TV receiver mode.

The input setting can be queried via the status display (press the STATUS key).

## Controlling the RF Attenuator

Depending on the selected reference level, the R&S FSH3-TV sets the attenuator on the RF input to a suitable value. It offers two modes: one for the highest possible sensitivity (LOW NOISE) and one for the lowest possible intermodulation products (LOW DISTORTION). The difference between the two modes is that the attenuation that the R&S FSH3-TV sets for the RF attenuator is 10 dB higher for LOW DISTORTION than for LOW NOISE.

- Press the SETUP key.
- Press the HARDWARE SETUP softkey.
- Using the rotary knob or cursor keys, select DYNAMIC RANGE... from the menu.



- Confirm with the ENTER key or the HARDWARE SETUP softkey.
- Using the rotary knob or cursor keys, select LOW NOISE or LOW DISTORTION.

Confirm with the ENTER key or the HARDWARE SETUP softkey.

## Using a Preamp

The R&S FSH3-TV comes with an internal preamp for increasing sensitivity. Depending on the frequency, this amplifier has 15 dB to 18 dB gain and increases sensitivity by 10 to 15 dB. It is fitted behind the RF attenuator and in front of the input mixer.

- Press the SETUP key.
- Press the HARDWARE SETUP softkey.
- Using the rotary knob or cursor keys, select PREAMP... .
- Confirm with the ENTER key or the HARDWARE SETUP softkey.

The R&S FSH3-TV changes to the submenu for preamp configuration. The selection bar indicates the active setting.

- Using the rotary knob or cursor keys, select the setting you want (ON or OFF) and confirm by pressing the ENTER key.

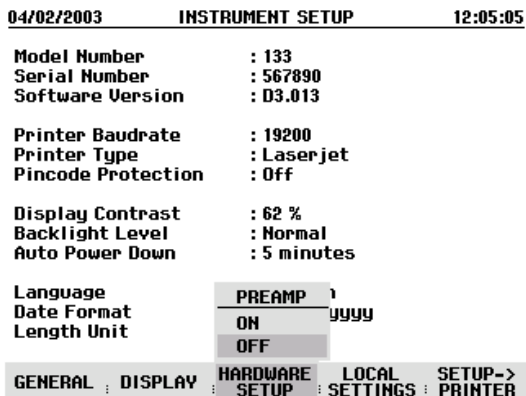

If the preamp is switched on, its use is coupled to the reference level, thus ensuring the optimum dynamic range of the R&S FSH3-TV at all times. The table below shows the positions of the RF attenuator and the preamp as a function of the reference level.

Ref Level	Preamp OFF		Preamp ON		Preamp
	RF attenuation		RF attenuation		
	Low noise	Low distortion	Low noise	Low distortion	
≤-25 dBm	0 dB	0 dB	0 dB	0 dB	On
-24 dBm to -20 dBm	0 dB	0 dB	10 dB	10 dB	On
-19 dBm to -15 dBm	0 dB	10 dB	10 dB	10 dB	On
-14 dBm to -10 dBm	0 dB	10 dB	0 dB	10 dB	Off
-9 dBm to 0 dBm	10 dB	20 dB	10 dB	20 dB	Off
1 dBm to 10 dBm	20 dB	30 dB	20 dB	30 dB	Off
11 dBm to 20 dBm	30 dB	30 dB	30 dB	30 dB	Off

The attenuator position can be queried at any time via the status display.

## PIN Entry

To prevent unauthorized use, the R&S FSH3-TV can be protected with a personal identification number (PIN).

When the R&S FSH3-TV is delivered, the PIN is set to 0000 and PIN entry is disabled when the R&S FSH3-TV is switched on. A PIN, i.e. a four-digit number, can be re-entered whenever you wish. But it is not activated until the PIN mode has been enabled.

A new PIN is entered as follows:

- Press the SETUP key to call up the SETUP menu and the instrument settings.
- Press the GENERAL softkey.

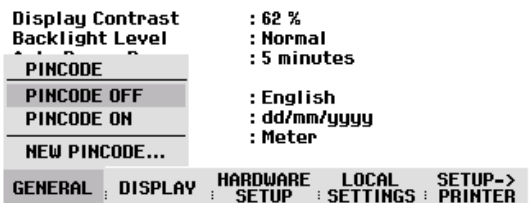

Using the rotary knob or cursor keys, select PINCODE... from the menu and press the ENTER key. The selection box with the PIN settings is opened.

The current PIN must be entered before it can be modified. This prevents unauthorized PIN modification.

- Enter your valid PIN.

### When the R&S FSH3-TV is delivered, the valid PIN is 0000.

After you enter your valid PIN, the PIN functions can be selected from the selection box. When the R&S FSH3-TV is delivered, a new PIN can be activated only if it differs from the factory-set PIN.

*Note: Before you activate the PIN mode, enter a user-defined PIN. Keep your PIN in a secure place away from the R&S FSH3-TV. If the active PIN is not available, the instrument can be reset to the default PIN ('0000') with the master PIN supplied with each instrument. If the master PIN is not available, please contact an authorized Rohde & Schwarz service center.*

### Entering a new PIN

- Using the rotary knob or cursor keys, select New Pincode... from the menu in the selection box and enter a new four-digit PIN. Confirm with ENTER.

The R&S FSH3-TV will prompt you to re-enter the PIN in order to prevent incorrect entries.

- Re-enter the PIN.

**Activating the PIN mode**

- Using the rotary knob or cursor keys, select PINCODE ON from the menu and press the ENTER key.

The R&S FSH3-TV now prompts you to enter the PIN prior to its activation.

- Enter the PIN and confirm with the ENTER key.

The selected PIN is now activated. The next time you switch on the R&S FSH3-TV, you must enter the PIN before you can operate the instrument. If you enter an incorrect PIN, the R&S FSH3-TV again prompts you for the PIN code. After three attempts with an incorrect PIN, the R&S FSH3-TV prompts you for the master PIN.

*Note: The R&S FSH3-TV comes with labels reading 'PIN Code protected'. If the instrument is protected with a PIN, affix one of these labels to the instrument. This warns unauthorized users that they cannot operate the R&S FSH3-TV.*

**Deactivating PIN protection**

- Using the rotary knob or cursor keys, select PINCODE OFF from the menu and press the ENTER key.

Prior to deactivation, the R&S FSH3-TV prompts you to enter your PIN. This prevents unauthorized deactivation of PIN protection.

- Enter your PIN number and confirm with the ENTER key.

The R&S FSH3-TV can now be operated without PIN protection.

## Connecting a Printer

The R&S FSH3-TV can output a screenshot to a connected printer. The Serial/Parallel Converter R&S FSH-Z22 is available as an accessory for printers with a parallel interface. The Spare RS-232-C Optical Cable R&S FSH-Z34 is available as an accessory for printers with an RS-232-C interface.

A printer with an RS-232-C interface can be directly connected using the RS-232-C optical interface cable that is supplied.

- Fold out the stand at the rear of the R&S FSH3-TV.
- Connect the optical connector of the RS-232-C cable to the optical interface on the right-hand side of the R&S FSH3-TV.
- Connect the RS-232-C connector of the cable to the printer.

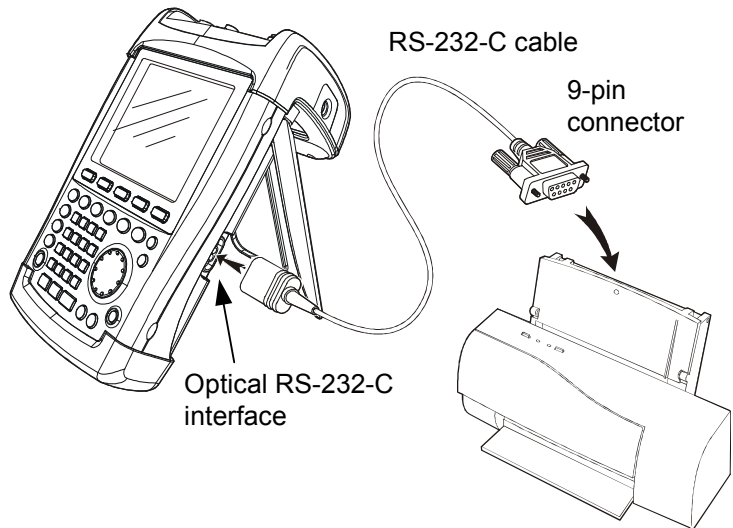

Connect printers with a parallel interface to the R&S FSH3-TV using the Serial/Parallel Converter R&S FSH-Z22, thus freeing up the Centronics parallel interface to connect a printer. The R&S FSH-Z22 is powered by a 9 V alkaline battery (NEDA, IEC6LR61).

- Fold out the stand at the rear of the R&S FSH3-TV.
- Connect the optical connector of the R&S FSH-Z22 to the optical interface on the right-hand side of the R&S FSH3-TV.
- Connect the printer cable to the 25-pin interface of the R&S FSH-Z22.
- Switch on the serial/parallel converter using the slide switch on its top.

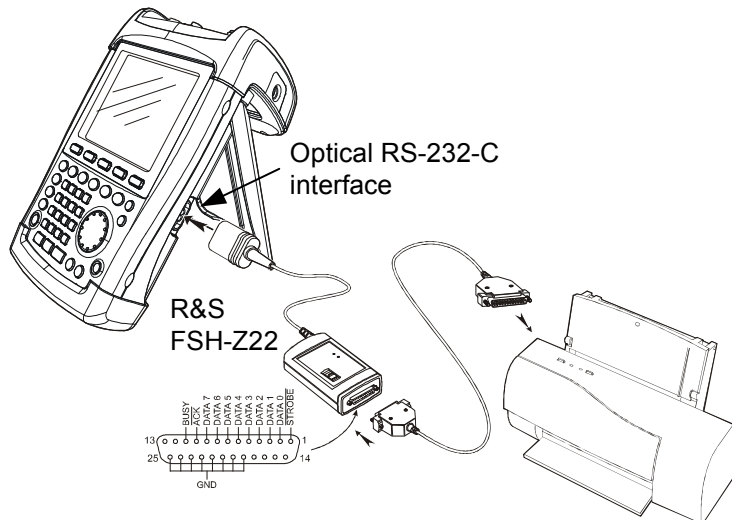

Slide switch positions:

- OFF The R&S FSH-Z22 is off.
- ON The R&S FSH-Z22 is on, and the Battery OK LED flashes.
- AUTO OFF The R&S FSH-Z22 is on, and the Battery OK LED flashes. If data transmission is interrupted for more than 5 minutes, the R&S FSH-Z22 is switched off automatically.

While data is being transmitted to the printer, the "Busy" LED remains lit.

*Note: The R&S FSH-Z22 is designed for a data transmission rate of max. 38 400 baud (= default setting). Therefore, set the baud rate (PRINTER BAUD RATE) in the SETUP menu to 38 400 baud. The baud rates 9600 baud and 19 200 baud can also be set on the R&S FSH-Z22 by opening its housing.*

**Selecting a printer**

- Press the SETUP key on the R&S FSH3-TV.

The R&S FSH3-TV displays the selected printer and its baud rate in the setup settings.

To select another printer, proceed as follows:

- Press the GENERAL softkey.
- Using the rotary knob or cursor keys, select PRINTER TYPE... from the menu and confirm with the ENTER key or by pressing the GENERAL softkey again.



- Using the rotary knob or cursor keys, select the printer you want and confirm with the ENTER key or by pressing the GENERAL softkey again.

The R&S FSH3-TV displays the selected printer under "Printer Type".

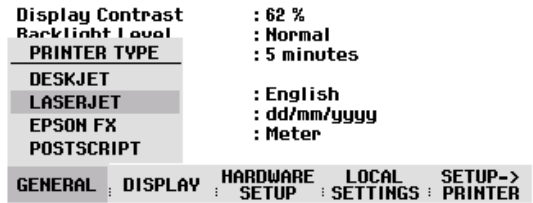

Next, set the baud rate for the selected printer.

- Press the GENERAL softkey.
- Using the rotary knob or cursor keys, select PRINTER BAUD... from the menu and confirm with the ENTER key.



The selection box for the available baud rates (1200 baud to 115 200 baud) opens.

- Using the rotary knob or cursor keys, select the baud rate you want and confirm with the ENTER key or by pressing the GENERAL softkey a second time.

The R&S FSH3-TV displays the selected baud rate under "RS232 Baudrate" in the setup display.

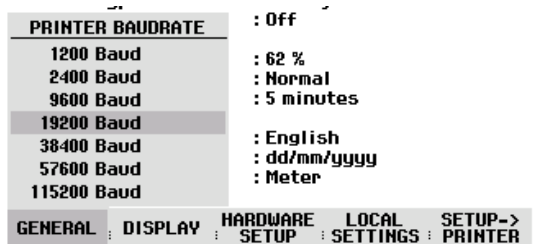

*Note: If the serial/parallel converter (R&S FSH-Z22) is used to control a printer with a parallel interface, set the RS-232-C interface to 38 400 baud.*

The contents of the setup display can be output to the printer by pressing the SETUP -> PRINTER softkey.

## Setting the Baud Rate for Remote Control

The R&S FSH3-TV offers different baud rates for remote control. The desired baud rate is set via the SETUP menu.

- Press the SETUP key.
- Press the GENERAL softkey.
- Use the rotary knob or the cursor keys to select SERIAL BAUD... from the menu and confirm the selection with the ENTER key.

SAVE CAL DATA...	: 07.001			
POWER DOWN...				
DATE...	: 115200			
TIME...	: 19200			
SERIAL BAUD...	: Laserjet			
PRINTER BAUD...	: Off			
PRINTER TYPE...	: 50 %			
PINCODE...	: Normal			
	: Disabled			
OPTIONS...				
PRESET SETTINGS...	: Off			
FACTORY	: Default			
GENERAL	DISPLAY	HARDWARE	LOCAL	SETUP->
		SETUP	SETTINGS	PRINTER

The selection box for the available baud rates (9600 baud to 115200 baud) opens.

- Use the rotary knob or the cursor keys to select the baud rate you want and confirm the entry with the ENTER key or by pressing the GENERAL softkey again.

SERIAL BAUDRATE	: 50 %			
9600 Baud	: Normal			
19200 Baud	: Disabled			
38400 Baud				
57600 Baud	: Off			
115200 Baud	: Default			
GENERAL	DISPLAY	HARDWARE	LOCAL	SETUP->
		SETUP	SETTINGS	PRINTER

The R&S FSH3-TV displays the selected baud rate under SERIAL BAUDRATE in the setup display.

## Enabling Options

The R&S FSH3-TV can be fitted with options (e.g. distance-to-fault measurements on cables) which are enabled by entering a key code. The key code is based on the unique serial number of the instrument. To add an option, enable it with a key code.

### Operation

- Press the SETUP key.
- Press the GENERAL key.
- Using the rotary knob or cursor keys, select OPTIONS... from the menu and confirm with the ENTER key.

Enter the key code (ten-digit number) for the option with the numeric keys and confirm with the ENTER key.

If the correct key code is entered, the R&S FSH3-TV displays "<...> Option enabled".

If an invalid key code is entered, the R&S FSH3-TV displays "Option key error".

The correct key code can then be entered.



## Checking the Installed Options

The R&S FSH3-TV displays the installed options in the SETUP menu so you can check them:

- Press the SETUP key.
- Using the rotary knob or the cursor keys, scroll the status display downwards.

The R&S FSH3-TV displays all available options together with their current status.

24/09/2004	INSTRUMENT SETUP	10:27:35
Display Contrast	: 75 %	▲
Backlight Level	: High	
Auto Power Down	: Disabled	
Save Cal Data	: On	
Preset Settings	: Custom	
Language	: English	
Date Format	: dd/mm/yyyy	
Length Unit	: Meter	
Distance to Fault (B1)	: Installed	
Vector Calibration (K2)	: Installed	
Remote Control (K1)	: Installed	
Receiver Mode (K3)	: Installed	

GENERAL	DISPLAY	HARDWARE	LOCAL	SETUP->
		SETUP	SETTINGS	PRINTER

## 2 Getting Started

This section explains the basic operation of the handheld TV Analyzer R&S FSH3-TV. A more detailed description of operation and functions, such as selecting menus and setting measurement parameters plus a description of the setup and of the displays, is provided in sections 3 and 4 of this manual.

### Measurements with the Spectrum Analyzer

#### Sinewave Signal Measurement

A basic task performed by spectrum analyzers is measuring the level and frequency of sinewave signals. The following examples illustrate the most effective way of performing these measurements with the handheld TV Analyzer R&S FSH3-TV.

A signal generator is used as a signal source, e.g. the Signal Generator R&S SML.

##### Measurement setup:

Connect the RF output of the signal generator to the RF input of the R&S FSH3-TV.

Signal generator settings:

Frequency      100 MHz  
Level            -30 dBm

#### Level Measurement

First, set the R&S FSH3-TV to its default settings to show all the operating steps that are required.

➤ Press the PRESET key.

The analyzer displays the frequency spectrum from 100 kHz to 3 GHz – the R&S FSH3-TV's entire frequency span. At 100 MHz, the generator signal is displayed as a vertical line. Generator harmonics can also be seen as lines at frequencies that are multiples of 100 MHz.

To analyze the generator signal at 100 MHz in more detail, reduce the frequency span of the R&S FSH3-TV. Set the R&S FSH3-TV's center frequency to 100 MHz and reduce the span to 10 MHz.

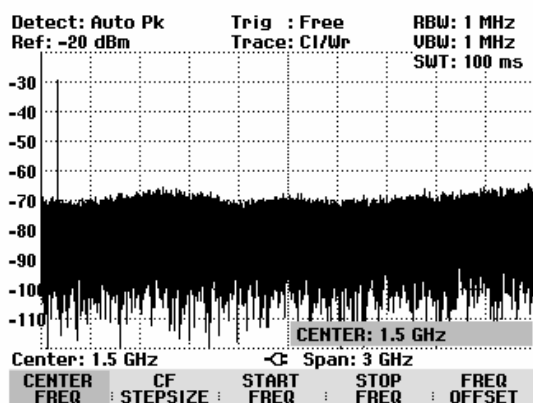

- Press the **FREQ** key.
- Enter “100” using the numeric keypad and confirm the entry with the **MHz** key.
- Press the **SPAN** key.
- Enter “10” using the numeric keypad and confirm the entry with the **MHz** key.

The R&S FSH3-TV now displays the generator signal with a higher resolution.

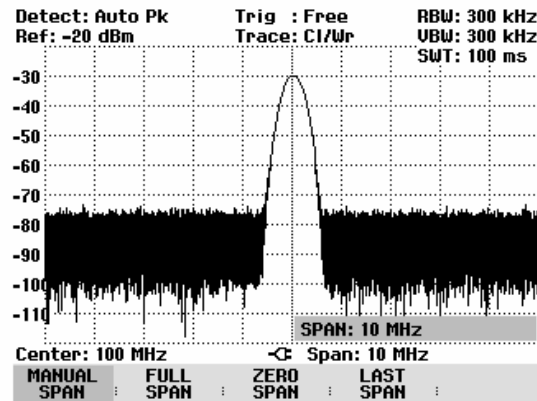

The R&S FSH3-TV has markers for determining signal levels. Markers are always positioned on the trace. Both the level and frequency at their current positions are displayed on the screen.

- Press the **MARKER** key.

The marker is activated and is automatically positioned on the trace maximum. A vertical line on the measurement diagram indicates the marker frequency. A short horizontal line on the trace indicates the level.

The R&S FSH3-TV displays the marker frequency and level numerically at the top of the measurement diagram.

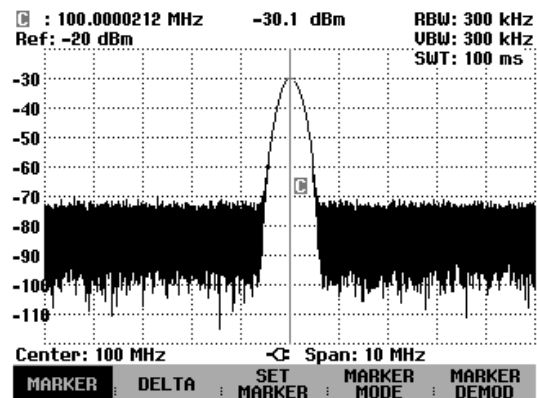

## Setting the Reference Level

The level shown by spectrum analyzers at the top of the measurement diagram is called the reference level (REF LEVEL). To obtain the best dynamic range from a spectrum analyzer, its full level range should be used. This means that the maximum spectrum level should be at or close to the top of the measurement diagram (= reference level). The reference level is the maximum level on the level axis (y axis).

Reduce the reference level by 10 dB to increase the dynamic range.

- Press the **AMPT** key.

The softkeys for the AMPT menu are displayed and the **REF LEVEL** softkey label is highlighted in red, i.e. it is enabled for value entry. The red value entry box at the bottom right-hand corner of the measurement diagram displays the current reference level.

- Enter “30” using the numeric keypad and confirm the entry with the **dBm** key.

The reference level is now set to -30 dBm. The maximum trace value is close to the maximum scale value of the measurement diagram. The increase in the displayed noise floor is minimal. The difference between the signal maximum and the displayed noise (i.e. the dynamic range) has, however, been increased.

Using markers is also an effective way to shift the trace maximum so that it coincides with the top of the measurement diagram. If the marker is positioned on the trace maximum (as in the example), the reference level can be set to the marker level by entering the following keystrokes:

- Press the MARKER key.
- Press the SET MARKER softkey.
- Select REF LVL = MRK LVL in the submenu by using the rotary knob or the cursor keys.
- Press the ENTER key.

The reference level is then set to the measured level indicated by the marker. Only a few keystrokes are needed to set the optimal reference level.

## Frequency Measurements

The R&S FSH3-TV's trace displays 301 measurement points (frequency points). The marker is always positioned on one of these measurement points. The R&S FSH3-TV calculates the marker frequency from the measurement-point frequency, and the center frequency and frequency span that have been set. The measurement point resolution and, consequently, the accuracy of the marker-frequency readout therefore depend on the frequency span that has been selected.

The R&S FSH3-TV has a frequency counter to increase the accuracy of the marker frequency readout. It stops the sweep at the marker position, counts the frequency and then continues the sweep.

The following measurement example is based on the previous example.

- Press the MARKER MODE softkey in the marker menu.

The marker mode selection box opens.

- Select FREQ COUNT from the selection box using the rotary knob or the cursor keys.
- Press the ENTER key.

The label 'M' at the upper left-hand corner of the measurement diagram changes to 'C' to tell you that the frequency counter has been switched on. The resolution of the frequency readout is now 1 Hz no matter what span has been set. The accuracy is determined by the R&S FSH3-TV's internal reference frequency. It is far higher than that of pixel-oriented, marker-frequency readout.

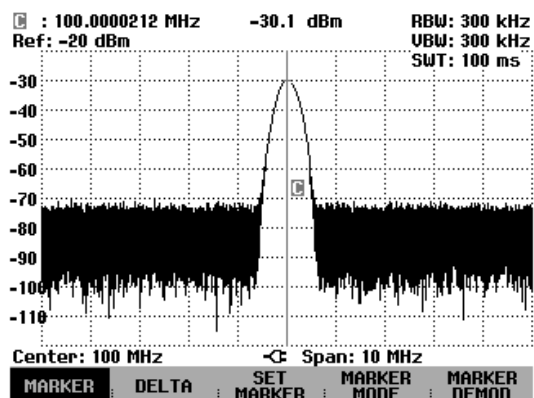

## Harmonic Measurements of a Sinewave Signal

Since a spectrum analyzer can resolve different signals in the frequency domain, it is ideal for measuring harmonic levels or harmonic ratios. To speed up these operations, the R&S FSH3-TV has marker functions that deliver fast results with only a few keystrokes.

As above, a signal generator with a 100 MHz output frequency and an output level of  $-20$  dBm is used in the following measurement example.

First, the R&S FSH3-TV is set to its default settings to show all measurement steps that are needed.

- Press the PRESET key.  
The analyzer displays the frequency spectrum from 100 kHz to 3 GHz – the R&S FSH3-TV's entire frequency span. At 100 MHz, the generator signal is displayed as a line. The generator harmonics are displayed as lines at frequencies that are multiples of 100 MHz.

To measure the second harmonic ratio, set the start and stop frequency as follows:

- Press the FREQ key.  
The softkey menu opens entering the frequency.
- Press the START softkey.
- Enter '50' using the numeric keypad and confirm the entry with the MHz key.
- Press the STOP softkey.
- Enter '250' using the numeric keypad and confirm the entry with the MHz key.

The R&S FSH3-TV now displays the spectrum from 50 MHz to 250 MHz and thus the signal at 100 MHz and its second harmonic at 200 MHz.

To measure the harmonic ratio, set the marker on the fundamental and the delta marker on the second harmonic.

- Press the MARKER key.

The softkey menu opens for marker entry and automatically positions the main marker on the trace maximum.

- Press the DELTA softkey.

The delta marker is activated (vertical dotted line) and is automatically placed on the next trace maximum (= second harmonic).

The harmonic ratio in dB can be read directly from the numeric delta-marker display.

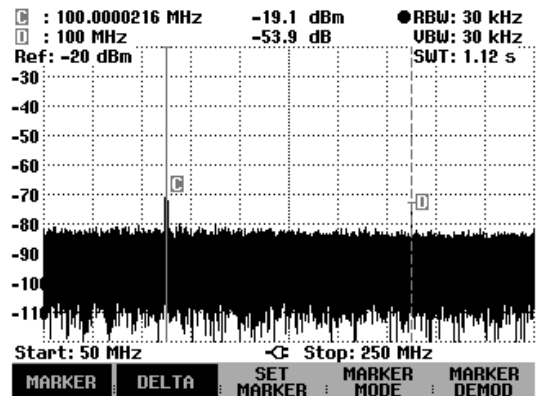

# Measurements on Analog TV Signals

## Measuring the Video-Signal-to-Noise Ratio

One of the main transmission parameters is the signal-to-noise ratio of the transmitted video signal. The following measurement example shows the individual steps used to effectively perform this measurement with the R&S FSH3-TV.

An analog TV test transmitter such as the TV Test Transmitter R&S SFM is used as a signal source together with the CCVS + Component Generator R&S SAF.

### Measurement setup:

Connect the R&S SAF video output to the R&S SFM video input, and the RF output of the analog TV test transmitter to the R&S FSH3-TV RF input.

Settings on the video signal generator:

Standard	PAL, 625 lines
CCIR 17	line 17
CCIR 330	line 330

Settings on the analog TV test transmitter:

Standard	B/G, FM-IRT-A2 dual-channel sound
Group delay	general
Frequency	210.25 MHz
Level	-17 dBm

Set the R&S FSH3-TV to its default settings to show all the operating steps that are required.

➤ Press the PRESET key.

The analyzer displays the frequency spectrum from 100 kHz to 3 GHz – the R&S FSH3-TV's entire frequency span. At 210.25 MHz, the generator signal is displayed as a vertical line. Generator harmonics can also be seen as lines at frequencies that are multiples of 210.25 MHz.

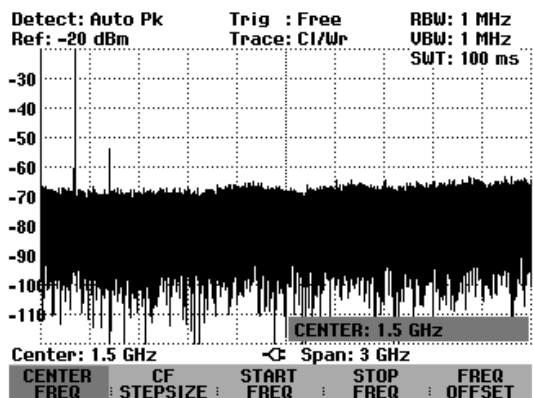

**Activating the analog TV receiver:**

Activate the ANALOG TV RECEIVER measurement to measure the signal-to-noise ratio.

- Press the MEAS key.
- Press the MEASURE softkey.
- Select ANALOG TV RECEIVER from the selection box using the rotary knob or the cursor keys and press the ENTER key.

The R&S FSH3-TV opens the analog TV receiver selection menu.

- Select MEASUREMENT LIST from the selection box using the rotary knob or the cursor keys and press the ENTER key.

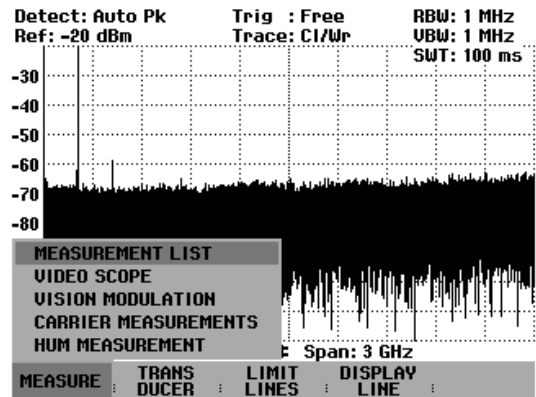

The R&S FSH3-TV activates the analog TV receiver. The result list is displayed, providing an overview of the default setting and the quality of the received TV signal.

ANALOG TV RECEIVER	
TV Std. - Group Delay	L - TDF
Sound Standard	AM 6.5 / NICAM 5.85
Vision Carrier Frequency	1.5 GHz
Channel	--
Sideband Position	Upper
RefLevel	TOO HIGH
Carrier Frequency Offset	---
Vision Detector	UNLOCKED
Sync Separator	---
Luminance Bar	---
S/N Video Weighted(bar/nom)	-- dB / -- dB
AM Sound Carrier	MISSING
NICAM Carrier	MISSING
NICAM Mode	MONO + DATA
NICAM BER	2.5E-2

**Setting the analog TV standard:**

- Press the SETUP key.
- Press the LOCAL SETTINGS softkey.
- Select ANALOG TV STANDARD... from the selection box using the rotary knob or the cursor keys and press the ENTER key.

The R&S FSH3-TV opens the analog TV standard menu.

- Select B... from the selection box using the rotary knob or the cursor keys and press the ENTER key.

Display Contrast	: 30%
Backlight Level	: 100%
Auto Power Down	: 10 min
Save Cal Data	: Off
Preset Settings	: Default

GENERAL	DISPLAY	HARDWARE SETUP	LOCAL SETTINGS	SETUP-> PRINTER
Serial Baudrate	: 115200			
Printer Baudrate	: 19200			
Printer Type	: Laser			
Pincode Protection	: Off			
Display Contrast	: 30%			
Backlight Level	: 100%			
Auto Power Down	: 10 min			
Save Cal Data	: Off			
Preset Settings	: Default			

The R&S FSH3-TV opens the menu for setting the country-specific group delay precorrection.

- Select GENERAL... from the selection box using the rotary knob or the cursor keys and press the ENTER key.

Serial Baudrate	: 115200	
Printer Baudrate	: 19200	
Printer Type	: Laserj	
Pincode Protection	: Off	
		<b>GROUP DELAY</b>
		GENERAL...
		AUSTRALIA...
		SWEDEN FULL...
		NORWAY...
		DANMARK...
		NEW ZEALAND...
		FLAT...
Display Contrast	: 30 %	
Backlight Level	: Normal	
Auto Power Down	: Disabl	
Save Cal Data	: Off	
Preset Settings	: Defaul	
		GENERAL : DISPLAY : <b>HARDWARE SETUP</b> : LOCAL SETTINGS : SETUP-> PRINTER

The R&S FSH3-TV opens the menu for setting the sound transmission standard.

- Select FM 5.5 / FM 5.742... from the selection box using the rotary knob or the cursor keys and press the ENTER key.

Display Contrast	: 30 %	
Backlight Level	: Normal	
Auto Power Down	: Disal	
		<b>SOUND</b>
		FM 5.5 / FM 5.742
		FM 5.5 / NICAM 5.85
		FM 5.5 MONO
Save Cal Data	: Off	
Preset Settings	: Defa	
		GENERAL : DISPLAY : <b>HARDWARE SETUP</b> : LOCAL SETTINGS : SETUP-> PRINTER

The R&S FSH3-TV adjusts the analog TV receiver to the B standard using the GENERAL group delay precorrection and the FM sound transmission method in accordance with IRT A2.

**Setting the receive frequency:**

- Press the FREQ key.

The R&S FSH3-TV opens the entry field for setting the vision carrier frequency.

- Using the numeric keypad, enter 210.25 and confirm the entry with the MHz key.

The R&S FSH3-TV sets the receive frequency to a vision carrier frequency of 210.250000 MHz.

The measurement screen displays the main status settings and provides an overview of the analog TV signal received.

ANALOG TV RECEIVER		
TV Std. - Group Delay	B - GENERAL	
Sound Standard	FM 5.5 / FM 5.742	
Vision Carrier Frequency	210.25 MHz	
Channel	--	
Reference Level	-20 dBm	TOO LOW
<hr/>		
Vision Carrier Level	-17.2 dBm	
Carrier Frequency Offset	0 kHz	
Vision Detector	LOCKED	
Sync Separator	H+U SYNC	
Luminance Bar	906.2 mV	
S/N Video Weighted(bar/nom)	57.5 dB / 55.2 dB	
FM Snd Carrier Deviation	30.0 kHz	
FM Snd Carrier Deviation	30.0 kHz	
FM Mode	STEREO	
		<b>UIS CARR: 210.25 MHz</b>
←		
CHANNEL CTR FREQ :	VISION CARRIER :	FREQ STEPSIZE :
		CHANNEL :
		CHANNEL TABLE :

**Setting the Quiet Line test line:**

The R&S FSH3-TV measures the noise power of the demodulated video signal in the Quiet Line.

- Press the MEAS key.
- Press the SET TEST LINE softkey.
- Select QUIET LINE from the selection box using the rotary knob or the cursor keys and press the ENTER key.

The R&S FSH3-TV opens the entry field for TV lines.

- Using the numeric keypad, enter 6 and confirm the entry with the ENTER key.

ANALOG TV RECEIVER		
TV Std. - Group Delay	B - GENERAL	
Sound Standard	FM 5.5 / FM 5.742	
Vision Carrier Frequency	210.25 MHz	
Channel	--	
Reference Level	-20 dBm	TOO LOW
<hr/>		
Vision Carrier Level	-17.2 dBm	
Carrier Frequency Offset	0 kHz	
Vision Detector	LOCKED	
Sync Separator	H+U SYNC	
Luminance Bar	897.8 mV	
S/N Video Weighted(	59.8 dB / 54.7 dB	
FM Snd Carrier Devi	30.0 kHz	
FM Snd Carrier Devi	30.0 kHz	
FM Mode	STEREO	
		<b>QUIET...</b>
		CCIR 17...
		FCC COMP...
		FCC COMP...
SELECT MEASURE :	LEVEL :	SET TEST LINE :
		AUDIO SOURCE :
		VOLUME :



**Setting the RF attenuator:**

Depending on the selected reference level, the R&S FSH3-TV provides the attenuator at the RF input. It offers two modes, the LOW NOISE mode for maximum sensitivity and the LOW DISTORTION mode for the lowest possible intermodulation products. The two modes differ in that the R&S FSH3-TV sets an RF attenuator attenuation that is 10 dB higher for LOW DISTORTION than it is for LOW NOISE.

In the measurement example, the RF signal only includes an analog TV signal. Use the LOW NOISE mode in this case.

- Press the SETUP key.
- Press the HARDWARE SETUP softkey.
- Select DYNAMIC RANGE from the selection box using the rotary knob or the cursor keys and press the ENTER key.
- Select the LOW NOISE mode from the selection box using the rotary knob or the cursor keys and press the ENTER key.

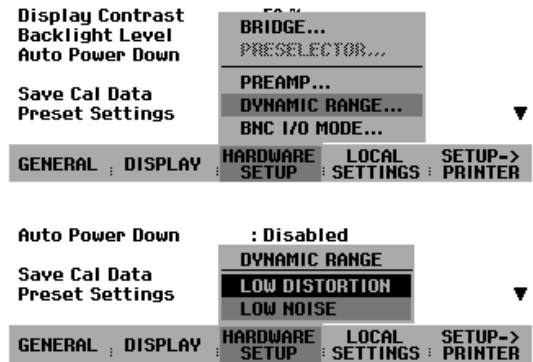

The reference level is set manually in the AMPT menu.

- Press the AMPT key.

The R&S FSH3-TV opens the entry field for setting the reference level. You can change the reference level using the rotary knob or the cursor keys, or you can enter a new value using the numeric keypad.

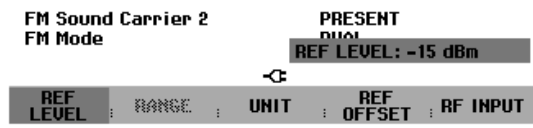

**Setting the reference level unit:**

The reference level can be entered in dBm, dBµV, dBmV, V or W.

- Press the AMPT key.
- Press the UNIT softkey.
- Select the unit you want by using the rotary knob or the cursor keys, and press the ENTER key or the UNIT softkey.

The reference level can now be set in the selected unit.

- Press the REF LEVEL softkey.

The R&S FSH3-TV opens the entry field for setting the reference level. You can change the reference level using the rotary knob or the cursor keys, or you can enter a new value using the numeric keypad.

Der aktuell eingestellte Referenzpegel wird im Messbildschirm angezeigt. Als Einstellhilfe wird in Klammern hinter dem Einstellwert die Differenz zum idealen Demodulatorpegel angezeigt.

**Automatic routine for setting the optimum reference level:**

To simplify operation and to avoid wrong settings, the R&S FSH3-TV is equipped with an automatic routine for setting the optimum reference level. A setting criterion for the Level Adjust function is the noise voltage of the demodulated video signal, which is measured in the Quiet Line test line. The Level Adjust function requires that the set Quiet Line test line not contain any modulation.

- Press the MEAS key.
- Press the LEVEL softkey.
- Select LEVEL ADJUST from the selection box using the rotary knob or the cursor keys and press the ENTER key.

The R&S FSH3-TV sets the optimum reference level.

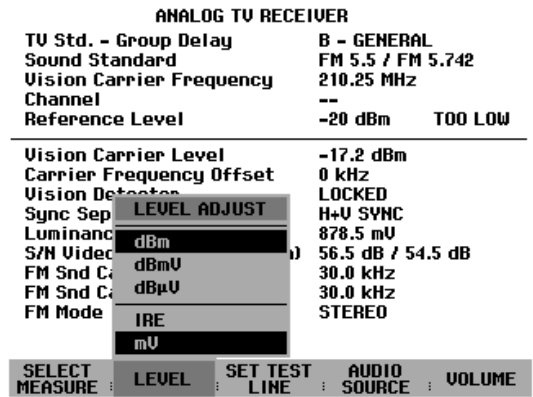

While the Level Adjust function is searching the optimum instrument setting, the screen displays this information as a message.

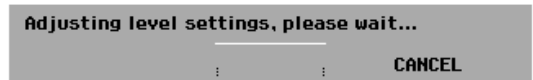

**Video-signal-to-noise measurement parameter:**

The R&S FSH3-TV measures the noise power in the Quiet Line, weights it in accordance with CCIR 567 and calculates its bar amplitude ratio. The R&S FSH3-TV displays two signal-to-noise ratio measurement parameters. It references the measured noise power to the nominal bar amplitude and to the measured bar amplitude. Both measurement values are displayed in the Measurement List screen.

With M/NTSC and M/PAL, the R&S FSH3-TV measures the bar amplitude either in the NTC7 COMP or FCC COMP test line; with all other standards, in the CCIR 17 test line.

To measure the bar amplitude correctly, the line number of the test line must correspond to the input signal.

In the measurement example, the CCIR 17 test line must correspond to line 17.

- Press the MEAS key until the analog TV receiver main menu pops up.
- Press the SET TEST LINE softkey.
- Select CCIR 17 from the selection box using the rotary knob or the cursor keys and press the ENTER key.

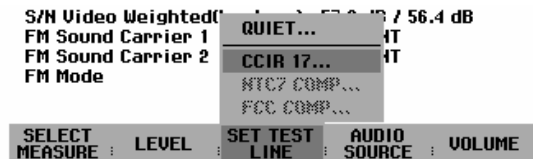

The R&S FSH3-TV opens the entry field for TV lines.

- Using the numeric keypad, enter 17 and confirm the entry with the ENTER key.



The signal-to-noise ratio weighted in accordance with CCIR 567 is displayed in the MEASUREMENT LIST screen.

The left measurement value is referenced to the measured bar amplitude, the right value to the nominal bar amplitude.

ANALOG TV RECEIVER		
TV Std. - Group Delay	B - GENERAL	
Sound Standard	FM 5.5 / FM 5.742	
Vision Carrier Frequency	210.25 MHz	
Channel	10	
Reference Level	-17 dBm	(0 dB)
Vision Carrier Level	-17.2 dBm	
Carrier Frequency Offset	0 kHz	
Vision Detector	LOCKED	
Sync Separator	H+V SYNC	
Luminance Bar	711.2 mV	
S/N Video Weighted(bar/nom)	54.5 dB / 54.3 dB	
FM Snd Carrier Deviation	30.0 kHz	
FM Snd Carrier Deviation	30.0 kHz	
FM Mode	STEREO	

←				
SELECT	LEVEL	SET TEST	AUDIO	VOLUME
MEASURE :	:	LINE :	SOURCE :	:

## Measurements Using the Video Oscilloscope

The R&S FSH3-TV is equipped with a video oscilloscope, which displays the demodulated video signal on the measurement screen. The video oscilloscope can be triggered either by the demodulated video signal or by an external video signal. The R&S FSH3-TV provides marker functions to analyze trace values.

In the following measurement example, the video amplitude is measured in the CCIR 330 test line. The example explains the individual steps used to effectively perform this measurement with the R&S FSH3-TV. The operating steps are based on the settings of the "Measuring the Video-Signal-to-Noise Ratio" measurement example.

An analog TV test transmitter such as the TV Test Transmitter R&S SFM is used as a signal source together with the CCVS + Component Generator R&S SAF.

### Measurement setup:

Connect the R&S SAF video output to the R&S SFM video input, and the RF output of the analog TV test transmitter to the R&S FSH3-TV RF input.

Settings on the video signal generator:

Standard	PAL, 625 lines
CCIR 17	line 17
CCIR 330	line 330

Settings on the analog TV test transmitter:

Standard	B/G, FM-IRT-A2 dual-channel sound
Group delay	general
Frequency	210.25 MHz
Level	-17 dBm

### Activating the video oscilloscope:

- Press the MEAS key until the ANALOG TV RECEIVER main menu pops up.
- Press the SELECT MEASURE softkey.
- Select VIDEO SCOPE from the selection box using the rotary knob or the cursor keys and press the ENTER key.

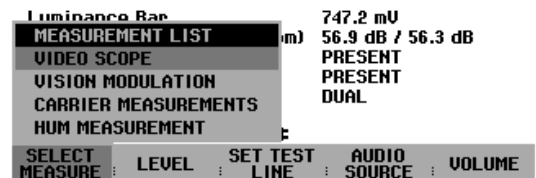

The measurement screen of the video oscilloscope is displayed. In the default setting, line 17 is displayed.

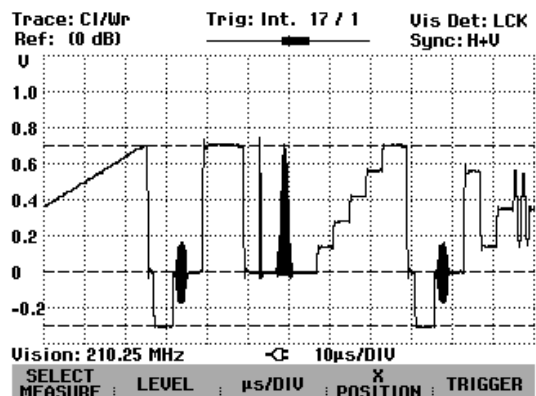

**Setting the trigger:**

Triggering occurs to a video line of the demodulated video signal or of an external video signal. For external triggering, set the multifunction connector in the Setup / Hardware Setup / BNC I/O Mode menu to EXT TRIG. The video amplitude must range between 0.5 V and 2.0 V.

In the measurement example, triggering occurs to line 330 of the internally demodulated video signal.

- Press the TRIGGER softkey.
- Select LINE... using the rotary knob or the cursor keys and press the ENTER key.

The R&S FSH3-TV opens the entry field for setting video line numbers.

- Using the numeric keypad, enter 330 and confirm the entry with the ENTER key.

Triggering occurs to the rising edge of the sync pulse of line 330.

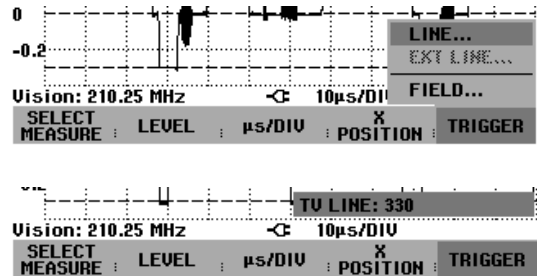

**Setting the time basis:**

The time basis can be set within the range from 1 μs/div to 50 μs/div. The default setting is 10 μs/div.

- Press the μs/DIV softkey.
- Select the time basis you need using the rotary knob or the cursor keys and press the ENTER key.

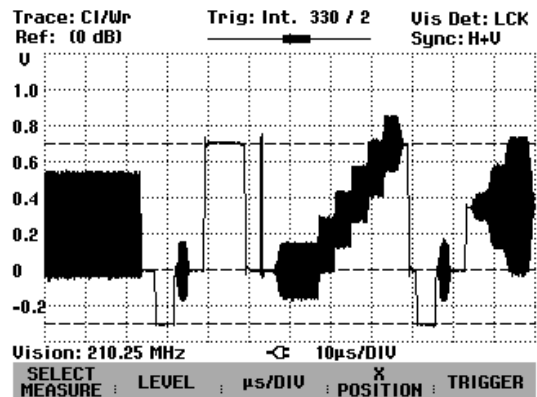

**Setting the X position:**

The time signal can be shifted along the X axis. The reference is the trigger time, which is in the center of the measurement screen when 0 is set. In the default setting, a shift of 32 μs is set. The selected trigger line is thus displayed in the center of the measurement screen.

- Press the X POSITION softkey.

The R&S FSH3-TV opens the entry field for shifting the measurement trace horizontally.

- Shift the displayed time signal using the rotary knob or the cursor keys, or enter a new value using the numeric keypad.

A positive setting shifts the displayed video signal toward the left; a negative setting shifts the signal toward the right. In the default setting, the video signal is shifted by 32 μs; as a result, the center of the line is output in the display center.

**Setting the markers:**

Using the markers, you can perform amplitude and time measurements.

- Press the MARKER softkey.
- Using the rotary knob, shift the marker approximately to the center of the white reference bar.

In the upper left corner of the measurement screen, the R&S FSH3-TV displays the amplitude of the white level referenced to the black level. An M precedes the measurement value.

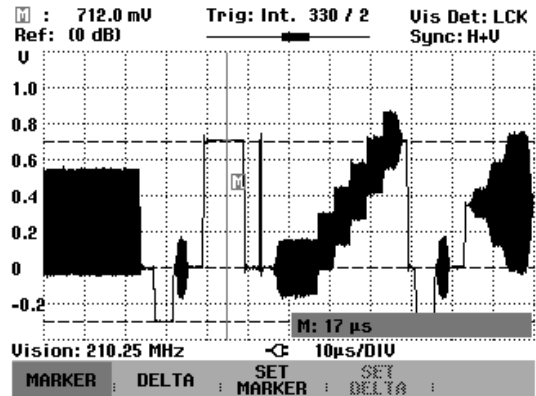

- Press the DELTA softkey.
- Using the rotary knob, shift the delta marker approximately to the center of the sync pulse.

In the upper left corner of the measurement screen, the R&S FSH3-TV displays the amplitude of the video signal. The letter D precedes the measurement value.

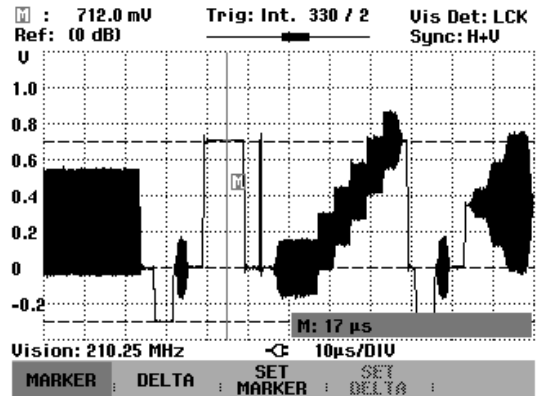

**Setting the trace averaging:**

You can average the trace, which is advisable for noisy signals.

- Press the TRACE key.
- Press the TRACE MODE softkey.
- Select AVERAGE from the selection box using the rotary knob or the cursor keys and press the ENTER key.

The R&S FSH3-TV opens the entry field for setting the averaging factor.

- Using the numeric keypad, enter 10 and confirm the entry with the ENTER key.

The R&S FSH3-TV averages the last ten traces. The current and the selected averaging factor are displayed at the lower right of the measurement screen.

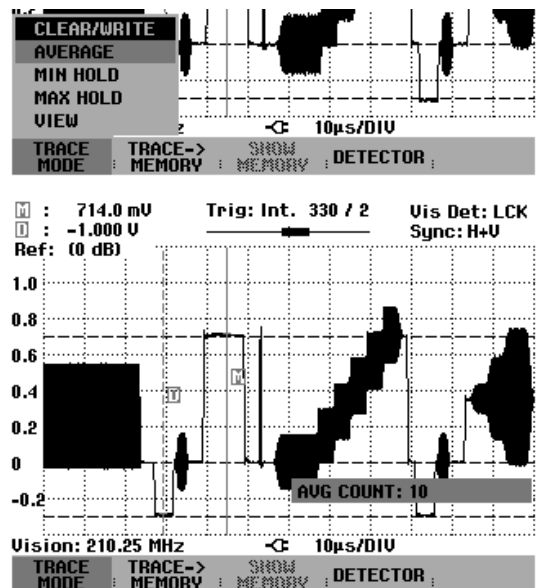

## Measuring the Vision Carrier Modulation Depth

To determine the modulation depth or the residual carrier, the R&S FSH3-TV measures the power and the level of the vision carrier versus time and displays the result on the measurement screen. Triggering can be executed either by the demodulated video signal or by an external video signal. The R&S FSH3-TV provides marker functions to analyze trace values.

In the following measurement example, the modulation depth is measured in the CCIR 330 test line. The example explains the individual steps used to effectively perform this measurement with the R&S FSH3-TV. The operating steps are based on the settings of the "Measuring the Video-Signal-to-Noise Ratio" measurement example.

An analog TV test transmitter such as the TV Test Transmitter R&S SFM is used as a signal source together with the CCVS + Component Generator R&S SAF.

### Measurement setup:

Connect the R&S SAF video output to the R&S SFM video input, and the RF output of the analog TV test transmitter to the R&S FSH3-TV RF input.

Settings on the video signal generator:

Standard	PAL, 625 lines
CCIR 17	line 17
CCIR 330	line 330

Settings on the analog TV test transmitter:

Standard	B/G, FM-IRT-A2 dual-channel sound
Group delay	general
Frequency	210.25 MHz
Level	-20 dBm

### Activating the vision carrier modulation measurement:

- Press the MEAS key until the ANALOG TV RECEIVER main menu pops up.
- Press the SELECT MEASURE softkey.
- Select VISION MODULATION from the selection box using the rotary knob or the cursor keys and press the ENTER key.

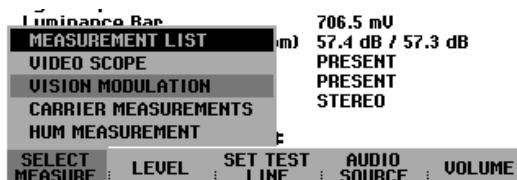

The measurement screen for determining the vision carrier modulation depth is displayed.

*Note:* In the Vision Modulation mode, the demodulated video signal is not present at the multifunction BNC connector.

**Setting the reference level:**

Depending on the selected reference level, the R&S FSH3-TV provides the attenuator at the RF input. The reference level is set manually in the AMPT menu.

To simplify operation, the R&S FSH3-TV offers the automatic LEVEL ADJUST routine.

- Press the MEAS key.
- Press the LEVEL softkey.
- Select LEVEL ADJUST from the selection box using the rotary knob or the cursor keys and press the ENTER key.

The R&S FSH3-TV sets the optimum reference level for this measurement.

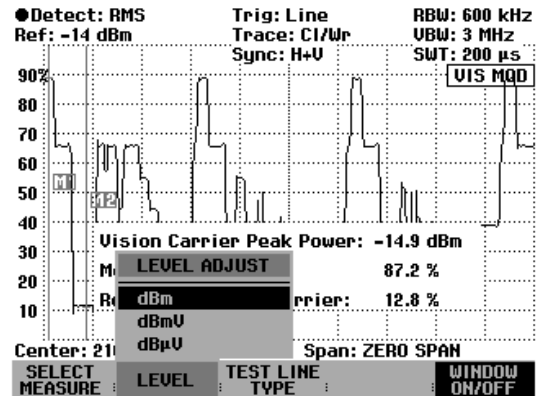

**Setting the measurement line:**

In the default setting, the modulation depth is measured in line 17. The measurement can be performed in any line.

- Press the SWEEP key.
- Press the TRIGGER softkey.
- Select LINE... from the selection box using the rotary knob or the cursor keys and press the ENTER key.

The R&S FSH3-TV opens the entry field for setting video line numbers.

- Using the numeric keypad, enter 330 and confirm the entry with the ENTER key.

The R&S FSH3-TV triggers to line 330 and displays the power distribution of the vision carrier on a linear scale.

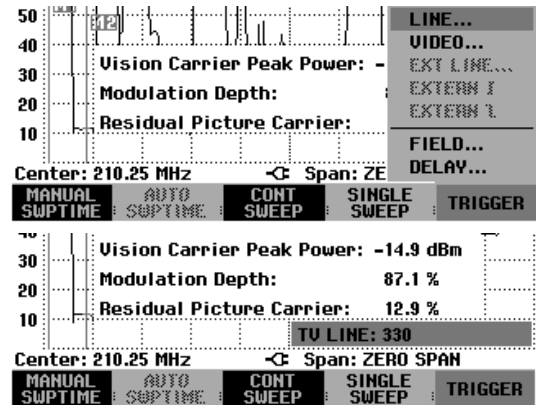



**Setting the markers:**

In the default setting, the marker positions match the test line type that is set in the Measurement List. The markers can be shifted to any position. Using RESET MARKERS, the markers are reset to the default position.

- Press the MARKER key.
- Press the SYNC MARKER softkey.
- Using the rotary knob, shift the marker approximately to the center of the sync pulse.
- Press the WHITE MARKER softkey.
- Using the rotary knob, shift the marker approximately to the center of the white reference bar.

The R&S FSH3-TV displays the measured peak power, the modulation depth and the residual carrier of the vision carrier in the measurement screen.

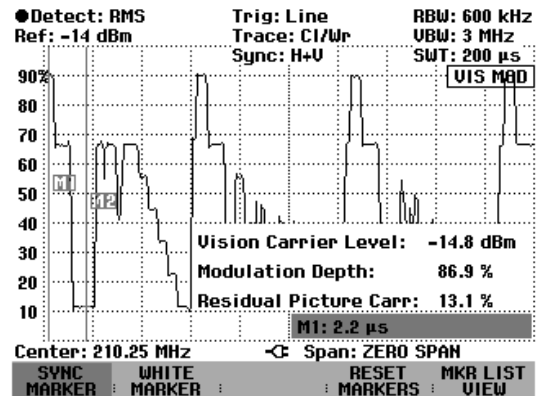

**Setting the trace averaging:**

You can average the trace, which is advisable for noisy signals.

- Press the TRACE key.
- Press the TRACE MODE softkey.
- Select AVERAGE from the selection box using the rotary knob or the cursor keys and press the ENTER key.

The R&S FSH3-TV opens the entry field for setting the averaging factor.

- Using the numeric keypad, enter 10 and confirm the entry with the ENTER key.

The R&S FSH3-TV averages the last ten traces. The current and the selected averaging factor are displayed at the lower right of the measurement screen.

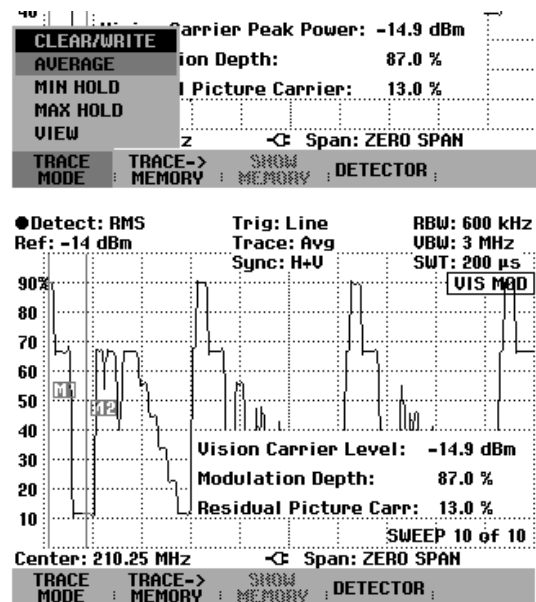

The measurement window conceals part of the trace. Using the WINDOW ON/OFF softkey in the MEAS menu, the measurement window can be blanked.

## Measuring the Carrier Levels and Carrier Frequencies

Use the Carrier Measurements mode to determine the carrier levels and carrier frequencies of analog TV signals. The R&S FSH3-TV measures the power and the levels of the vision and sound carriers and displays the measurement results in a parameter list.

In the following measurement example, a standard K analog TV signal with two FM sound carriers is measured. The example explains the individual steps used to effectively perform this measurement with the R&S FSH3-TV.

The operating steps described are based on the analyzer's default setting.

An analog TV test transmitter such as the TV Test Transmitter R&S SFM is used as a signal source together with the CCVS + Component Generator R&S SAF.

### Measurement setup:

Connect the R&S SAF video output to the R&S SFM video input, and the RF output of the analog TV test transmitter to the R&S FSH3-TV RF input.

Settings on the analog TV test transmitter:

Standard	D/K, 1st FM sound carrier 6.500 MHz, 2nd FM sound carrier 6.258 MHz
Group delay	OIRT
Frequency	519.25 MHz
Level	-20 dBm

### Activating the Carrier Measurements mode of analog TV signals:

- Press the MEAS key.
- Press the MEASURE softkey.
- Select ANALOG TV RECEIVER from the selection box using the rotary knob or the cursor keys and press the ENTER key.

The menu for selecting the analog TV measurement function opens.

- Select CARRIER MEASUREMENTS from the selection box using the rotary knob or the cursor keys and press the ENTER key.

The measurement screen of the carrier levels and carrier frequencies is displayed.

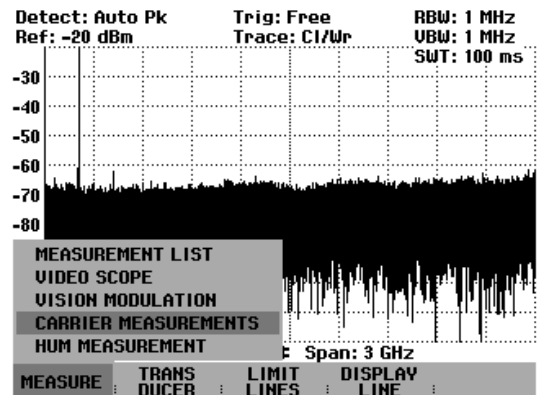

*Note:* In the Carrier Measurements mode, the demodulated video signal is not present at the multifunction BNC connector.

**Setting the analog TV standard:**

- Press the SETUP key.
- Press the LOCAL SETTINGS softkey.
- Select ANALOG TV STANDARD... from the selection box using the rotary knob or the cursor keys and press the ENTER key.
- Select D/K... from the selection box using the rotary knob or the cursor keys and press the ENTER key.
- Select OIRT... from the selection box using the rotary knob or the cursor keys and press the ENTER key.
- Select FM 6.5/FM 6.258... from the selection box using the rotary knob or the cursor keys and press the ENTER key.

The R&S FSH3-TV adjusts the analog TV receiver to the D/K standard using the OIRT group delay pre-correction and the FM sound transmission system in accordance with IRT A2 with the intercarrier frequencies 6.5 MHz for the first sound carrier, and 6.258 MHz for the second sound carrier.

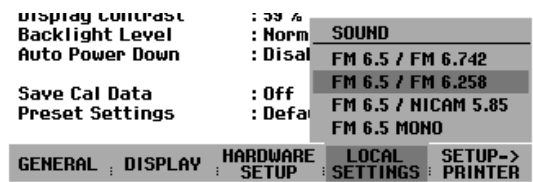
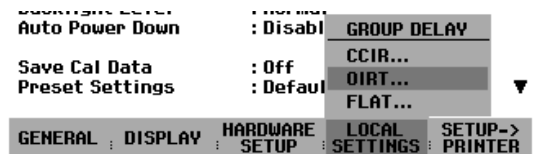
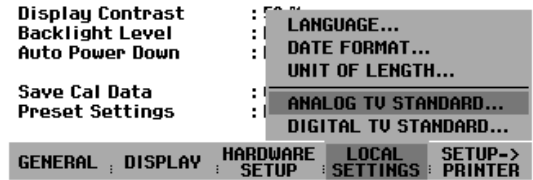

**Setting the receive frequency:**

You can enter the channel center frequency, the vision carrier frequency or the channel number. In the measurement example, the vision carrier frequency is entered.

- Press the FREQ key.
- Press the VISION CARRIER softkey.
- Using the numeric keypad, enter 210.25 and confirm the entry with the MHz key.

The R&S FSH3-TV sets the receive frequency to a vision carrier frequency of 210.25 MHz.



**Setting the reference level:**

The reference level can be set manually in the AMPT menu or automatically in the MEAS/LEVEL menu. The LEVEL ADJUST function is used in the measurement example.

- Press the MEAS key.
- Press the LEVEL softkey.
- Select LEVEL ADJUST from the selection box using the rotary knob or the cursor keys and press the ENTER key.

The R&S FSH3-TV sets the optimum reference level for the carrier measurement.

**Measurement screen containing the carrier levels and carrier frequencies:**

The R&S FSH3-TV measures the level of the vision carrier and its frequency deviation from the set vision carrier frequency, the ratios of vision carrier level to sound carrier levels as well as the sound carrier frequencies referenced to the vision carrier. In addition to the measured values, the R&S FSH3-TV displays the most important settings on the measurement screen.

TU ANALYZER - ANALOG TV	
TV Std. - Group Delay	D/K - OIRT
Sound Standard	FM 6.5 / FM 6.258
Vision Carrier Frequency	519.25 MHz
Channel	27
Reference Level	-20 dBm

Vision Carrier Level	-20.7 dBm
Vision Carrier Frequency Offset	-3434 Hz
Vision/FM Carrier 1 Power Ratio	13.8 dB
Vision/FM Carrier 1 Freq Offset	6500001 Hz
Vision/FM Carrier 2 Power Ratio	20.9 dB
Vision/FM Carrier 2 Freq Offset	6258001 Hz

SELECT MEASURE	LEVEL ADJUST	LEVEL UNIT	:	:
:	:	:	:	:

**Measuring the Hum Modulation**

To determine the hum modulation of analog TV signals, the R&S FSH3-TV provides the Hum Measurement mode. The R&S FSH3-TV calculates the hum modulation ratio in accordance with the EN 50083 standard. The R&S FSH3-TV must be tuned to the vision carrier. The vision carrier is filtered with a bandwidth of 600 kHz. This ensures that sound carriers and color subcarriers are suppressed and that the sync pulses are transmitted without any power degradation. The filtered vision carrier signal is sampled at the time of the sync pulse. As a result, the video information is removed from the measurement signal. The trace shows the sync pulse amplitude values of the vision carrier.

In the following measurement example, the hum modulation is measured. The example explains the individual steps used to effectively perform this measurement with the R&S FSH3-TV. The operating steps are based on the settings of the "Measuring the Video-Signal-to-Noise Ratio" measurement example.

An analog TV test transmitter such as the TV Test Transmitter R&S SFM is used as a signal source together with the CCVS + Component Generator R&S SAF. The video generator signal is superimposed by a 50 Hz hum signal.

**Activating the Hum Measurement mode:**

- Press the MEAS key until the ANALOG TV RECEIVER main menu pops up.
- Press the SELECT MEASURE softkey.
- Select HUM MEASUREMENT from the selection box using the rotary knob or the cursor keys and press the ENTER key.

MEASUREMENT LIST	53.4 dB / 52.9 dB			
VIDEO SCOPE	PRESENT			
VISION MODULATION	PRESENT			
CARRIER MEASUREMENTS	STEREO			
HUM MEASUREMENT				
SELECT MEASURE	LEVEL	SET TEST LINE	AUDIO SOURCE	VOLUME

The R&S FSH3-TV is set in accordance with the hum measurement.

*Note: In the Hum Measurement mode, the demodulated video signal is not present at the multifunction BNC connector.*

**Setting the reference level:**

As a result of the hum modulation, the trace may be above the upper edge of the measurement screen. In this case, shift the trace by means of the reference level setting. The R&S FSH3-TV provides an automatic routine to simplify this procedure.

- Press the MEAS key until the hum modulation menu bar pops up.
- Press the LEVEL ADJUST softkey.

The R&S FSH3-TV sets the optimum reference level for this measurement.

The R&S FSH3-TV displays the hum modulation trace on the measurement screen. The hum modulation ratio in accordance with the EN 50083 standard is displayed in the lower half of the measurement screen.

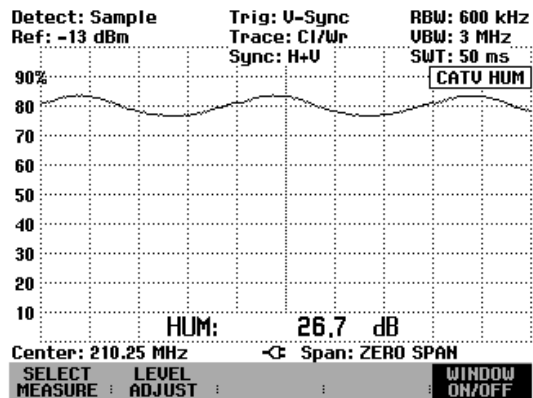
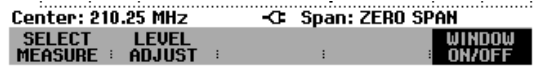

## Measurements on Digital TV Signals

(only available with the R&S FSHTV-K21 or R&S FSHTV-K22 software option)

### Measuring the Transmission Parameters

The main transmission parameters of digital TV signals include carrier frequency, channel power, modulation error and bit error ratio. The following measurement example shows the individual steps used to effectively determine these parameters with the R&S FSH3-TV.

A digital TV test transmitter such as the TV Test Transmitter R&S SFQ is used as a signal source.

#### Measurement setup:

Connect the RF output of the digital TV test transmitter to the R&S FSH3-TV RF input.

Settings on the digital TV test transmitter:

Standard	DVB-C in accordance with J.83/B
QAM order	256
Symbol rate	5.360537 Msymb/s
Frequency	394.000 MHz
Level	-15 dBm

Set the R&S FSH3-TV to its default settings to show all the operating steps that are required.

➤ Press the PRESET key.

The analyzer displays the frequency spectrum from 100 kHz to 3 GHz – the R&S FSH3-TV's entire frequency span. At 394 MHz, the generator signal is displayed as a vertical line. Generator harmonics can also be seen as lines at frequencies that are multiples of 394 MHz.

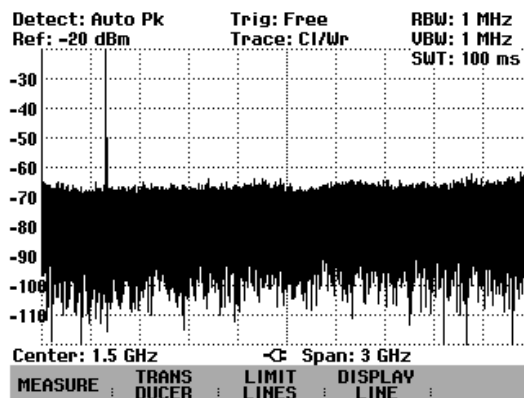

**Activating the digital TV receiver:**

Activate the digital TV receiver of the R&S FSH3-TV for measuring the transmission parameters.

- Press the MEAS key.
- Press the MEASURE softkey.
- Select MEASUREMENT LIST from the selection box using the rotary knob or the cursor keys and press the ENTER key.

The R&S FSH3-TV activates the digital TV receiver. The result list is displayed, providing an overview of the default setting and the quality of the received TV signal.

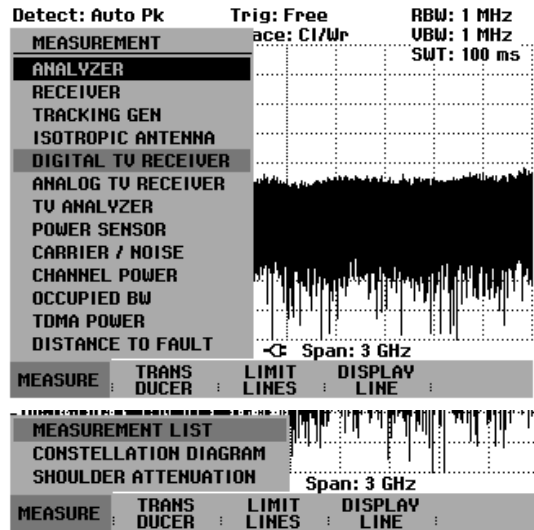

**Setting the digital TV standard:**

- Press the SETUP key.
- Press the LOCAL SETTINGS softkey.
- Select DIGITAL TV STANDARD... from the selection box using the rotary knob or the cursor keys and press the ENTER key.
- Select QAM/J.83/B – US CABLE from the selection box using the rotary knob or the cursor keys and press the ENTER key.

The R&S FSH3-TV adjusts the digital TV receiver to the QAM standard in accordance with J.83/B.

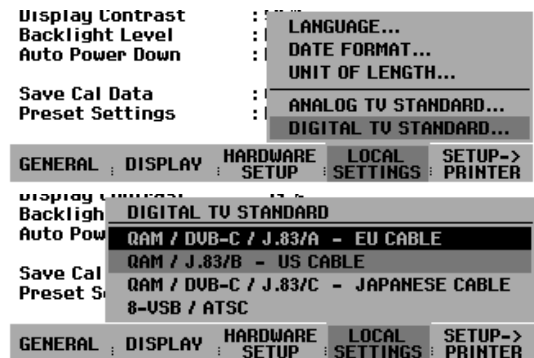

**Setting the receive frequency:**

- Press the FREQ key.

The R&S FSH3-TV opens the entry field for setting the carrier frequency.

- Using the numeric keypad, enter 394 and confirm the entry with the MHz key.

The R&S FSH3-TV sets the receive frequency to a carrier frequency of 394.000000 MHz.



**Setting the QAM order:**

- Press the BW key.
- Press the QAM ORDER softkey.
- Select 256 from the selection box using the rotary knob or the cursor keys and press the ENTER key.

The R&S FSH3-TV sets the demodulator to the QAM order 256. In accordance with the J.83/B standard, it sets the symbol rate to 5.360537 MHz and the roll-off factor to 0.12.

*Note: With J.83/B 64QAM, the R&S FSH3-TV sets the symbol rate to 5.056941 MHz and the roll-off factor to 0.18.*

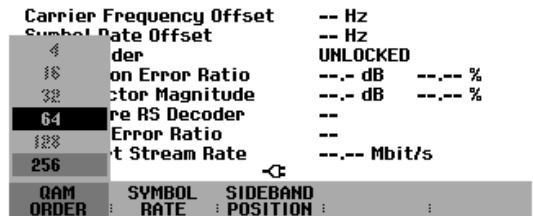

**Setting the symbol rate:**

The symbol rate need not be set in the measurement example.

The R&S FSH3-TV automatically sets the standard symbol rate. For QAM, the symbol rate can vary between 2.000000 MHz and 6.999000 MHz.

- Press the BW key.
- Press the SYMBOL RATE softkey.
- Using the numeric keypad, enter the symbol rate you need and terminate the entry with the appropriate unit key.

**Setting the RF attenuator:**

Depending on the selected reference level, the R&S FSH3-TV provides the attenuator at the RF input. It offers two modes, the LOW NOISE mode for maximum sensitivity and the LOW DISTORTION mode for the lowest possible intermodulation products. The two modes differ in that the R&S FSH3-TV sets an RF attenuator attenuation that is 10 dB higher for LOW DISTORTION than it is for LOW NOISE.

- Press the SETUP key.
- Press the HARDWARE SETUP softkey.
- Select DYNAMIC RANGE from the selection box using the rotary knob or the cursor keys and press the ENTER key.
- Select the mode you need using the rotary knob or the cursor keys and press the ENTER key.

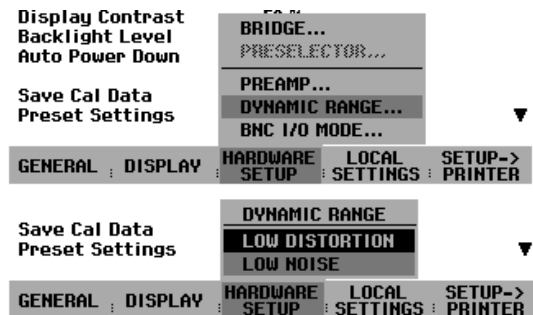

The reference level is set manually in the AMPT menu.

- Press the AMPT key.

The R&S FSH3-TV opens the entry field for setting the reference level. You can change the reference level using the rotary knob or the cursor keys, or you can enter a new value using the numeric keypad.

Der aktuell eingestellte Referenzpegel wird im Messbildschirm angezeigt. Als Einstellhilfe wird in Klammern hinter dem Einstellwert die Differenz zum idealen Demodulatorpegel angezeigt.



**Setting the reference level unit:**

The reference level can be entered in dBm, dBµV, dBmV, V or W.

- Press the AMPT key.
- Press the UNIT softkey.
- Select the unit you want using the rotary knob or the cursor keys, and press the ENTER key or the UNIT softkey.

The reference level can now be set in the selected unit.

- Press the REF LEVEL softkey.

The R&S FSH3-TV opens the entry field for setting the reference level. You can change the reference level using the rotary knob or the cursor keys, or you can enter a new value using the numeric keypad.

**Automatic routine for setting the optimum reference level:**

To simplify operation and to avoid wrong settings, the R&S FSH3-TV is equipped with an automatic routine for setting the optimum reference level.

- Press the MEAS key until the DIGITAL TV RECEIVER menu pops up (toggle key).
- Press the LEVEL softkey.
- Select LEVEL ADJUST from the selection box using the rotary knob or the cursor keys and press the ENTER key.

The R&S FSH3-TV sets the optimum reference level. In the Measurement List and Constellation Diagram modes, the modulation error of the demodulated QAM signal is the setting criterion of the Level Adjust function.

**Measurement screen:**

The result list shows the main instrument settings and the transmission parameters of the received digital TV signal.

10000 symbols are processed to calculate the modulation error and the vector error. A clock symbol to the right of the parameter name indicates that so far less than 10000 symbols have been processed for the calculation.

DIGITAL TV RECEIVER			
Standard QAM / J.83/B - US CABLE			
Center Frequency	394.00000 MHz		
Channel	--		
Modulation	256-QAM		
Symbol Rate	5.360537 MHz		
Reference Level	-14 dBm	(0 dB)	
<hr/>			
Power	-15.1 dBm		
Carrier Frequency Offset	-193 Hz		
Symbol Rate Offset	-21 Hz		
FEC Decoder	LOCKED		
Modulation Error Ratio	37.5 dB	1.34 %	
Error Vector Magnitude	41.7 dB	0.82 %	
BER before RS Decoder	0.0E0	(199 / 1 k)	
Segment Error Ratio	0.0E0	(463 / 1 k)	
Transport Stream Rate	38.810548 Mbit/s		
⏪			
SELECT MEASURE :	LEVEL ADJUST :	PWR UNIT :	RESTART MEASURE :

## I/Q Constellation Display

The R&S FSH3-TV displays the complex baseband signal for the sampling times in the Cartesian coordinates system, the I/Q constellation diagram.

The following measurement example shows the individual steps used to effectively perform this measurement with the R&S FSH3-TV.

The operating steps are based on the settings of the "Measuring the Transmission Parameters" measurement example.

A digital TV test transmitter such as the TV Test Transmitter R&S SFQ is used as a signal source.

### Measurement setup:

Connect the RF output of the digital TV test transmitter to the R&S FSH3-TV RF input.

Settings on the digital TV test transmitter:

Standard	DVB-C in accordance with J.83/B
QAM order	256
Symbol rate	5.360537 Msymb/s
Frequency	394.000 MHz
Level	-15 dBm

### Activating the constellation diagram:

- Press the MEAS key until the DIGITAL TV RECEIVER menu pops up (toggle key).
- Press the SELECT MEASURE softkey.
- Select CONSTELLATION DIAGRAM from the selection box using the rotary knob or the cursor keys and press the ENTER key.

The R&S FSH3-TV displays the currently demodulated I/Q symbols. In the default setting, 10000 symbols are used. The constellation data is updated at a clock rate of 1000 symbols. A clock symbol is displayed below the constellation diagram until the requested number of symbols can be displayed.

In addition to the constellation diagram, the parameters of the measurement parameter list are displayed.

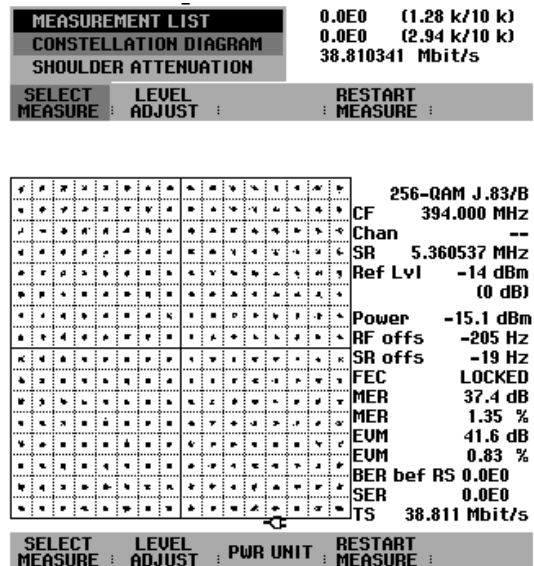

**Setting the display parameters:**

In the CONT display mode, the constellation data is continuously updated. The number of the symbols displayed can be set from 1000 to 1000000 symbols in 1000 symbols steps. If there is no synchronization to the receive signals, 1000 symbols are displayed. CONT is the default setting.

In the measurement example, the constellation data is integrated infinitely.

- Press the TRACE key.
- Press the HOLD softkey.

As long as the demodulator is synchronized to the receive signal, the constellation data is integrated.

To calculate the modulation error and the vector error, the last 10000 symbols are used.

To calculate the bit error ratio as well as the segment and packet error ratios, all results since the last FEC synchronization are used.

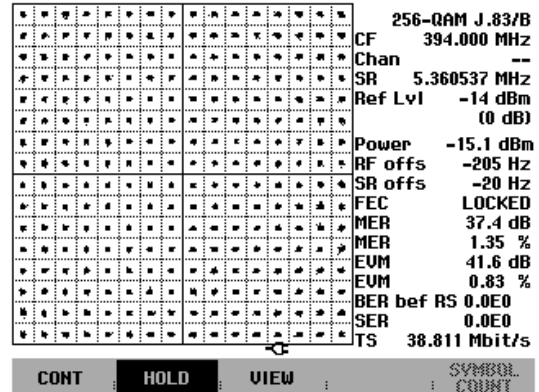

**Measuring the Shoulder Attenuation of a QAM Signal**

The R&S FSH3-TV measures the shoulder attenuation of the received digital TV signal. With the QAM standards, it performs shoulder attenuation measurements in accordance with the ETSI TR 101 290 standard. The following measurement example shows the individual steps used to effectively measure the shoulder attenuation with the R&S FSH3-TV.

The operating steps are based on the settings of the "Measuring the Transmission Parameters" measurement example.

A digital TV test transmitter such as the TV Test Transmitter R&S SFQ is used as a signal source.

**Measurement setup:**

Connect the RF output of the digital TV test transmitter to the R&S FSH3-TV RF input.

Settings on the digital TV test transmitter:

Standard	DVB-C in accordance with J.83/B
QAM order	256
Symbol rate	5.360537 Msymb/s
Frequency	394.000 MHz
Level	-15 dBm

**Activating the shoulder attenuation measurement:**

- Press the MEAS key until the DIGITAL TV RECEIVER menu pops up (toggle key).
- Press the SELECT MEASURE softkey.
- Select SHOULDER ATTENUATION from the selection box using the rotary knob or the cursor keys and press the ENTER key.



The R&S FSH3-TV switches to the SHOULDER ATTENUATION measurement screen.

*Note:* In the SHOULDER ATTENUATION mode, the TS-ASI signal is not present at the multifunction BNC connector.

**Setting the reference level:**

The reference level is set manually in the AMPT menu. To simplify operation and to avoid wrong settings, the R&S FSH3-TV is equipped with an automatic routine for setting the optimum reference level. The setting criterion in the shoulder attenuation measurement is the measured ideal shoulder attenuation value. The routine can be applied either to the lower or the upper shoulder.

- Press the MEAS key until the DIGITAL TV RECEIVER menu pops up (toggle key).
- Press the LEVEL softkey.
- Select LEVEL ADJUST UPPER SHOULDER or LEVEL ADJUST LOWER SHOULDER from the selection box using the rotary knob or the cursor keys and press the ENTER key.

**Measurement screen:**

The measurement screen displays the spectrum of the digital TV signal. The measurement parameters channel power as well as upper and lower shoulder attenuation are indicated at the lower half of the screen. Light blue frequency lines mark the frequency ranges where the shoulder attenuation values are measured.

With the 8-VSB/ATSC standard, the frequency marker "C" is additionally set to the pilot carrier. Frequency and level of the pilot carrier are displayed at the upper left of the screen.

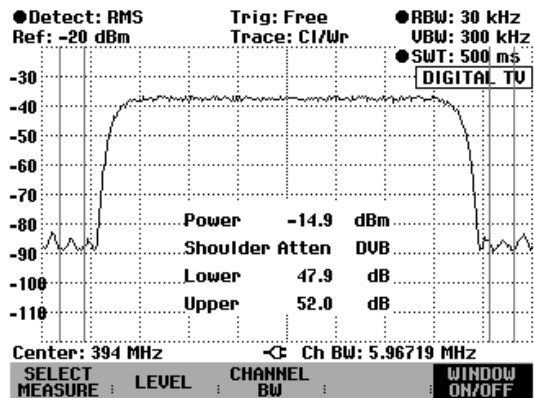

## Measuring the Shoulder Attenuation of an 8-VSB/ATSC Signal

The R&S FSH3-TV measures the shoulder attenuation of the received digital TV signal. In the case of the 8-VSB/ATSC standard, it performs measurements in accordance with the FCC recommendation. The following measurement example shows the individual steps used to effectively measure the shoulder attenuation with the R&S FSH3-TV.

The operating steps are based on the settings of the "Measuring the Transmission Parameters" measurement example.

A digital TV test transmitter such as the TV Test Transmitter R&S SFQ is used as a signal source.

### Measurement setup:

Connect the RF output of the digital TV test transmitter to the R&S FSH3-TV RF input.

Settings on the digital TV test transmitter:

Standard	8-VSB in accordance with ATSC
Symbol rate	10.672238 Msymb/s
Pilot frequency	391.309441 MHz
Level	-15 dBm

### Setting the digital TV standard:

To perform the shoulder attenuation measurement in accordance with the ATSC recommendation, set the 8-VSB/ATSC standard.

- Press the SETUP key.
- Press the LOCAL SETTINGS softkey.
- Select DIGITAL TV STANDARD... from the selection box using the rotary knob or the cursor keys and press the ENTER key.
- Select 8-VSB/ATSC from the selection box using the rotary knob or the cursor keys and press the ENTER key.

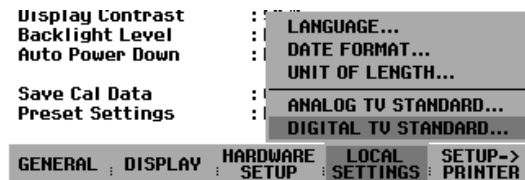

### Activating the shoulder attenuation measurement:

- Press the MEAS key until the DIGITAL TV RECEIVER menu pops up (toggle key).
- Press the SELECT MEASURE softkey.
- Select SHOULDER ATTENUATION from the SELECTION box using the rotary knob or the cursor keys and press the ENTER key.



The R&S FSH3-TV switches to the SHOULDER ATTENUATION measurement screen.

**Setting the reference level:**

The reference level is set manually in the AMPT menu. To simplify operation and to avoid wrong settings, the R&S FSH3-TV is equipped with an automatic routine for setting the optimum reference level. The setting criterion for the shoulder attenuation measurement is the measured ideal shoulder attenuation value. The routine can be applied to either the lower or the upper shoulder.

- Press the MEAS key until the DIGITAL TV RECEIVER menu pops up (toggle key).
- Press the LEVEL softkey.
- Select LEVEL ADJUST UPPER SHOULDER or LEVEL ADJUST LOWER SHOULDER from the selection box using the rotary knob or the cursor keys and press the ENTER key.

**Measurement screen:**

The measurement screen displays the spectrum of the digital TV signal. The measurement parameters channel power as well as upper and lower shoulder attenuation are indicated at the lower half of the screen. Light blue frequency lines mark the frequency ranges where the shoulder attenuation values are measured.

The frequency marker 'C' is set to the pilot carrier. Frequency and level of the pilot carrier are displayed at the upper left of the screen.

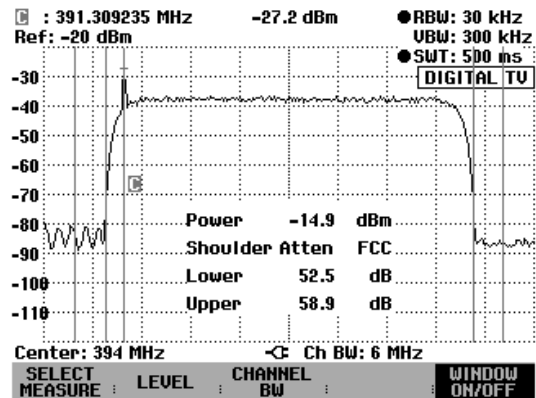

## Measuring the Shoulder Attenuation of a DVB-T Signal in Accordance with ETSI TR 101 290

The R&S FSH3-TV measures the shoulder attenuation of any signals where power is equally distributed, e.g. DVB-T signals. The following measurement example shows the individual steps used to effectively measure the shoulder attenuation of a DVB-T signal with the R&S FSH3-TV.

A digital TV test transmitter such as the TV Test Transmitter R&S SFQ is used as a signal source.

### Measurement setup:

Connect the RF output of the digital TV test transmitter to the R&S FSH3-TV RF input.

Settings on the digital TV test transmitter:

Standard	DVB-T
Mode	8 k
Frequency	650.000 MHz
Level	-15 dBm

Set the R&S FSH3-TV to its default settings to show all the operating steps that are required.

- Press the PRESET key.

The analyzer displays the frequency spectrum from 100 kHz to 3 GHz – the R&S FSH3-TV's entire frequency span. At 650 MHz, the generator signal is displayed as a vertical line. Generator harmonics can also be seen as lines at frequencies that are multiples of 650 MHz.

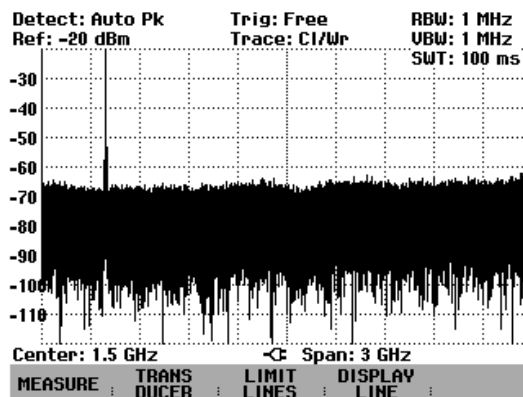

### Activating the shoulder attenuation measurement:

Activate the Shoulder Attenuation mode of the digital TV receiver to measure the shoulder attenuation.

- Press the MEAS key.
- Press the MEASURE softkey.
- Select DIGITAL TV RECEIVER from the selection box using the rotary knob or the cursor keys and press the ENTER key.

The R&S FSH3-TV opens the menu for selecting the measurement mode.

- Select SHOULDER ATTENUATION from the selection box using the rotary knob or the cursor keys and press the ENTER key.

The R&S FSH3-TV activates the shoulder attenuation measurement.

**Setting the digital TV standard:**

To ensure that the shoulder attenuation is measured in accordance with ETSI TR 101 290, one of the QAM standards needs to be set, e.g. DVB-C in accordance with J.83/A.

- Press the SETUP key.
- Press the LOCAL SETTINGS softkey.
- Select DIGITAL TV STANDARD... from the selection box using the rotary knob or the cursor keys and press the ENTER key.

Select QAM/DVB-C/J.83/A – EU CABLE from the selection box using the rotary knob or the cursor keys and press the ENTER key.

**Setting the receive frequency:**

- Press the FREQ key.

The R&S FSH3-TV opens the entry field for setting the carrier frequency.

- Using the numeric keypad, enter 650 and confirm the entry with the MHz key.

The R&S FSH3-TV sets the receive frequency to a carrier frequency of 650.000000 MHz.

**Setting the channel bandwidth:**

In the default setting, the R&S FSH3-TV automatically sets the channel bandwidth. It calculates the channel bandwidth from the standard-dependent roll-off factor and the set symbol rate. The following formula applies to the QAM standards:

$$\text{Channel bandwidth} = \text{symbol rate} * (1 + \text{roll-off factor})$$

For the 8-VSB/ATSC standard, the channel bandwidth is preset to 6 MHz.

You can also set the channel bandwidth manually instead of using the automatic setting. This allows you to measure also the shoulder attenuation values of carrier signals where the power is equally distributed, e.g. DVB-T signals.

- Press the MEAS key until the DIGITAL TV RECEIVER menu pops up (toggle key).
- Press the CHANNEL BW softkey.
- Using the rotary knob or the cursor keys, select MANUAL... and confirm your choice with the ENTER key or the CHANNEL BW softkey.

The R&S FSH3-TV opens the entry field for setting the channel bandwidth.

- Using the numeric keypad, enter 8 and confirm the entry with the MHz key.

The R&S FSH3-TV sets the frequency span and the measurement bandwidth in accordance with a channel bandwidth of 8 MHz.

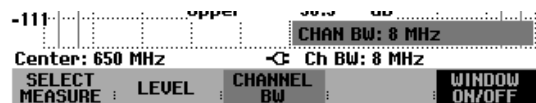
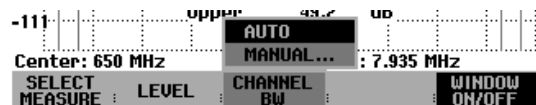



**Setting the reference level:**

The reference level is set manually in the AMPT menu. To simplify operation and to avoid wrong settings, the R&S FSH3-TV is equipped with an automatic routine for setting the optimum reference level.

In the Shoulder Attenuation mode, the LEVEL ADJUST function measures the shoulder attenuation depending on the reference level, and sets the reference level where the shoulder attenuation is highest. This ensures that the receiver is optimally set, irrespective of the channels and levels of the input signal. Both upper and lower shoulder attenuation are measurement criteria. In the measurement example, the lower shoulder attenuation will be the criterion.

- Press the MEAS key until the DIGITAL TV RECEIVER menu pops up (toggle key).
- Press the LEVEL softkey.
- Using the rotary knob or the cursor keys, select LOWER ADJUST LOWER SHOULDER and confirm your choice with the ENTER key or the LEVEL ADJUST softkey.

The reference level is set where the lower shoulder attenuation is highest.

**Measurement screen:**

The R&S FSH3-TV displays the DVB-T signal spectrum. The frequency span is set to 1.2 times the channel bandwidth and can be set to maximally 10 times the channel bandwidth.

The measurement parameters channel power as well as upper and lower shoulder attenuation are indicated in the lower half of the measurement screen. Using the WINDOW ON/OFF softkey, you can blank the parameters.

Light blue frequency lines mark the frequency ranges in which the shoulder attenuation values are measured.

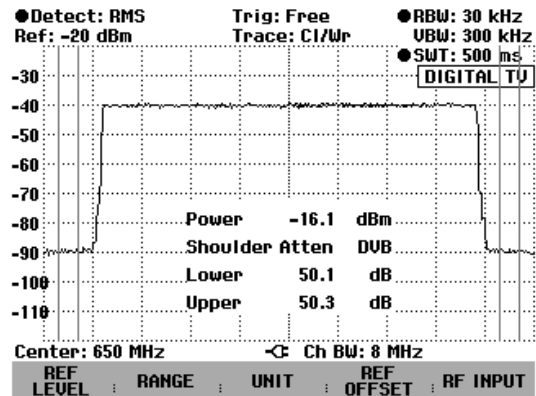

# Measuring the Carrier-to-Noise Ratio

(Available as of firmware version 8.0 or later.)

The R&S FSH3-TV offers a carrier/noise measurement for measuring the ratio of carrier power to noise power. It performs the measurement in two steps. First, the carrier power of a transmission channel is measured or a reference power determined which is then used for C/N calculation. In the second step, the R&S FSH3-TV measures the noise power of an unoccupied transmission channel and calculates the ratio of carrier power to noise power.

## Determining the carrier power (reference power or reference level):

The R&S FSH3-TV offers the carrier power measurement for three different types of modulation.

- Digital Tx  
In the Digital Tx operating mode, the channel power of a reference channel is measured. This is common with digitally modulated carriers where power is equally distributed, i.e. the carrier power is independent of the modulation signal.
- Analog TV  
In the Analog TV operating mode, the peak power of the vision carrier is measured. This is common with amplitude-modulated TV signals.
- CW Tx  
In the CW Tx operating mode, the power of an unmodulated carrier is measured.
- Manual entry of a reference power or a reference level  
You can also enter a reference power or reference level manually. The R&S FSH3-TV then uses this value for C/N calculation.

## Noise power and C/N power ratio:

For noise power measurements, the R&S FSH3-TV is set to an unoccupied transmission channel where it measures the noise power in accordance with the selected channel bandwidth. If required, the R&S FSH3-TV also displays the power ratio with reference to the noise power density of the transmission channel ( $C/N_0$ ).  $C/N_0 = C/N + 10 \lg(\text{channel bandwidth/Hz})$

## Activating the C/N measurement:

- Press the MEAS key.
- Press the MEASURE softkey.

The menu for measurement functions opens.

- Using the rotary knob or the cursor keys, select CARRIER / NOISE from the menu and confirm your choice with the ENTER key or the MEASURE softkey.

The R&S FSH3-TV activates the carrier/noise mode and starts the carrier power measurement that was selected last.

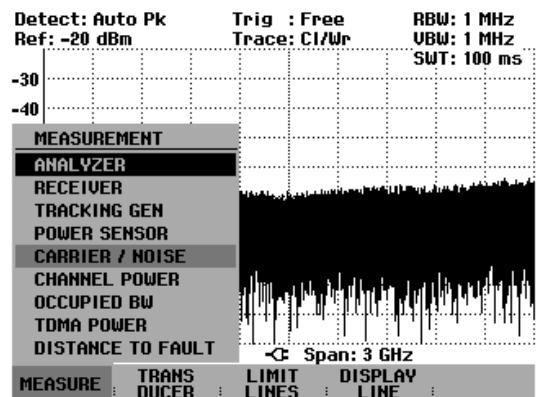

The major measurement parameter settings are available directly in the main menu of the carrier/noise measurement or can be entered using the appropriate keys.

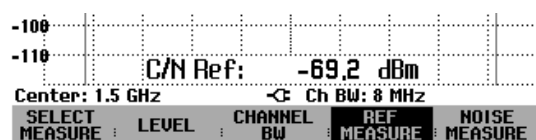

## Reference power/reference level

To determine the reference, you need to enter the type of reference measurement, the reference channel and the channel bandwidth of the reference channel.

### Selecting the reference measurement:

- Press the SELECT MEASURE softkey.
- Using the rotary knob or the cursor keys, select the desired measurement method to determine the reference carrier power (Digital Tx, Analog TV or CW Tx) and confirm your choice with the ENTER key or the SELECT MEASURE softkey.

The R&S FSH3-TV measures the reference in accordance with the selected modulation method.

### Selecting the reference channel:

- Press the REF MEASURE softkey.
- Using the rotary knob or the cursor keys, select the desired entry (Channel, Vision Carrier Freq, Center Freq or 8VSB Pilot Freq) and confirm your choice with the ENTER key or the F4 softkey.

You can alternatively also enter the channel center frequency after pressing the FREQ function key.

The R&S FSH3-TV measures the reference in the selected transmission channel.

### Entering the channel bandwidth of the reference channel:

- If the reference measurement is active, press the CHANNEL BW softkey.
- Enter the desired value and terminate the entry with the appropriate unit key.

The R&S FSH3-TV sets the span in accordance with the selected bandwidth.

The channel center frequency is calculated when the vision carrier frequency is entered.

### Selecting the reference unit:

- Press the LEVEL softkey.
- Using the rotary knob or the cursor keys, select the desired entry (dBm, dBmV or dB $\mu$ V) and confirm your choice with the ENTER key or the F2 softkey.

The measurement result of the reference measurement is displayed in the selected unit.

### Manual reference entry:

- Press the REF MEASURE softkey.
- Using the rotary knob or the cursor keys, select MAN REF POWER/LEVEL and confirm with the ENTER key or the REF MEASURE softkey.
- Enter the desired reference value in the selected reference unit by means of the numeric keypad and terminate the entry with one of the unit keys.

### Automatic leveling:

- If the reference measurement is active, press the LEVEL softkey.
- Using the rotary knob or the cursor keys, select LEVEL ADJUST and confirm your choice with the ENTER key or the F2 softkey.

Depending on the input signal, the R&S FSH3-TV is optimally levelled.

## Measuring the noise power

Enter an unoccupied transmission channel and its channel bandwidth to determine the noise power.

### Selecting the result display:

- Press the SELECT MEASURE softkey.
- Using the rotary knob or the cursor keys, select the desired result display (C/N or C/N<sub>0</sub>) and confirm your choice with the ENTER key or the F1 softkey.

The R&S FSH3-TV outputs the power ratio according to the selected result display.

### Selecting the unoccupied transmission channel:

- Press the NOISE MEASURE softkey.
- Using the rotary knob or the cursor keys, select the desired entry (Channel, Vision Carrier Freq, Center Freq or 8VSB Pilot Freq) and confirm your choice with the ENTER key or the F5 softkey.

You can alternatively also enter the channel center frequency after pressing the FREQ function key. The R&S FSH3-TV measures the noise power in the selected transmission channel.

### Entering the channel bandwidth of the noise channel:

- If the noise power measurement is active, press the CHANNEL BW softkey.
- Enter the desired value and terminate the entry with the appropriate unit key.

The R&S FSH3-TV sets the span in accordance with the selected bandwidth. The channel center frequency is calculated when the vision carrier frequency is entered.

### Automatic leveling:

- If the noise power measurement is active, press the LEVEL softkey.
- Using the rotary knob or the cursor keys, select LEVEL ADJUST and confirm your choice with the ENTER key or the F2 softkey.

Depending on the input signal, the R&S FSH3-TV is optimally levelled.

### Blanking out the result display:

The C/N ratio or the reference is indicated at the bottom of the display. This insertion can be deactivated.

- Press the NOISE MEASURE or REF MEASURE softkey.
- Using the rotary knob or the cursor keys, select DISPLAY OFF and confirm your choice with the ENTER key or the F4 or F5 softkey.

The R&S FSH3-TV blanks out the result display.

### Inserting the result display:

- Press the NOISE MEASURE or REF MEASURE softkey.
- Using the rotary knob or the cursor keys, select DISPLAY ON and confirm your choice with the ENTER key or the F4 or F5 softkey.

The R&S FSH3-TV inserts the result display at the bottom of the display.

## Measurements on Cable TV Systems

Use the Preselector R&S FSHTV-Z60 to perform measurements on cable TV systems. The preselector is connected ahead of the R&S FSH3-TV and reduces the cable TV spectrum and thus the total power at the first mixer. As a result, the dynamic range is increased.

### Measuring the Composite Triple Beat Ratio

For measuring the ratio of the composite triple beat (CTB) intermodulation products to the carrier power, the R&S FSH3-TV offers the CTB measurement in the CABLE TV menu. It performs the measurement in two steps in accordance with the EN 50083 standard. First, the reference power is measured, or a reference power is determined which is then used to calculate the CTB ratio. In the second step, the R&S FSH3-TV measures the power of the CTB intermodulation products in an unoccupied transmission channel and calculates their ratio to the reference power.

The following measurement example shows the individual steps used to effectively perform this measurement with the R&S FSH3-TV.

For the measurement example to be reproducible, only an analog TV test transmitter such as the TV Test Transmitter R&S SFM together with the CCVS + Component Generator R&S SAF and two signal generators such as the Signal Generator R&S SML are used as signal sources.

#### Measurement setup:

Connect the R&S SAF video output to the R&S SFM video input. Add the RF output signals via a coupler and connect them to the R&S FSH3-TV RF input.

Settings on the video signal generator:

Standard                    PAL, 625 lines

Settings on the analog TV test transmitter:

Standard                    B/G, FM-IRT-A2 dual-channel sound

Group delay                general

Frequency                  210.25 MHz

Level                        -20 dBm

Settings on the first signal generator:

Frequency                  217.25 MHz

Level                        -20 dBm

Settings on the second signal generator:

Frequency                  224.25 MHz

Level                        -20 dBm

The figure at the right shows the spectrum of the described measurement setup.

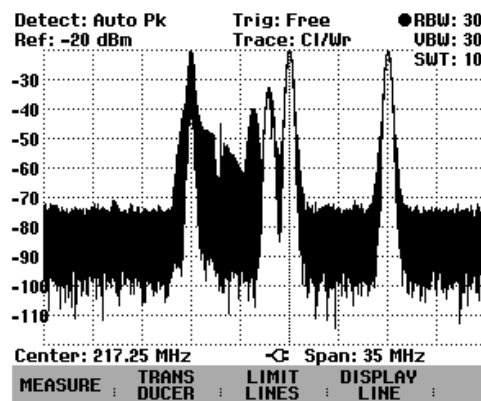

Set the R&S FSH3-TV to its default settings to show all the operating steps that are required.

- Press the PRESET key.

The analyzer displays the frequency spectrum from 100 kHz to 3 GHz – the R&S FSH3-TV’s entire frequency span. With 210.25 MHz, 217.25 MHz and 224.25 MHz, the generator signals are displayed as lines. Generator harmonics can also be seen as lines at frequencies that are multiples of 210.25 MHz, 217.25 MHz and 224.25 MHz.

**Activating the composite triple beat measurement:**

- Press the MEAS key.
- Press the MEASURE softkey.
- Using the cursor keys or the rotary knob, select CABLE TV from the menu and confirm your choice with the ENTER key or the MEASURE softkey.

The R&S FSH3-TV opens the CABLE TV menu.

- Using the rotary knob or the cursor keys, select CTB from the menu and confirm your choice with the ENTER key or the MEASURE softkey.

The R&S FSH3-TV activates the CTB measurement mode and starts the reference carrier measurement.

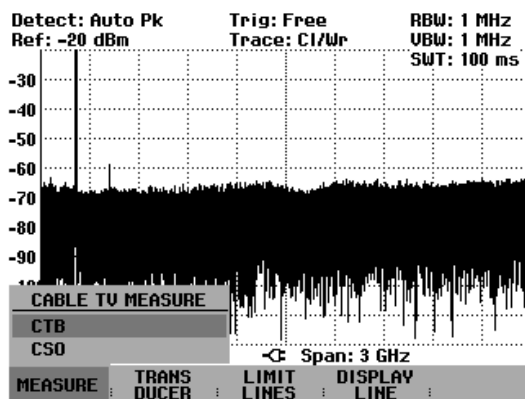

### Measuring the Reference Power

The reference power is either measured in an analog TV channel or can be defined manually. If the vision carriers are modulated negatively, the reference power is the vision carrier power at the time of the sync pulse.

In the example, the reference channel is the analog TV signal with a vision carrier frequency of 210.25 MHz.

- Press the MEAS key.
- Press the REF MEASURE softkey.
- Using the cursor keys or the rotary knob, select VISION CARR FREQ... from the menu and confirm your choice with the ENTER key or the REF MEASURE softkey.

The R&S FSH3-TV opens the entry field for setting the vision carrier frequency.

- Using the numeric keypad, enter 210.25 and confirm the entry with the MHz key.

The R&S FSH3-TV sets the receive frequency to a vision carrier frequency of 210.250000 MHz.

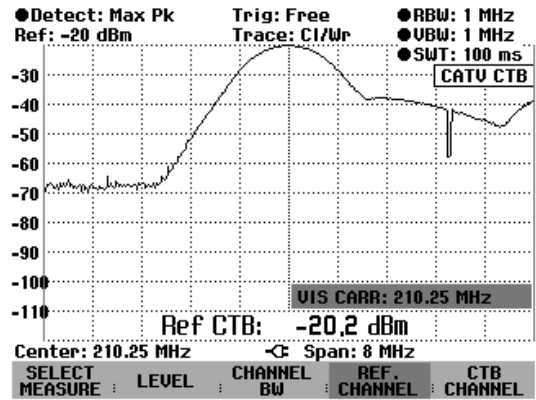

The measurement screen displays the analog TV channel spectrum with a vision carrier frequency of 210.250 MHz. The frequency span corresponds to the channel bandwidth of the analog TV standard set in the SETUP – LOCAL SETTINGS menu.

The channel bandwidth can also be set manually.

- Press the MEAS key.
- Press the CHANNEL BW softkey.

The R&S FSH3-TV opens the entry field for setting the channel bandwidth.

- Using the numeric keypad, enter 7 and confirm the entry with the MHz key.

The R&S FSH3-TV sets the channel bandwidth to 7 MHz.

**Setting the reference level:**

The reference level is set manually in the AMPT menu. To simplify operation and to prevent incorrect measurements, the R&S FSH3-TV has an automatic routine for setting the reference level. During the reference level measurement, the LEVEL ADJUST function measures the maximum receive level and sets the reference level accordingly.

- Press the MEAS key.
- If the reference measurement is active, press the LEVEL softkey.
- Using the rotary knob or the cursor keys, select LEVEL ADJUST and confirm your choice with the ENTER key or the LEVEL softkey.

The measurement screen displays the reference channel spectrum. The measured reference power is displayed in the lower half of the screen. The reference level is output in dBm, dBμV or dBmV.

- Press the MEAS key.
- Press the LEVEL softkey.
- Using the rotary knob or the cursor keys, select the unit you want and confirm your choice with the ENTER key or the LEVEL softkey.

The reference measurement result is displayed in the selected unit.

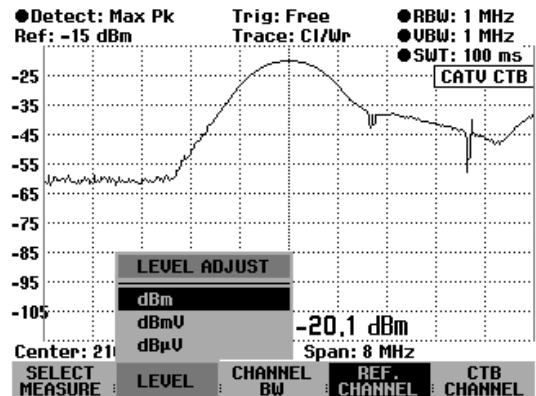

**Measuring the Composite Triple Beat Distortion**

Composite triple beat distortion refers to unwanted intermodulation products of the vision carriers that occur at nonlinearities. They are third-order intermodulation products and occur with vision carrier frequencies at the channel spacings. In cable TV systems, the individual intermodulation products are "piling up".

The R&S FSH3-TV measures these interference products in an unoccupied channel and determines their ratio to the reference power.

In the measurement example, CTB products occur at 203.25 MHz, 231.25 MHz and 637.25 MHz, for example. The composite triple beat distortion is measured in a channel with a vision carrier frequency of 203.25 MHz.

The figure at the right shows the frequency spectrum of the measurement example and explains how CTB products occur.

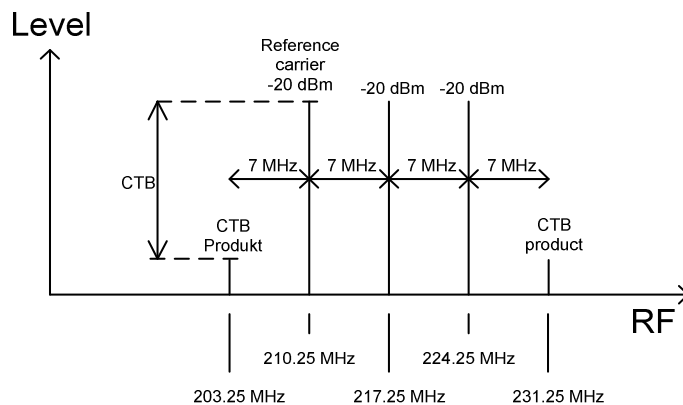



**Switchover to the CTB measurement:**

- Press the MEAS key.
- Press the CTB MEASURE softkey.
- Using the cursor keys or the rotary knob, select VISION CARR FREQ... from the menu and confirm your choice with the ENTER key or the CTB MEASURE softkey.

The R&S FSH3-TV opens the entry field for setting the vision carrier frequency.

- Using the numeric keypad, enter 203.25 and confirm the entry with the MHz key.

The R&S FSH3-TV sets the receive frequency to a vision carrier frequency of 203.250000 MHz.

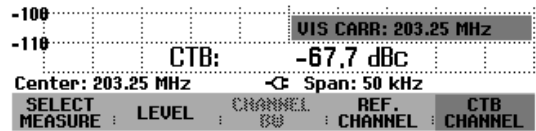
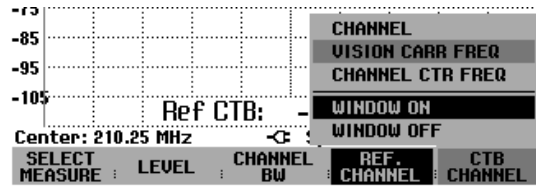

**Setting the reference level:**

The reference level is set manually in the AMPT menu. To simplify operation and to prevent incorrect measurements, the R&S FSH3-TV has an automatic routine for setting the reference level. During the CTB measurement, the LEVEL ADJUST function measures the power of the CTB noise "pile" depending on the reference level and then sets the reference level where the CTB noise power is lowest. This ensures that the R&S FSH3-TV is optimally set, irrespective of the channels and levels of the input signal.

- Press the MEAS key.
- If the CTB measurement is active, press the LEVEL softkey.
- Confirm with the ENTER key or the LEVEL softkey.

The measurement screen displays the frequency spectrum around the vision carrier with a span of 50 kHz. The measurement settings are made in compliance with the EN 50083 test specification.

The measured CTB ratio is displayed in the lower half of the measurement screen. The reference power used for calculations is displayed in the upper left corner of the screen.

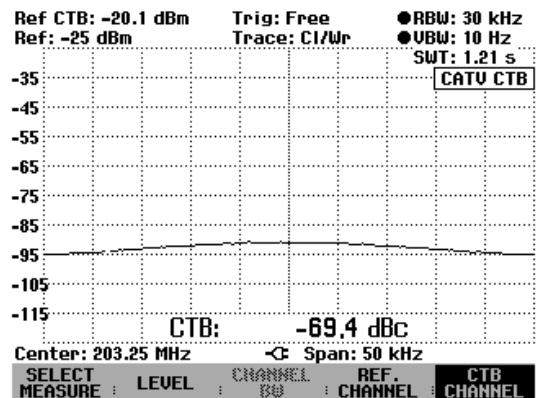

## Measuring the Composite Second Order Ratio

For measuring the ratio of the composite second order (CSO) intermodulation products to the carrier power in accordance with the EN 50083 standard, the R&S FSH3-TV offers the CSO measurement in the CABLE TV menu. It performs the measurement in two steps. First, the reference power is measured, or a reference power is determined which is then used to calculate the CSO ratio. In the second step, the R&S FSH3-TV measures the power of the CSO intermodulation products in an unoccupied transmission channel and calculates their ratio to the reference power.

The following measurement example shows the individual steps used to effectively perform this measurement with the R&S FSH3-TV.

For the measurement example to be reproducible, only an analog TV test transmitter such as the TV Test Transmitter R&S SFM together with the CCVS + Component Generator R&S SAF and a signal generator such as the Signal Generator R&S SML are used as signal sources.

### Measurement setup:

Connect the R&S SAF video output to the R&S SFM video input. Add the RF output signals via a coupler and connect them to the R&S FSH3-TV RF input.

Settings on the video signal generator:

Standard                    PAL, 625 lines

Settings on the analog TV test transmitter:

Standard                    B/G, FM-IRT-A2 dual-channel sound

Group delay                general

Frequency                  521.25 MHz

Level                        -20 dBm

Settings on the signal generator:

Frequency                  569.25 MHz

Level                        -20 dBm

The figure at the right shows the spectrum of the described measurement setup.

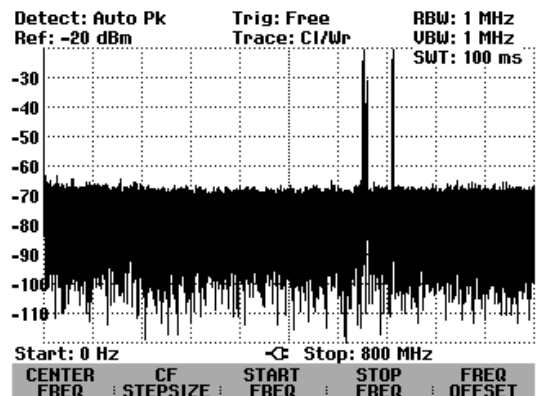

Set the R&S FSH3-TV to its default settings to show all the operating steps that are required.

➤ Press the PRESET key.

The analyzer displays the frequency spectrum from 100 kHz to 3 GHz – the R&S FSH3-TV's entire frequency span. With 521.25 MHz and 569.25 MHz, the generator signals are displayed as lines. Generator harmonics can also be seen as lines at frequencies that are multiples of 521.25 MHz and 569.25 MHz.

**Activating the composite second order measurement:**

- Press the MEAS key.
- Press the MEASURE softkey.
- Using the cursor keys or the rotary knob, select CABLE TV from the menu and confirm your choice with the ENTER key or the MEASURE softkey.

The R&S FSH3-TV opens the CABLE TV menu.

- Using the rotary knob or the cursor keys, select CSO from the menu and confirm your choice with the ENTER key or the MEASURE softkey.

The R&S FSH3-TV activates the CSO measurement mode and starts the reference carrier measurement.

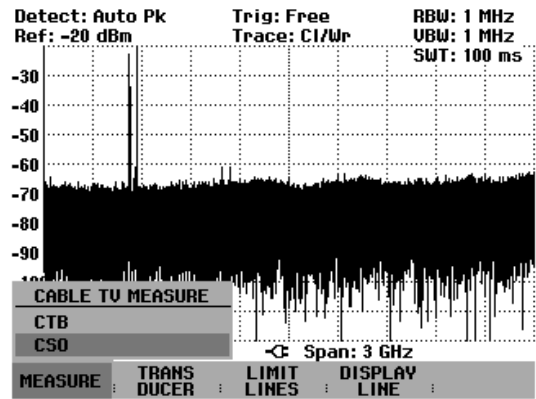

**Measuring the Reference Power**

The reference power is either measured in an analog TV channel or can be defined manually. If the vision carriers are modulated negatively, the reference power is the vision carrier power at the time of the sync pulse.

In the example, the reference channel is the analog TV signal with a vision carrier frequency of 521.25 MHz.

- Press the MEAS key.
- Press the REF MEASURE softkey.
- Using the cursor keys or the rotary knob, select VISION CARR FREQ... from the menu and confirm your choice with the ENTER key or the REF MEASURE softkey.

The R&S FSH3-TV opens the entry field for setting the vision carrier frequency.

- Using the numeric keypad, enter 521.25 and confirm the entry with the MHz key.

The R&S FSH3-TV sets the receive frequency to a vision carrier frequency of 521.250000 MHz.

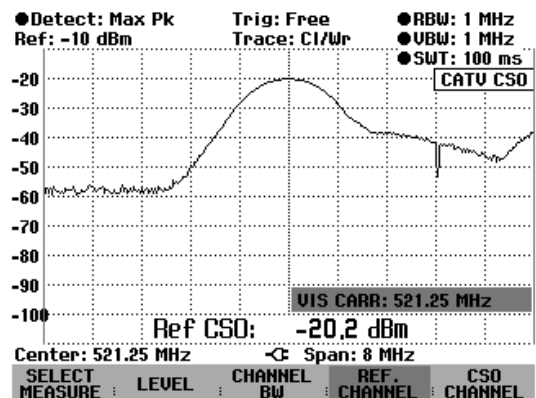
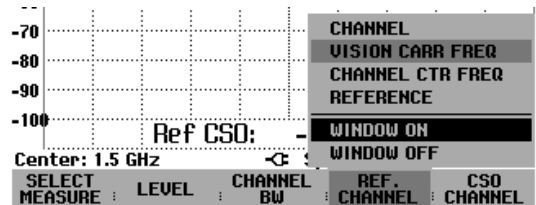

The measurement screen displays the analog TV channel spectrum with a vision carrier frequency of 521.250 MHz. The frequency span corresponds to the channel bandwidth of the analog TV standard set in the SETUP – LOCAL SETTINGS menu.

The channel bandwidth can also be set manually.

- Press the MEAS key.
- Press the CHANNEL BW softkey.

The R&S FSH3-TV opens the entry field for setting the channel bandwidth.

- Using the numeric keypad, enter 8 and confirm the entry with the MHz key.
- The R&S FSH3-TV sets the channel bandwidth to 8 MHz.

**Setting the reference level:**

The reference level is set manually in the AMPT menu. To simplify operation and to prevent incorrect measurements, the R&S FSH3-TV has an automatic routine for setting the reference level. During the reference level measurement, the LEVEL ADJUST function measures the maximum receive level and sets the reference level accordingly.

- Press the MEAS key.
- If the reference measurement is active, press the LEVEL softkey.
- Using the rotary knob or the cursor keys, select LEVEL ADJUST and confirm your choice with the ENTER key or the LEVEL softkey.

The measurement screen displays the reference channel spectrum. The measured reference power is displayed in the lower half of the screen. The reference level is output in dBm, dBμV or dBmV.

- Press the MEAS key.
- Press the LEVEL softkey.
- Using the rotary knob or the cursor keys, select the unit you want and confirm your choice with the ENTER key or the LEVEL softkey.

The reference measurement result is displayed in the selected unit.

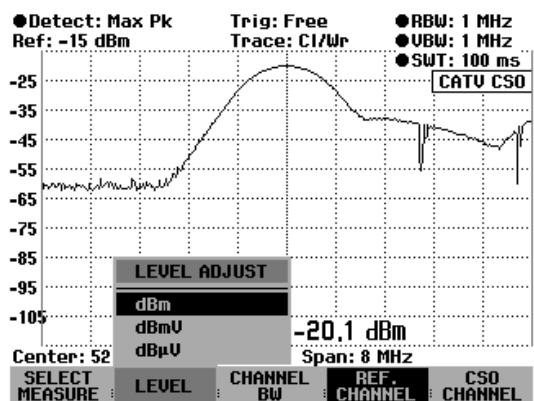

### Measuring the Composite Second Order Distortion

Composite second order distortion refers to unwanted intermodulation products of two vision carriers that occur at nonlinearities. In cable TV systems, the individual second order intermodulation products are "piling up".

The R&S FSH3-TV measures these noise products in an unoccupied channel and determines their ratio to the reference power.

At nonlinearities, the two RF signals of the measurement example generate composite second order noise products at 48.00 MHz (= 569.25 MHz – 521.25 MHz) and at 1090.50 MHz (= 569.25 MHz + 521.25 MHz). The noise product at 48.00 MHz is part of the transmission channel 2 with a vision carrier frequency of 48.25 MHz.

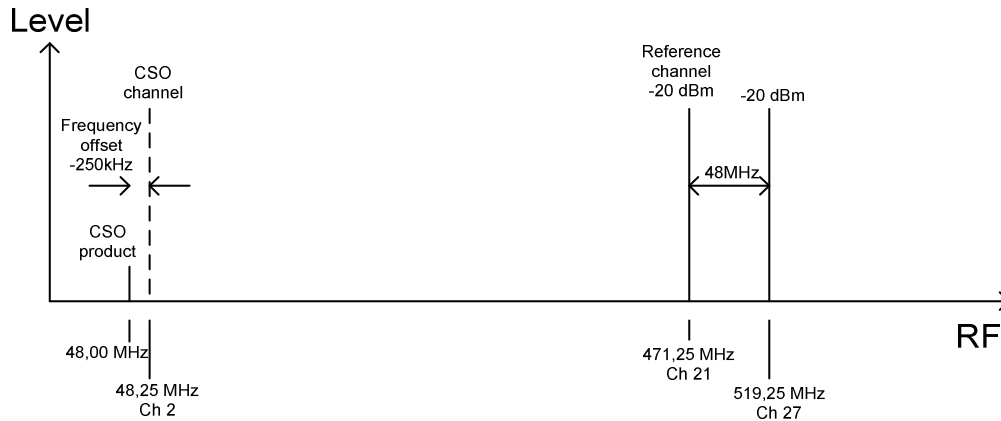

#### Switchover to the CSO measurement:

- Press the MEAS key.
- Press the CSO MEASURE softkey.
- Using the cursor keys or the rotary knob, select VISION CARR FREQ... from the menu and confirm your choice with the ENTER key or the CSO MEASURE softkey.

The R&S FSH3-TV opens the entry field for setting the vision carrier frequency.

- Using the numeric keypad, enter 48.25 and confirm the entry with the MHz key.

The R&S FSH3-TV sets the TV channel 2 with a vision carrier frequency of 48.250000 MHz and measures the CSO product. The R&S FSH3-TV measures the noise power at the vision carrier offset frequencies ± 250 kHz and sets the measurement frequency to the maximum noise value.

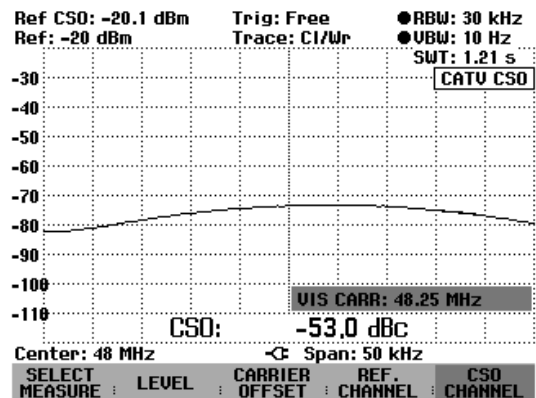

**Setting the carrier frequency offset:**

The frequency offset to the vision carrier can be set manually.

- Press the MEAS key.
- Press the CARRIER OFFSET softkey.
- Using the cursor keys or the rotary knob, select the carrier frequency offset you need from the menu and confirm your choice with the ENTER key or the CARRIER OFFSET softkey.

The R&S FSH3-TV measures the distortion at the frequency vision carrier frequency plus offset frequency and calculates the CSO ratio.

**Setting the reference level:**

The reference level is set manually in the AMPT menu. To simplify operation and to prevent incorrect measurements, the R&S FSH3-TV has an automatic routine for setting the reference level. During the CSO measurement, the LEVEL ADJUST function measures the power of the CSO-specific vision carrier offset frequencies. Depending on the reference level, the CSO noise power of the offset frequency is measured which has yielded the highest power. The R&S FSH3-TV sets the reference level where the CSO noise power is lowest. This ensures that the R&S FSH3-TV is optimally set, irrespective of the channels and levels of the input signal.

- Press the MEAS key.
- If the CSO measurement is active, press the LEVEL softkey.
- Using the rotary knob or the cursor keys, select LEVEL ADJUST and confirm your choice with the ENTER key or the LEVEL softkey.

The measurement screen displays the frequency spectrum around the vision carrier with a span of 50 kHz. The measurement settings are made in compliance with the EN 50083 test specification.

The measured CSO ratio is displayed in the lower half of the measurement screen. The reference power used for the calculation is displayed in the upper left corner of the screen.

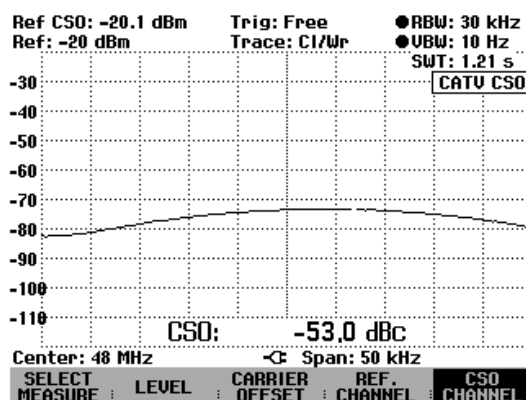

## Measuring the Frequency Response of the Cable TV System

One of the most important parameters of cable TV systems is the system's frequency response. To measure this parameter, the R&S FSH3-TV provides the scan mode in the receiver mode. For example, the frequency response can be measured by measuring the vision carrier power of the analog TV channels.

For the receiver mode, you need the option R&S FSH-K3 (Order No. 1157.3429.02).

Using the R&S FSH View PC software, generate a channel table that contains only the analog TV channels to be used for determining the frequency response. Then load this channel table to the R&S FSH3-TV.

- Start R&S FSH View on the PC.
- Open the Channel Table Editor tool.

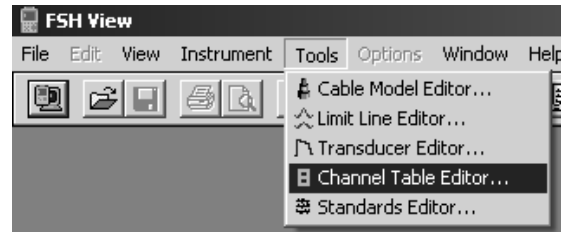

- Enter the channels for determining the frequency response of the cable network into the channel table.

In the measurement example, the frequency response is to be determined by measuring the vision carriers with the frequencies

- 48.25 MHz
- 210.25 MHz
- 471.25 MHz
- 703.25 MHz

- Save the channel table.
- Close the Channel Table Editor.
- Open the Channel Table Control tool.
- Transfer the channel table to the R&S FSH3-TV.

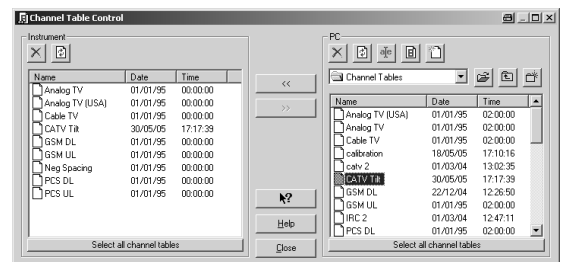
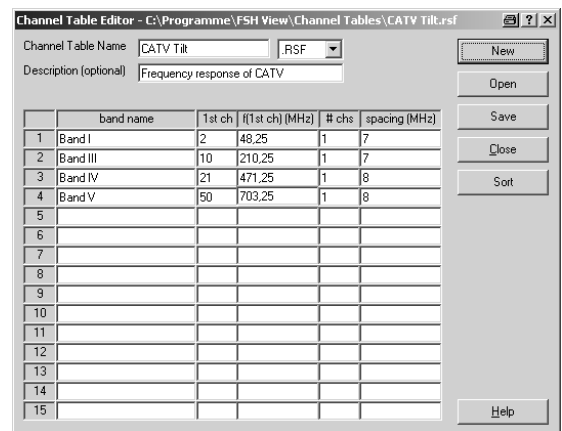

Select the Receiver mode.

- Press the MEAS key.
- Press the MEASURE softkey.
- Using the rotary knob or the cursor keys, select RECEIVER from the menu and confirm with the ENTER key or the MEASURE softkey.

Select the Channel mode.

- Press the **FREQ** key.
- Press the **CHANNEL MODE** softkey.

The R&S FSH3-TV opens the channel table list.

- Using the rotary knob, select the channel table (CATV Tilt in the measurement example) and confirm with the **SELECT** softkey.

01/01/1995	BAND TABLE LIST	01:32:49
<b>CATV Tilt</b>	30/05/2005 17:17:39	
PCS DL	01/01/1995 00:00:00	
PCS UL	01/01/1995 00:00:00	
GSM DL	01/01/1995 00:00:00	
GSM UL	01/01/1995 00:00:00	
Neg Spacing	01/01/1995 00:00:00	
Analog TV (USA)	01/01/1995 00:00:00	
Cable TV	01/01/1995 00:00:00	
Analog TV	01/01/1995 00:00:00	

<b>SELECT</b>	<b>SELECT</b>	<b>EXIT</b>	<b>DEFINE</b>	<b>LIST-&gt;</b>
: USER TAB :	: USER TAB :		: USER TAB :	: PRINTER :

Activate the Scan mode.

- Press the **SPAN** key.
- Press the **FREQ SCAN** softkey.

The frequency axis is scaled in accordance with the channel table.

The four channels are displayed as level columns. Alternatively the frequency response can be displayed as a frequency polygon. The conversion is effected in the **TRACE / TRACE STYLE** menu.

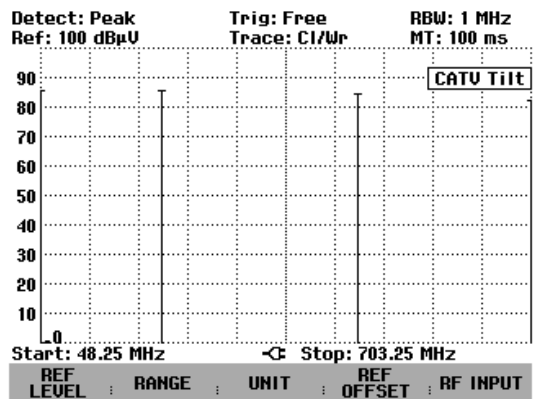

The most important settings such as reference level, measurement bandwidth, detector and measurement time are centralized in the **MEASURE** menu,

Set the reference level, ensuring that no level exceeds the reference level.

A measurement bandwidth of 300 kHz is advisable for measuring the vision carrier level. This ensures that the maximum level is still registered and existing adjacent channels are suppressed.

Select the peak detector to measure the vision carrier level correctly.

A measurement time of 100 ms is recommended.



For a better evaluation of the frequency response, change the level range.

- Press the AMPT key.
- Press the RANGE softkey.
- Using the rotary knob or the cursor keys, select the desired level range and confirm your choice with the ENTER key or the RANGE softkey.

In the measurement example a level range of 1 dB/div has been selected.

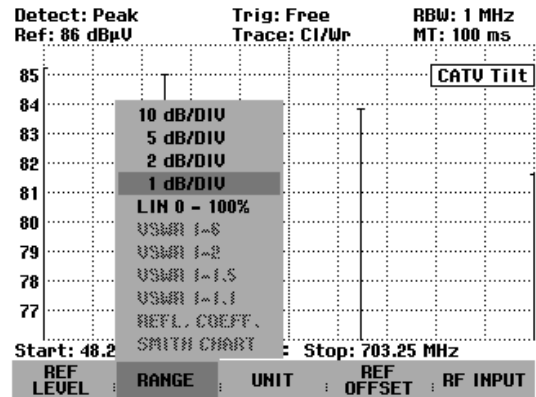

Using the marker function, the frequency response results can also be displayed numerically.

- Press the MARKER key.
- Press the MARKER MODE softkey.
- Using the rotary knob or the cursor keys, select MULTI MARKER and confirm your choice with the ENTER key or the MARKER MODE softkey.

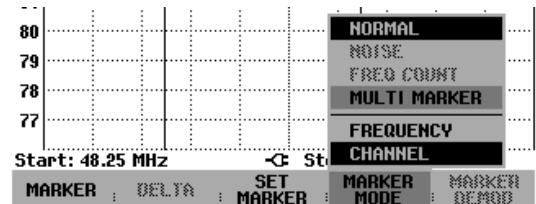

Activate markers 1 to 4 and assign them to the four measurement channels.

Activate marker 1 and assign it to channel 2.

- Press the MARKER softkey and confirm with the ENTER key or the MARKER softkey.
- Using the rotary knob, assign MARKER 1 to channel 2.

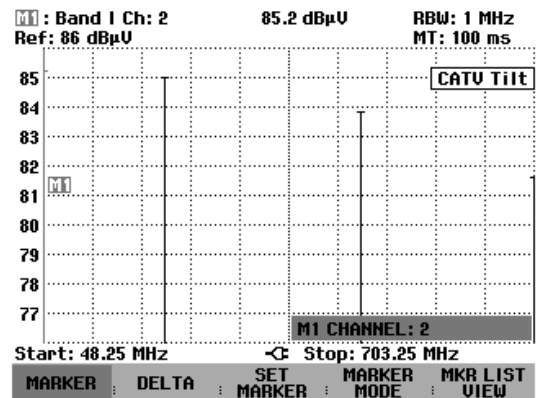

Activate marker 2 and assign it to channel 10.

- Press the MARKER key.
- Using the rotary knob or the cursor keys, select MARKER 2 and confirm your choice with the ENTER key or the MARKER softkey.

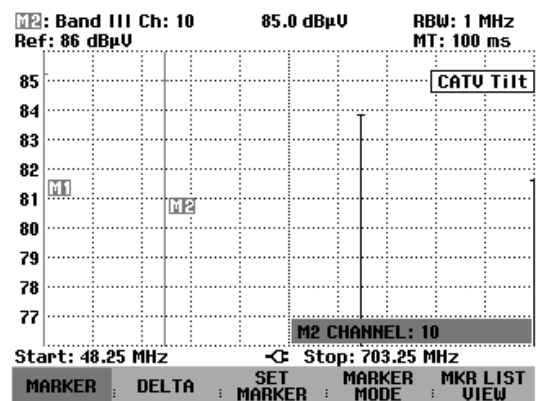

Activate markers 3 and 4 accordingly and assign them to channels 21 and 50.

Activate markers 3 and 4 analogously to the marker 2 example and assign them to channels 21 and 50.

Insert the marker list.

- Press the MKR LIST VIEW softkey.

The R&S FSH3-TV inserts the measured level values of the measurement channels.

➤

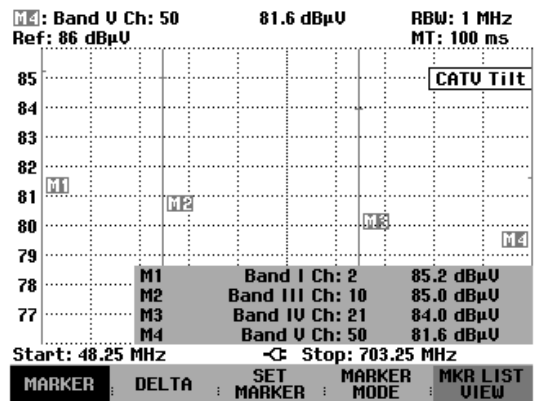

Instead of the channel information, the frequency of the measurement channels can be alternatively displayed in the list.

- Press the MARKER MODE softkey.
- Using the rotary knob or the cursor keys, select FREQUENCY and confirm your choice with the ENTER key or the MARKER MODE softkey.
- Press the MKR LIST VIEW softkey.

The R&S FSH3-TV inserts the frequency of the measurement channels plus the associated measured level values.

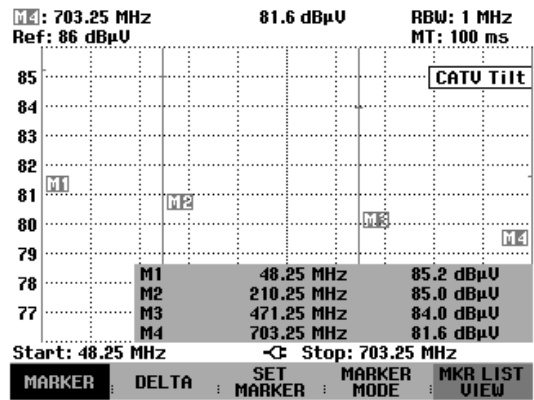

Note: For further detailed operating instructions, refer to the 'Operation in Receiver Mode' section.

## Power Measurements Using the Power Sensor

For highly accurate power measurements, the R&S FSH3-TV provides the Power Sensors R&S FSH-Z1 or R&S FSH-Z18 as options. They measure power in the span 10 MHz to 8 GHz or 10 MHz to 18 GHz, respectively.

The power sensors are controlled and powered via a special RS-232-C interface at the top of the instrument.

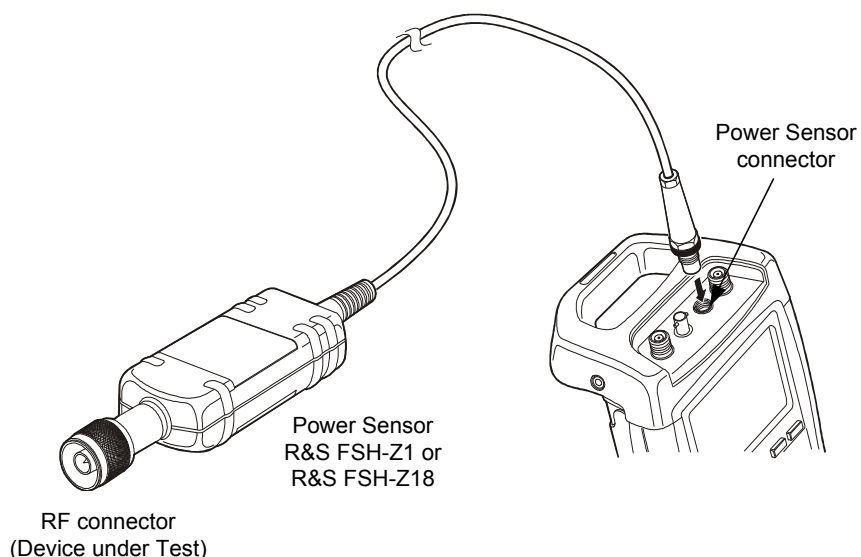

*The continuous power applied to the power sensor's input must not exceed 400 mW (26 dBm). However, brief ( $\leq 10 \mu\text{s}$ ) power peaks up to 1 W (30 dBm) are permissible. Higher input powers can destroy the sensor. An attenuator pad must be used to ensure that the maximum permissible power for the sensor is never exceeded when measurements are made on high-power transmitters.*

- Connect the power sensor cable to the R&S FSH3-TV's power sensor connector and screw it into position.
- Press the MEAS key.
- Press the MEASURE softkey.
- Using the cursor keys or the rotary knob, select the POWER SENSOR menu item and confirm your selection with the ENTER key or the MEASURE softkey.

The R&S FSH3-TV opens the screen for power measurements. If a power sensor has not been connected, no measured value is displayed. If a power sensor has been connected, the R&S FSH3-TV sets up a connection via the RS-232-C interface and, after a few seconds, displays the measured power.

If there are any communications problems with the power sensor, the R&S FSH3-TV outputs error messages (sensor error: error number) indicating the possible causes (see operating manual).

To compensate for internal offset of the power meter, the power sensor needs to be compensated before starting the measurement.

- Press the ZERO softkey.

The R&S FSH3-TV outputs a message telling you not to apply any signals to the power meter while zeroing is being performed.

- Disconnect the power sensor from any signal sources.
- Start zeroing with the first or second softkey (CONTINUE).

The R&S FSH3-TV immediately starts power meter zeroing. While this process is being performed, the R&S FSH3-TV outputs the message "Zeroing power sensor, please wait..".

When zeroing is over, the R&S FSH3-TV outputs the message "Power Sensor Zero OK" and switches back to the softkey menu for the power sensor.

- Connect the signal under test to the RF connector of the R&S FSH-Z1.

The R&S FSH3-TV shows the measured power level in dBm.

For highly accurate measurements, enter the frequency of the signal under test.

- Press the FREQ softkey.
- Using the numeric keys, enter the frequency you want and confirm the entry with the ENTER key or by pressing the FREQ softkey again.

The R&S FSH3-TV transfers the new frequency to the power sensor which then corrects the measured power readings.

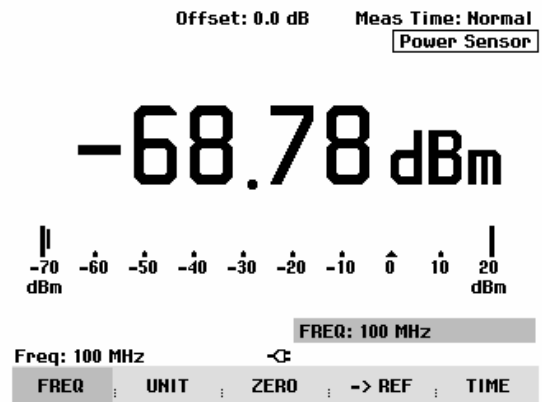
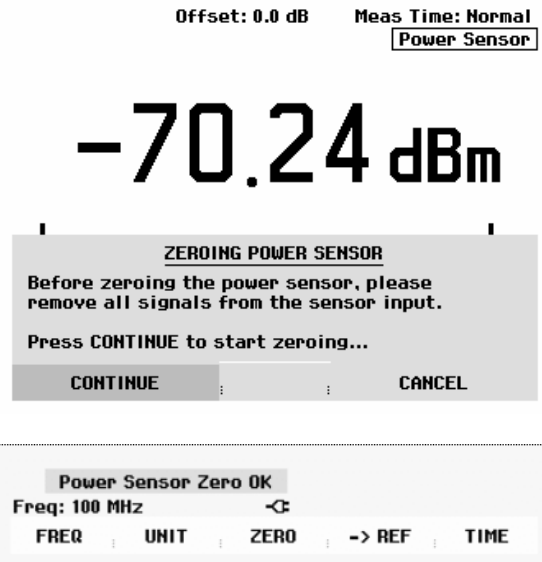

## Measurements Using the Tracking Generator

### Power and Return Loss Measurements with the R&S FSH-Z14 or the R&S FSH-Z44

The Directional Power Sensors R&S FSH-Z14 and R&S FSH-Z44 are connected between the source and the load and measure the power flux in both directions, i.e. from the source to the load (forward power) and from the load to the source (reverse power). The ratio between reverse power and forward power is a measure of the load matching and is displayed as the return loss or standing wave ratio.

The R&S FSH-Z14 and the R&S FSH-Z44 have an asymmetrical design and must therefore be inserted into the test setup in such a way that the FORWARD arrow on the sensor points toward the load (= in the direction of the power flux).

They are driven and powered via a special serial interface.

The cable on the power sensor must be connected and screw-fastened to the power sensor connector on the R&S FSH3-TV. The directional power sensor itself has to be inserted between the source and the load.

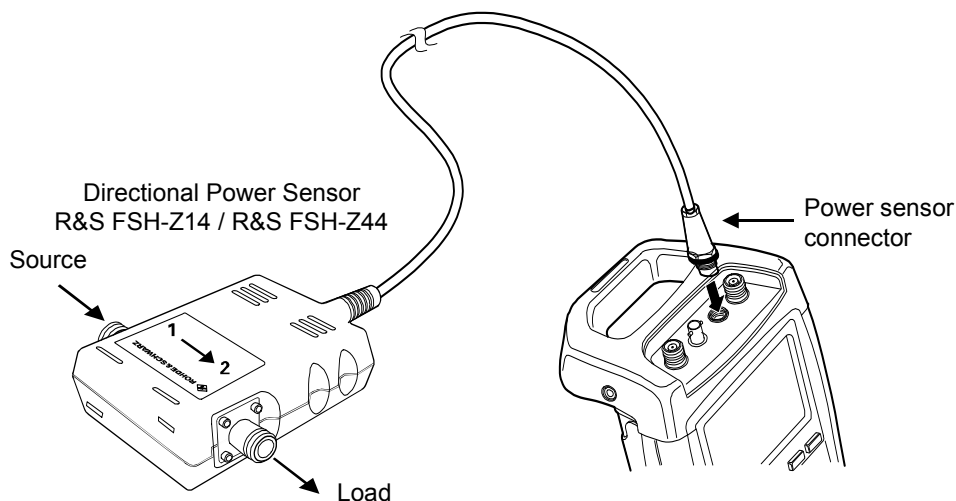

When measuring high powers, pay strict attention to the following instructions to avoid personal injury and to prevent the power sensor from being destroyed:



- Never exceed the permissible continuous power (see diagram on the rear of the sensor).
- Connect the sensor only when the RF power is off.
- The RF connectors must be screwed tight.

Failure to follow these rules can lead to injuries such as skin burns or cause the destruction of the measurement instruments in use.

#### Operation:

- Press the MEAS key.
- Press the MEASURE softkey.

The R&S FSH3-TV opens the menu for the measurement functions.

Using the cursor keys or the rotary knob, select POWER SENSOR and confirm with the ENTER key or by pressing the MEASURE softkey.

The R&S FSH3-TV opens the screen and the menu for the power measurement. If no power sensor is connected, no measured value is displayed. If a power sensor is connected, the R&S FSH3-TV establishes a connection to the power sensor via the interface and, after a few seconds, displays the connected power sensor type (R&S FSH-Z14 or R&S FSH-Z44) as well as the measured forward power and return loss of the load.

Before performing the power measurement, zero the power sensor.

- Press the ZERO softkey.

The R&S FSH3-TV informs you not to apply any signals while the power sensor is being zeroed.

- Disconnect the power sensor from any signal sources.
- Start zeroing with the first or second softkey (CONTINUE).

Softkey 4 or 5 (CANCEL) can be used to cancel zeroing before it begins, e.g. if the signal source cannot be disconnected.

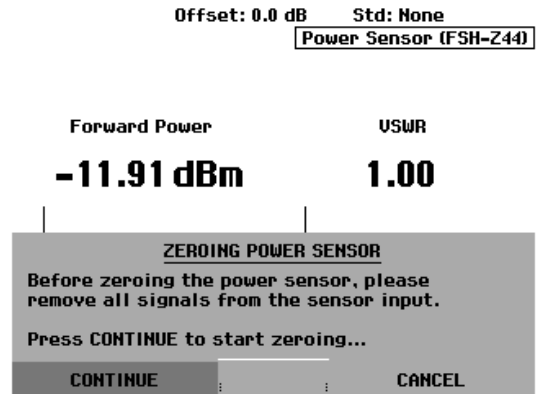

The R&S FSH3-TV immediately starts power sensor zeroing. While this is being done, the R&S FSH3-TV outputs the message "Zeroing power sensor, please wait...".

When zeroing is over, the R&S FSH3-TV outputs the message "Power Sensor Zero OK" and switches back to the softkey menu for the power sensor.

- Now connect the R&S FSH-Z14 or R&S FSH-Z44 between the source and the load.
- The R&S FSH3-TV displays the measured forward power level in dBm and the VSWR of the load.

To achieve maximum measurement accuracy, enter the frequency of the signal under test.

- Press the FREQ softkey.

The R&S FSH3-TV opens the entry box for the frequency.

- Using the numeric keys, enter the desired frequency and terminate the input with the ENTER key or by pressing the FREQ softkey again.

The R&S FSH3-TV transfers the new frequency to the power sensor which then corrects the measured power readings.

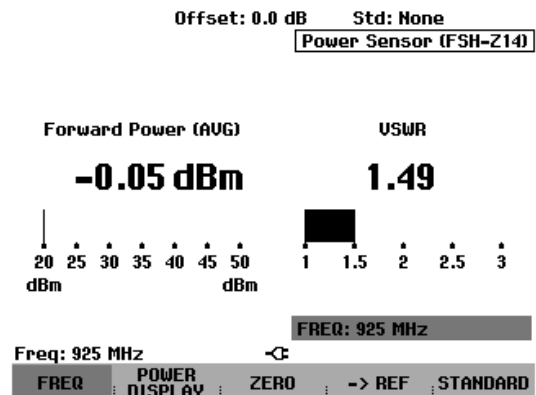

## Two-Port Transmission Measurements

For measurements of the gain or attenuation of two-port devices, the R&S FSH3-TV provides a tracking generator which generates a signal exactly at the current frequency of the R&S FSH3-TV.

- Press the MEAS key.
- Press the MEASURE softkey.

The measurement function menu opens.

- Using the cursor keys or the rotary knob, select the TRACKING GEN menu item and confirm your selection with the ENTER key or the MEAS softkey.

The R&S FSH3-TV switches on the tracking generator and calls up its softkey menu.

When the tracking generator is switched on, the R&S FSH3-TV displays Track Gen Uncal. This indicates that tracking generator measurements are uncalibrated.

Before calibration, the span you want should be set because calibration is valid only for the calibrated span and the reference. Changing the parameters after calibration invalidates calibration.

- Press the FREQ key.
- Using the numeric keys, enter the center frequency.
- Press the SPAN key.
- Using the numeric keys, enter the span.

Alternately, the start and stop frequencies can be entered using the START and STOP softkeys in the frequency menu.

Calibrate the R&S FSH3-TV for the transfer function measurement.

The following example shows a scalar measurement of the transmission function. If the option R&S FSH-K2 is installed, the measurement must first be switched to scalar.

- Press the MEAS key.
- Press the MEAS MODE softkey.
- Using the rotary knob or cursor keys, select SCALAR.
- Confirm with the ENTER key or the MEAS MODE softkey.
- In the main menu for the tracking generator, press the MEAS key.

- Press the TRANSM CAL softkey.

The R&S FSH3-TV now prompts you to connect the RF input to the tracking generator's output so that calibration can be carried out.

- Connect the RF output to the generator's input without the DUT.
- Press the CONTINUE softkey to start calibration.

During calibration, the R&S FSH3-TV outputs the message "Calibrating THROUGH, please wait...".

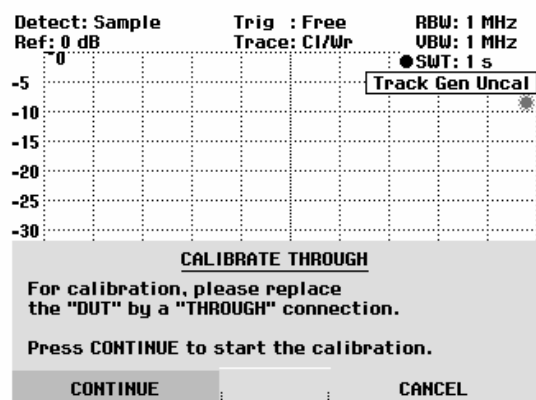

When calibration has been completed, the R&S FSH3-TV outputs the message "Transm. calibrated" for 3 seconds.

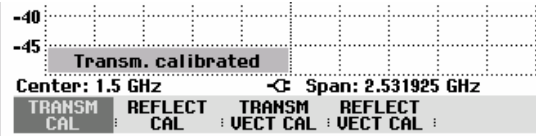

The R&S FSH3-TV now displays **Transmission** in the upper right-hand corner of the measurement diagram. This tells you that the R&S FSH3-TV has been calibrated for transfer function measurements. In addition, the TRANSM CAL softkey label is highlighted in green.

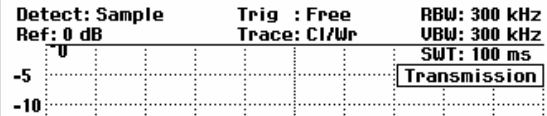

- Connect the DUT between the RF input and the generator's output.

The R&S FSH3-TV displays the magnitude of the transfer function. You can read out values with the markers, for example.

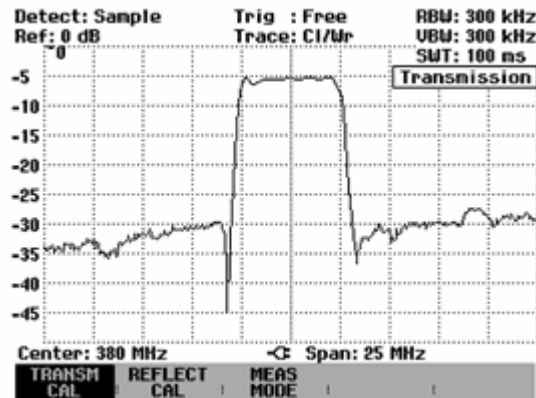

The transmission calibration remains valid until the center frequency or the span is changed on the R&S FSH3-TV. **Track Gen Uncal** is displayed in the upper right-hand corner of the screen if the calibration is no longer valid.

If the reference is changed after calibration, greater measurement uncertainty must be anticipated. The R&S FSH3-TV retains the calibration data but displays a red dot in front of **•Transmission** to indicate possible increase in measurement error.

When saving a data set for a scalar transmission measurement in a calibrated state, the R&S FSH3-TV can store the calibration data along with the other settings (see section "Saving Calibration Data"). Thus, after the setting is recalled, a measurement can be performed without prior calibration, provided that the instrument's temperature does not deviate more than 5 °C from its temperature when the data set was stored.

If the temperature deviation is greater, the R&S FSH3-TV outputs a (red) dot in front of **•Transmission**. A precise measurement can then be made only after a calibration.



## Measurement of Return Loss

For reflection measurements, the VSWR Bridge and Power Divider R&S FSH-Z2 and a short are needed. The R&S FSH-Z2 is screw-connected to the RF input connector and the generator's output.

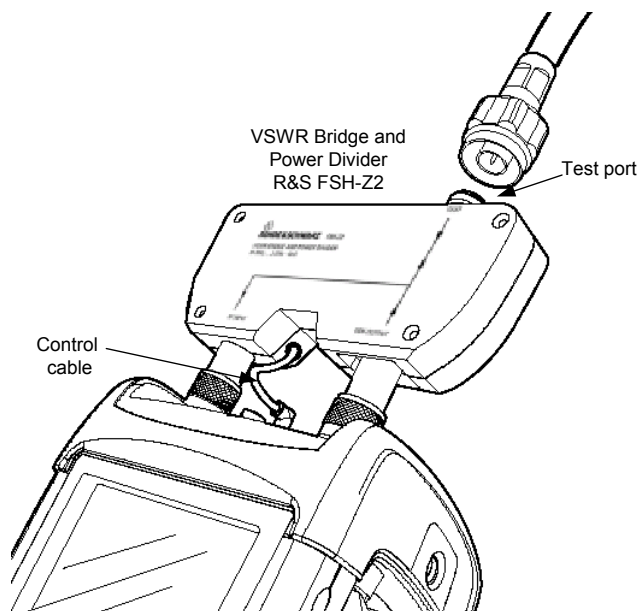

- Connect the control cable of the R&S FSH-Z2 to the power sensor connector of the R&S FSH3-TV.
- Connect the RF and generator port of the R&S FSH-Z2 to the RF input and generator output of the R&S FSH3-TV.

The test setup must be calibrated before any measurements are made. This is done with a short and an open at the point where the reflection measurement is to be made. If a cable is to be inserted between the DUT and the bridge, perform the calibration at the measurement end of the cable.

- Press the MEAS key.
- Press the MEASURE softkey.
- Using the cursor keys or the rotary knob, select TRACKING GEN from the menu and confirm with the ENTER key or the MEAS softkey.

The R&S FSH3-TV switches on the tracking generator and calls up its softkey menu. Since no calibration has been performed, Track Gen Uncal appears in the upper right-hand corner of the measurement diagram.

Before performing calibration, set the required span because calibration is valid only for the calibrated span. Changing the parameters after calibration invalidates calibration.

- Press the FREQ key.
- Using the numeric keys, enter the center frequency.
- Press the SPAN key.
- Using the numeric keys, enter the span.

Alternately, the start and stop frequency can be input using the START and STOP softkeys in the frequency menu.

Calibrate the R&S FSH3-TV for the return loss measurement.

The following example shows a scalar measurement of return loss. If the option R&S FSH-K2 is installed, measurement must first be switched to scalar.

- Press the MEAS key.
- Press the MEAS MODE softkey.
- Using the rotary knob or cursor keys, select SCALAR.
- Confirm with the ENTER key or the MEAS MODE softkey.

- In the main menu for the tracking generator, press the REFLECT CAL softkey.

The R&S FSH3-TV prompts you to leave the measurement port open.

- Leave the measurement port of the bridge or the cable end open.
- Using the CONTINUE softkey, start the OPEN calibration.

While calibration is in progress, the R&S FSH3-TV outputs the message "Calibrating OPEN, please wait...".

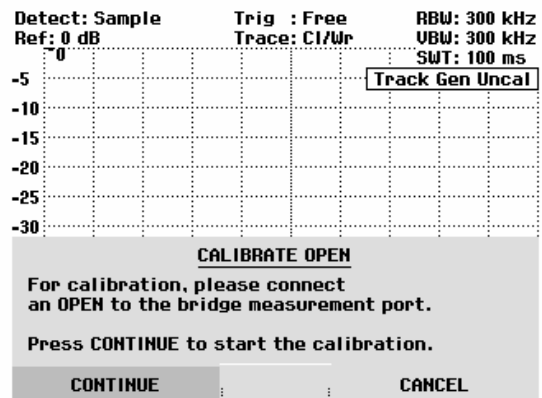

When OPEN calibration is over, the R&S FSH3-TV prompts you to perform SHORT calibration.

- Connect a short to the bridge measurement port.
- Using CONTINUE, start the SHORT calibration.

While calibration is in progress, the R&S FSH3-TV outputs the message "Calibrating SHORT, please wait...".

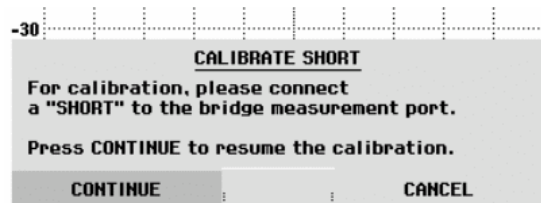

When calibration is over, the R&S FSH3-TV outputs the message "Reflect. calibrated" for 3 seconds.

**Reflection** is displayed in the upper right-hand corner of the measurement diagram to indicate that the R&S FSH3-TV is calibrated for reflection measurements.

- Connect the DUT to the R&S FSH-Z2 measurement port.

The R&S FSH3-TV displays the return loss of the DUT.

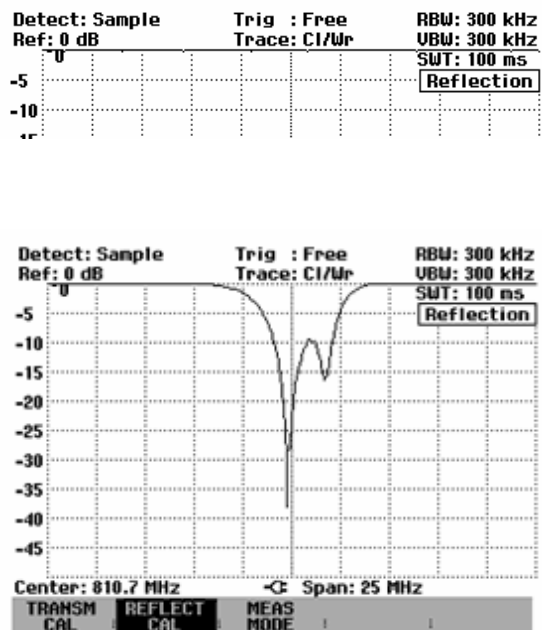

The transmission calibration remains valid until the R&S FSH3-TV's center frequency or span is changed. If calibration becomes invalid, the R&S FSH3-TV displays Track Gen Uncal in the upper right-hand corner of the screen.

If the reference is changed after calibration, a larger measurement uncertainty must be anticipated. The R&S FSH3-TV retains the calibration data but places a red dot in front of the • Reflection display to indicate possible increase in measurement uncertainty.

When saving a data set for a scalar reflection measurement in a calibrated state, the R&S FSH3-TV can store the calibration data along with the other settings (see section "Saving Calibration Data"). Thus, after the setting is recalled, a measurement can be performed without prior calibration, provided that the instrument's temperature does not deviate more than 5 °C from its temperature when the data set was stored.

If the temperature deviation is greater, the R&S FSH3-TV outputs a (red) dot in front of • Reflection. A precise measurement can then be made only after a calibration.

## Performing Distance-To-Fault Measurements

(Only for the R&S FSH3-TV with the installed option R&S FSH-B1 (distance-to-fault measurement) and the VSWR Bridge and Power Divider R&S FSH-Z2)

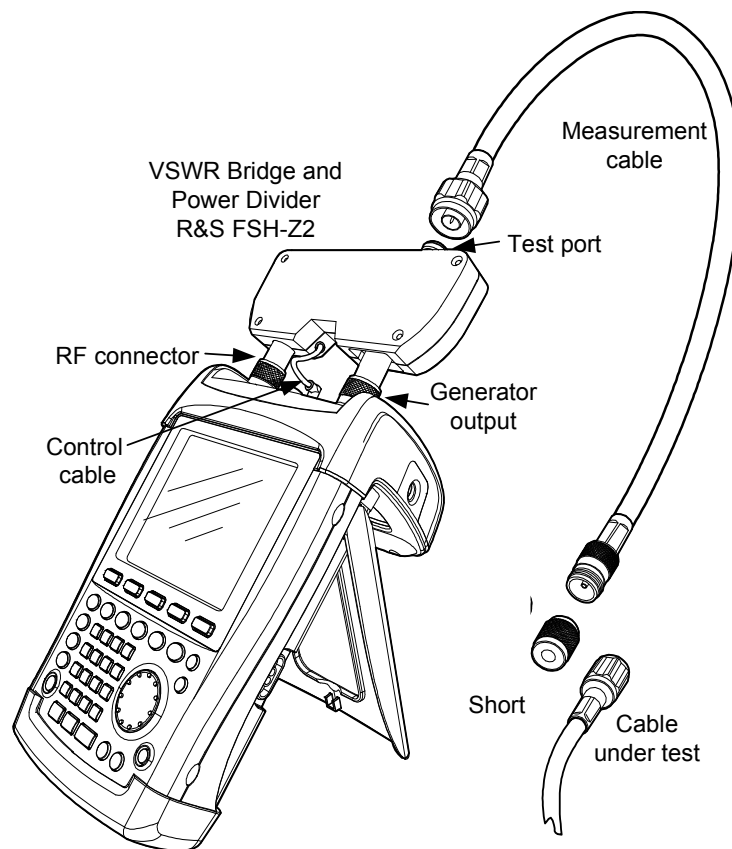

- Connect the control cable of the R&S FSH-Z2 to the power sensor connector of the R&S FSH3-TV.
- Connect the RF and generator port of the R&S FSH-Z2 to the RF input and generator output of the R&S FSH3-TV.
- Connect the 1 m test cable supplied with option R&S FSH-B1 to the bridge test port.

*Note:* The 1 m cable must be used. Results are invalid without this cable.

- Press the MEAS key.
- Press the MEASURE softkey.
- Using the cursor keys or rotary knob, select DISTANCE TO FAULT from the menu and confirm with the ENTER key or the MEAS softkey.

The R&S FSH3-TV switches on the distance-to-fault measurement function. The R&S FSH3-TV delivers optimum results if the center frequency is set to the frequency at which the device under test is operated.

- Press the FREQ key.
- Input the center frequency, e.g. frequency of the antenna at the end of the cable under test.

To perform distance-to-fault cable measurements, the R&S FSH3-TV needs to be informed about the type of cable and its approximate length. Frequency-dependent cable models can be generated with the supplied R&S FSH View software for Windows and loaded onto the R&S FSH3-TV. The procedure is described in the R&S FSH View manual. The cable parameters for a frequency can also be entered directly.

**Selecting a cable model from the list:**

- Press the MEAS key.
- Press the CABLE MODEL softkey.

The R&S FSH3-TV displays the list of loaded cable models.

- Using the rotary knob or the cursor keys, select the appropriate cable model.
- Using the SELECT softkey, activate the cable model you have selected.

The analyzer returns to the DTF measurement menu and displays the cable used for the measurement in the upper right-hand corner of the screen.

10/06/2003	CABLE LIST	10:53:28
RTK161SG	18/12/2002 18:27:24	
RG8U	18/12/2002 18:27:24	
RG58C	18/12/2002 18:27:24	
<b>RG223U</b>	<b>18/12/2002 18:27:24</b>	
RG214	18/12/2002 18:27:24	
RG213U	18/12/2002 18:27:24	
RG142	18/12/2002 18:27:24	
RG141A	18/12/2002 18:27:24	
LMR900	18/12/2002 18:27:24	
LMR600	18/12/2002 18:27:24	
LMR1200	18/12/2002 18:27:24	

SELECT	SELECT USER MOD	EXIT	DEFINE USER MOD	LIST-> PRINTER
--------	-----------------	------	-----------------	----------------

**Entering the cable parameters at a specific frequency:**

If cables are used that are not listed in cable models stored in the R&S FSH3-TV, it is possible to enter the cable parameters at a specific frequency. It is advisable to use the center frequency of the DTF measurement.

- Press the MEAS key.
- Press the CABLE MODEL softkey.

The R&S FSH3-TV displays the list of loaded cable models (if available).

- Press the SELECT USER MOD softkey.

The softkey is highlighted in green to indicate that a user-specific cable model has been chosen.

The cable model is defined with the DEFINE USER MOD softkey.

10/06/2003	CABLE LIST	11:02:34
<b>RTK161SG</b>	<b>18/12/2002 18:27:24</b>	
RG8U	18/12/2002 18:27:24	
RG58C	18/12/2002 18:27:24	
RG223U	18/12/2002 18:27:24	
RG214	18/12/2002 18:27:24	
RG213U	18/12/2002 18:27:24	
RG142	18/12/2002 18:27:24	
RG141A	18/12/2002 18:27:24	
LMR900	18/12/2002 18:27:24	
LMR600	18/12/2002 18:27:24	
LMR1200	18/12/2002 18:27:24	

SELECT	<b>SELECT USER MOD</b>	EXIT	DEFINE USER MOD	LIST-> PRINTER
--------	------------------------	------	-----------------	----------------

- Press the DEFINE USER MOD softkey.

The R&S FSH3-TV opens a submenu for defining the FREQUENCY, the VELOCITY FACTOR and the ATTENUATION.

FREQUENCY...  
VELOCITY FACTOR...  
ATTENUATION...

SELECT	<b>SELECT USER MOD</b>	EXIT	DEFINE USER MOD	LIST-> PRINTER
--------	------------------------	------	-----------------	----------------

- Using the rotary knob or the cursor keys, select the appropriate parameter from the submenu and press the ENTER key.

- Enter the value (e. g. velocity factor) for the cable used.

VELOCITY FACT: 1.000

- Confirm with the ENTER key.

SELECT	<b>SELECT USER MOD</b>	EXIT	DEFINE USER MOD	LIST-> PRINTER
--------	------------------------	------	-----------------	----------------

Please refer to the cable manufacturer's data sheet for the velocity factor (= speed of wave in the cable relative to the speed of light) and the attenuation of the cable per meter or per foot at the specified frequency.

- Use the EXIT softkey to exit the menu for defining the cable model.

The analyzer returns to the DTF measurement menu and displays the cable used for the measurement in the upper right-hand corner of the screen.

The R&S FSH3-TV uses the cable length to determine the optimal span for the measurement and for scaling the x axis in DTF mode. For best results, the cable should be specified 20% to 50% longer than the actual cable length.

- Press the CABLE LENGTH softkey.

The R&S FSH3-TV opens the cable length (CABLE LEN) value entry box and displays the current length setting.

- Using the numeric keys, enter the cable length in meters and terminate the entry with the ENTER key or one of the unit keys, or
- Using the rotary knob (1 m steps) or the cursor keys (10 m steps), adjust the cable length.

If the unit of length is set to Feet (via SETUP: LOCAL SETTINGS), the entry is in feet.

The minimum cable length is 3 m. The maximum cable length that can be set is 1000 m.

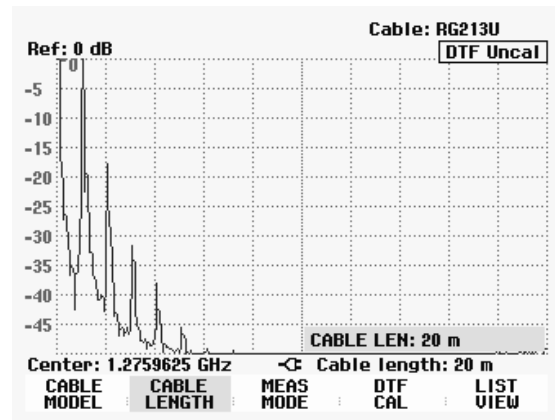

**Calibrating the test setup:**

The test setup must be calibrated before any measurements are performed.

- Press the DTF CAL softkey.

The R&S FSH3-TV opens a text window that prompts you to terminate the measurement cable with a SHORT.

- Firmly screw the SHORT to the output end of the measurement cable.
- Press the CONTINUE softkey to start the SHORT calibration.

While the SHORT calibration is in progress, the R&S FSH3-TV outputs the message "Calibrating SHORT, please wait...".

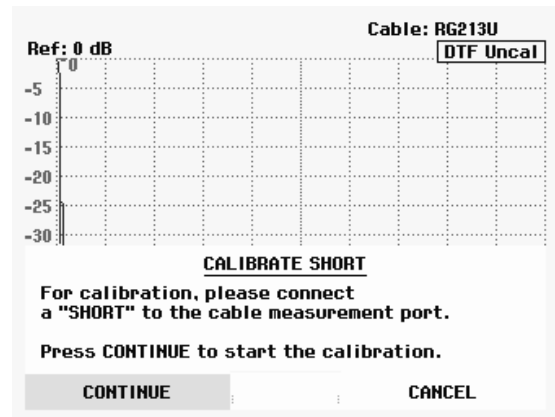

When calibration is over, the R&S FSH3-TV displays **DTF CAL** in the upper right-hand corner of the screen.

**Calibration tip:**

The R&S FSH3-TV performs calibration over its entire span. Therefore, recalibration is not necessary after the cable length is changed. The calibration data is stored in the R&S FSH3-TV memory. Thus, the calibration is valid after the operating mode is changed or after the instrument is switched off. For a calibration to remain valid, the instrument temperature must not deviate more than 5°C. If the temperature deviates more than this amount, the R&S FSH3-TV shows a red dot in front of the **DTF display**. A new calibration is then necessary.

- Unscrew the short from the measurement cable.
- Screw the cable under test to the measurement cable.

The R&S FSH3-TV displays the return loss produced in the cable under test versus the distance.

The R&S FSH3-TV can also list any cable faults. It displays the return loss and distance from the measurement plane of all reflections that exceed a definable threshold.

- Press the LIST VIEW softkey.

The R&S FSH3-TV opens the threshold value entry box and also displays the threshold as a horizontal line across the measurement diagram.

- Set the threshold using the cursor keys (5 dB steps), the rotary knob (1 dB steps) or the numeric keys.

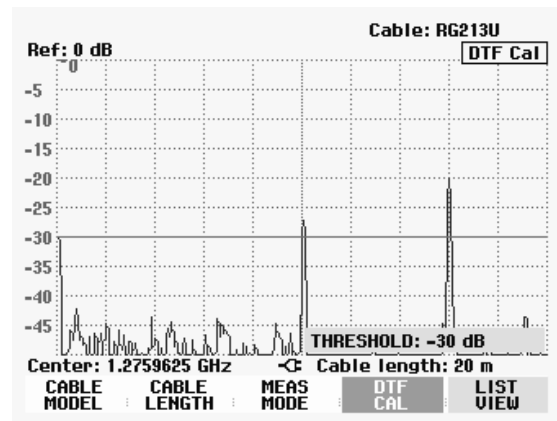

- Press the ENTER key or the LIST VIEW softkey again.

The R&S FSH3-TV displays a table listing all the return losses that are above the threshold, sorted according to distance from the measurement plane.

PEAK	DISTANCE	VALUE
1	10.07 m	-27.3 dB
2	16.00 m	-20.0 dB

- To close the list and to return to the graphical display mode, press the EXIT softkey.

Center: 1.2759625 GHz	Cable length: 20 m
THRES	LIST->
HOLD	PRINTER
	EXIT

- Press the MARKER key.

The R&S FSH3-TV opens the marker menu and places the distance marker on the largest return loss. The marker readout provides the distance of the reflection from the measurement plane in meters and its return loss.

- Change the distance marker by entering a number, adjusting the rotary knob (pixel by pixel) or by using the cursor keys (step = 10 % of the span).

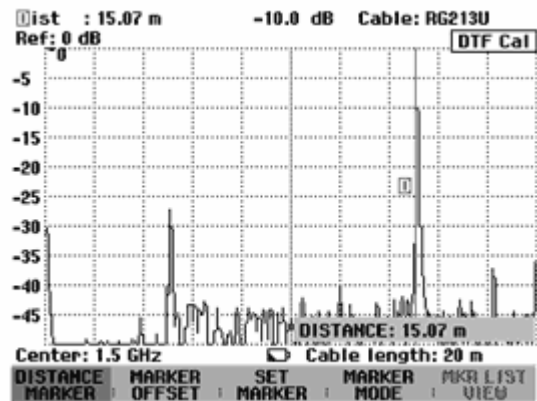

For higher fault resolution, the R&S FSH3-TV offers a zoom function in the position of the marker. The x axis of the display can be extended up to a span of 3 m.

- Press the MARKER MODE softkey.
- Using the rotary knob or the cursor keys, select ZOOM ON from the menu.
- Confirm with the ENTER key.

The entry field for the zoom factor is displayed while the R&S FSH3-TV simultaneously expands the x axis by a factor of 2.

- Using the rotary knob or the cursor keys, set the zoom factor to the value you want.

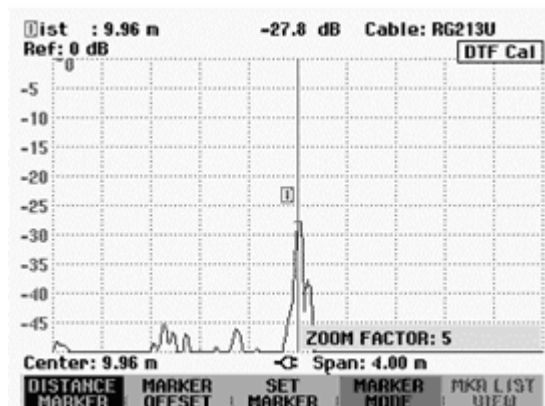

The screenshot on the right shows that the fault of the measured cable consists of two transitions. A coupling of approx. 7 cm in length was used to connect two cables.

Disable the zoom function as follows:

- Press the MARKER MODE softkey in the MARKER menu.
- Using the rotary knob or the cursor keys, select ZOOM OFF from the menu.
- Confirm by pressing the ENTER key or by pressing the MARKER MODE softkey again.

Checking the return loss of the cable under test:

- Press the MEAS MODE softkey.
- Select REFLECTION using the rotary knob or the cursor keys.
- Confirm by pressing the MEAS MODE softkey again or by pressing the ENTER key.



The R&S FSH3-TV measures the return loss over the span that has been selected for the distance-to-fault cable measurement.

To indicate that the R&S FSH3-TV is measuring return loss, **DTF refl. cal** is displayed in the upper right-hand corner of the screen.

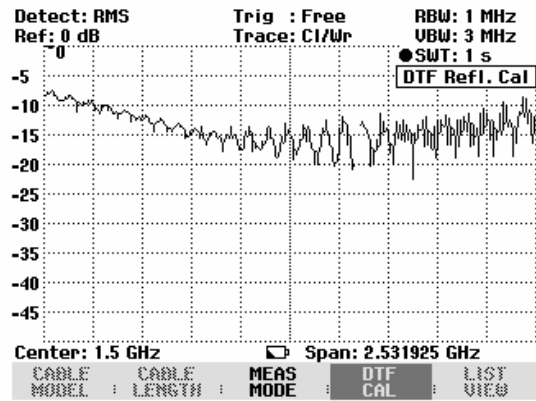

Checking the spectrum in the span for detecting external interferers:

- Press the MEAS MODE softkey.
- Using the rotary knob or cursor keys, select SPECTRUM.
- Confirm by pressing the MEAS MODE softkey again or by pressing the ENTER key.

The R&S FSH3-TV turns off the tracking generator and displays the spectrum over the span of the DTF measurement.

To indicate that the R&S FSH3-TV is in the spectrum mode, **DTF Spectrum** is displayed in the upper right-hand corner of the screen. Otherwise, the R&S FSH3-TV uses exactly the same settings as it did for DTF measurements.

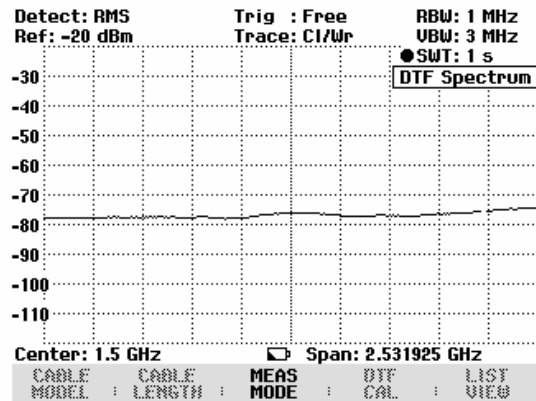

## Operation in Receiver Mode

(Available only if the option R&S FSH-K3 is installed.)

To provide a means of measuring levels at a specific frequency, the R&S FSH3-TV offers the receiver mode as an option (option R&S FSH-K3). With this option, the R&S FSH3-TV functions like a receiver that measures the level at a predefined frequency.

Switching on the receiver mode:

- Press the MEAS key.
- Press the MEASURE softkey.

The R&S FSH3-TV opens the menu for measurement functions.

- Using the cursor keys or the rotary knob, select RECEIVER and confirm with the ENTER key or MEASURE softkey.

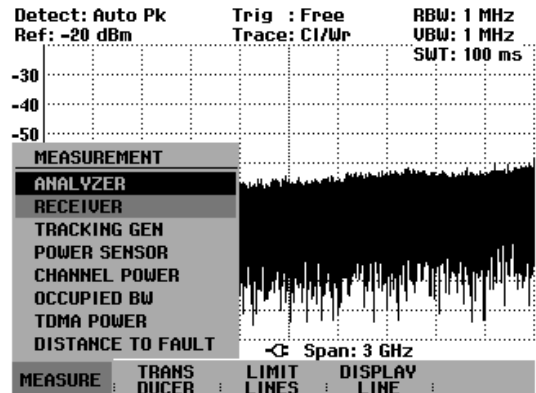

The R&S FSH3-TV activates the receiver mode and measures the level at the specified frequency.

The most important settings for the measurement parameters are provided directly in the main menu of the receiver mode, or they can be entered using the corresponding keys.

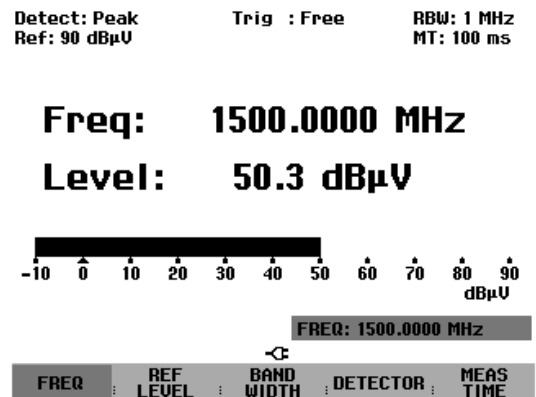

### Setting the frequency:

- Press the FREQ softkey in the main menu of the receiver mode.
- Using the rotary knob or the cursor keys, adjust the frequency, or, using the numeric keys, enter a new frequency and confirm the entry with the ENTER key.

You can also enter the frequency by using the FREQ key.

**Selecting the frequency step size:**

The frequency resolution in the receiver mode is 100 Hz. The tuned step size can be changed as required for the application

- Press the **FREQ** key.
- Press the **FREQ STEPSIZE** softkey.
- Set the required step size in the selection table.
- Confirm with the **ENTER** key.

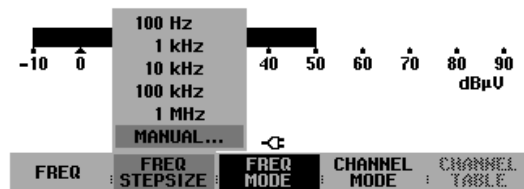

- You can set any step size you want by using **MANUAL....**
- To do so, select **MANUAL...** for the step size in the selection table.
- Using the rotary knob or cursor keys, change the tuned step size and confirm with the **ENTER** key, or, using the numeric keypad, manually enter a step size and confirm by pressing the units key.

**Tuning the frequency in channel grids:**

As an alternative to entering the frequency, the R&S FSH3-TV can also be tuned in channels. The channel tables that the R&S FSH3-TV uses to set channel frequencies are defined either by using the R&S FSH View software or by directly entering the first channel number, the associated frequency, the number of channels and the channel spacing.

- Press the **FREQ** key.
- Press the **CHANNEL MODE** softkey.

The R&S FSH3-TV now uses the active channel table. The **FREQ** softkey for frequency entry is renamed to **CHANNEL** for channel entry, and the R&S FSH3-TV displays the channel number instead of the frequency. The channel numbers are now used to tune the frequency.

Selecting a channel table that was predefined using R&S FSH View:

- If the channel display is active (**CHANNEL MODE** softkey active in the **FREQ** menu), press the **CHANNEL TABLE** softkey.

The R&S FSH3-TV will display the stored channel tables.

- Using the rotary knob or cursor keys, select the channel table you want.
- To activate the channel table, press the **SELECT** softkey.

01/04/2004	BAND TABLE LIST	22:40:09
TU France	01/03/2004 15:59:02	
TU Japan	01/03/2004 14:58:52	
TU DK_DIRT	01/03/2004 14:40:20	
TU Australia	01/03/2004 14:40:08	
TU Europe	01/03/2004 14:39:56	
TU China	01/03/2004 14:34:40	
TU Italy	01/03/2004 14:30:40	
TU Ireland	01/03/2004 14:30:26	
TU French Overs	01/03/2004 14:30:16	
PCS UL	01/01/1995 02:00:00	
PCS DL	01/01/1995 02:00:00	
GSM UL	01/01/1995 02:00:00	
GSM DL	01/01/1995 02:00:00	



Direct entry of a channel table:

- If the channel display is active (CHANNEL MODE softkey active in the FREQ menu), press the CHANNEL TABLE softkey.
- Press the SELECT USER TAB softkey.

The R&S FSH3-TV will use the last channel table that was entered directly.

- Press the DEFINE USER TAB softkey.

The R&S FSH3-TV will open the submenu for defining the channel table.

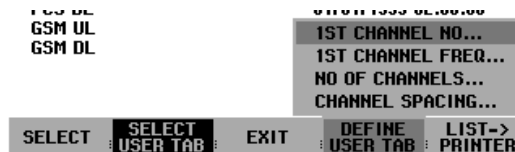

- Press the DEFINE USER TAB softkey again.
- Enter the number of the first channel and confirm with the ENTER key.
- Press the DEFINE USER TAB softkey.
- Using the rotary knob or the cursor keys, select 1ST CHANNEL FREQ... from the menu and confirm with the ENTER key.
- Enter the frequency for the first channel number.
- Press the DEFINE USER TAB softkey.
- Using the rotary knob or the cursor keys, select NO OF CHANNELS... from the menu and confirm with the ENTER key.
- Enter the number of channels and confirm with the ENTER key.
- Press the DEFINE USER TAB softkey.
- Using the rotary knob or the cursor keys, select CHANNEL SPACING... from the menu and confirm with the ENTER key.
- Enter the frequency spacing for the channels and confirm with the ENTER key.
- Press the EXIT key to exit the menu for defining channel tables.

The R&S FSH3-TV will now show channel numbers instead of the frequency. It also shows the associated frequency above Channel.

**Selecting the reference level:**

The reference level is the maximum level of the analog bar-graph display. It must be set in such a way that the level display is located within the bar-graph scale.

- Press the REF LEVEL softkey in the main menu of the receiver mode (MEAS key). Or press the AMPT key.
- Using the rotary knob or cursor keys, change the reference level or, using the numeric keys, enter a new reference level.
- Confirm with the ENTER key.

**Selecting the bandwidth:**

The receiver mode provides the same bandwidths as in analyzer operation. In addition, the three bandwidths 200 Hz, 9 kHz and 120 kHz are available for EMI measurements in accordance with CISPR16.

- Press the BW key
- Using the rotary knob or cursor keys, enter the bandwidth you want and confirm by pressing the unit key.
- For input of a CISPR bandwidth press the softkey CISPR BW.
- Using the rotary knob or cursor keys, change the bandwidth and confirm with the ENTER key, or, using the numeric keypad, manually enter bandwidth and confirm by pressing the unit key.

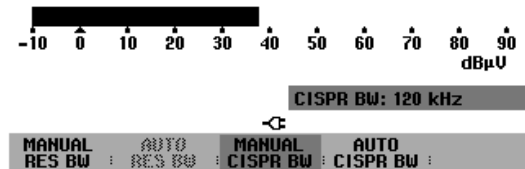

According to CISPR16 the bandwidth is connected to the frequency. The R&S FSH3-TV allows to couple the bandwidth to the set frequency automatically:

- Press the softkey AUTO CISPPR BW.

The R&S FSH3-TV uses the suitable bandwidth dependent on the set frequency.

**Setting the detector:**

The receiver mode of the R&S FSH3-TV offers a peak detector, average detector, RMS detector and quasi-peak detector.

Set the detector either from the main menu of the receiver mode or by using the TRACE key.

- Press the DETECTOR softkey in the main menu of the receiver mode, or press first the TRACE key and then the DETECTOR softkey
- Using the rotary knob or cursor keys, select a detector from the selection list.
- Press the ENTER softkey.

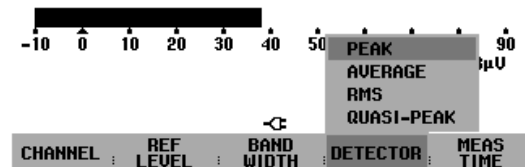

**Setting the measurement time:**

The measurement time is the amount of time during which the R&S FSH3-TV collects measured values and compiles them into a display result for the selected detector.

- Press the MEAS TIME softkey in the main menu of the receiver mode, or press the SWEEP key.
- Using the rotary knob or cursor keys, adjust the measurement time, or, using the numeric keys, enter a new measurement time and confirm with the unit.

*Note: If the quasi-peak detector is selected, the selected measurement time must be larger than 100 ms in order to ensure that fluctuating or pulse-like signals are measured correctly.*

**Scanning in the receiver mode:**

In the receiver mode, the R&S FSH3-TV can scan across a defined number of frequencies and graphically display the results. It performs a measurement at each frequency for the defined measurement time.

- Press the SPAN softkey.
- Press the FREQ SCAN softkey.

The R&S FSH3-TV switches to the scan mode and displays the measurement levels at the individual frequencies as vertical lines.

- Press the SCAN START softkey.
- Enter the start frequency for the scan.
- Press the SCAN STOP softkey.
- Enter the stop frequency for the scan.
- Press the SCAN STEP softkey.
- Enter the step size for the scan.

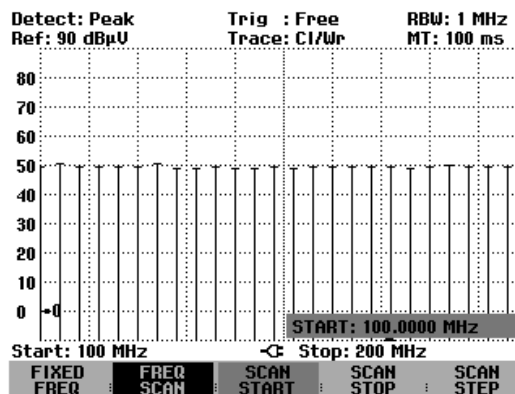

It is also possible to scan the frequencies of a channel table. This requires activating a channel table as follows:

- Press the FREQ softkey.
- Press the CHANNEL MODE softkey.

The R&S FSH3-TV now performs a measurement at the frequencies of the channel table.

## Saving and Recalling Settings and Test Results

Instrument settings and results can be saved to the R&S FSH3-TV's internal CMOS RAM. Results and settings are always stored together, allowing them to be interpreted in context when recalled. The R&S FSH3-TV can store a maximum of 100 data sets, each with a unique name.

### Saving Measurement Results

- Press the SAVE / PRINT key.
- Press the SAVE softkey.

An input box opens and you will be prompted to enter a name for the data set to be saved.

The name for the most recently stored data set is suggested in the 'Name:' entry box, which is highlighted in red. When you press the ENTER key or the SAVE softkey a second time, the data set is saved under the suggested name.

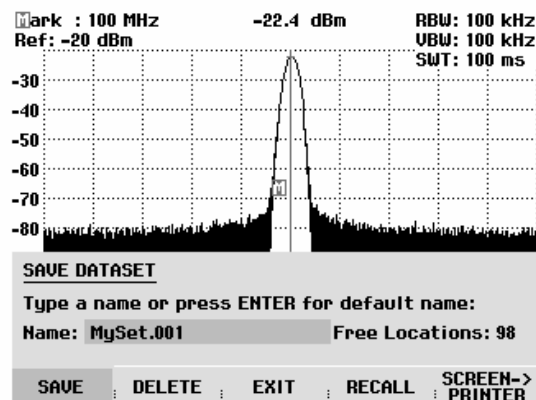

By pressing the BACK key, you can instruct the R&S FSH3-TV to browse through the list of names of the data sets already stored and display them with the first available free extension. Thus, the name of the data set recalled for a specific measurement can be selected for storing the measurement data.

A new name can be entered via the numeric keypad. The numeric keypad has the same letter assignment as mobile phone keypads. Enter the letter above the key by pressing the key the appropriate number of times.

The number of free memory locations is also displayed.

- Enter a name for the data set using the numeric keypad.
- Confirm with ENTER.

The data set is saved to the R&S FSH3-TV's internal memory under the specified name.

The name of an existing data set can be edited with the cursor keys. It is therefore not necessary to fully enter the name of a new data set.

- Press the SAVE key.

The R&S FSH3-TV suggests a name for the data set to be saved.

- Press a cursor key (⤴ or ⤵).

A vertical cursor is positioned at the end of the name for the data set.

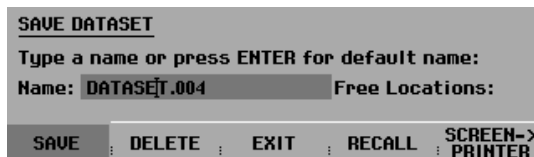

- Use the ⤵ key to move the cursor to the left.
- Use the ⤴ key to move the cursor to the right.
- Insert a new letter or number at the cursor position using the alphanumeric keypad.
- Press the BACK key to delete the letter or digit to the left of the cursor.

## Saving Calibration Data

When performing scalar transmission or return loss measurements, the R&S FSH3-TV can store the calibration data along with the settings and results. Saving the settings and results with calibration data requires twice as much memory space as without it. This, of course, reduces the maximum number of data sets that can be saved.

In the default state, calibration data storage is disabled.

- Press the SETUP key.
- Press the GENERAL softkey.
- Select SAVE CAL DATA... and confirm by pressing the ENTER key or the GENERAL softkey.
- Using the rotary knob or the cursor keys, select ON or OFF.
- Confirm with ENTER.

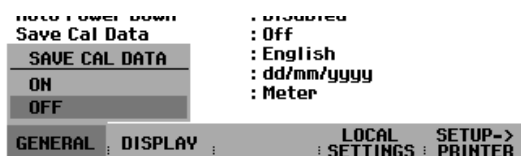

The state for calibration data saving is entered in the SETUP menu.

When recalling data sets with stored calibration data, the R&S FSH3-TV checks whether the current instrument temperature corresponds to the instrument temperature at the time the data was stored. If there is a deviation, the R&S FSH3-TV displays a red dot in front of the • Transmission or • Reflection display. Recalibration is then necessary.



## Recalling Measurement Results

Use the R&S FSH3-TV's recall function to review previously saved measurement results and settings.

- Press the SAVE / PRINT key.
- Press the RECALL softkey.

A list of all saved data sets opens. The red selection bar marks the last data set to be saved.

09/12/2002	DATASET LIST	17:08:48
MySet.000	09/12/2002 17:04:54	
rs.001	06/03/2002 10:43:24	
rs.000	01/03/2002 12:10:43	

- Select a data set from the list using the rotary knob.
- Confirm your selection by pressing the RECALL softkey.

The selected data set is displayed on the screen, but the R&S FSH3-TV is not set to the settings in the data set. You can now check the data set before its settings are activated.

DELETE ALL	DELETE	EXIT	RECALL	LIST-> PRINTER
------------	--------	------	--------	----------------

The name of the selected data set is displayed at the lower left-hand corner of the screen. Using the rotary knob or the cursor keys, you can scroll through all the available data sets. The settings and results for each data set are displayed.

You now have the following options:

- Press the STATUS key to see all the instrument settings in the selected data set. When you press the STATUS key again, the R&S FSH3-TV returns to the graphical display.
- Press the ACTIVATE softkey to load the data set.
- Press the EXIT softkey to display the list of data sets again. Press EXIT a second time and the R&S FSH3-TV returns to its previous settings without loading a data set.
- Press SCREEN->PRINTER to send the displayed data set to a printer.

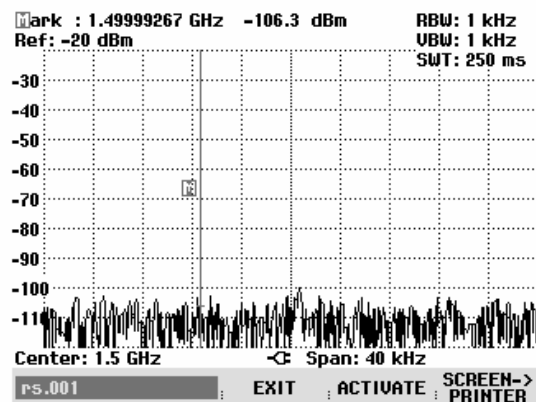

Pressing the ACTIVATE softkey transfers the stored trace to the R&S FSH3-TV's trace memory. The current trace can be compared with the stored one by switching on the trace memory.

- Press the TRACE key.
- Press the SHOW MEMORY softkey.

The R&S FSH3-TV displays the stored trace in white and the current trace in yellow.

*Note: The trace is in the R&S FSH3-TV's trace memory. The level and frequency values are displayed correctly only if neither the instrument's frequency setting nor its level setting has been changed.*

## Printing Out Measurement Results

The R&S FSH3-TV can send screenshots to a printer equipped with a serial interface. The type of printer and the baud rate of the serial interface can be defined in the setup menu (SETUP key) by using the GENERAL softkey and selecting 'PRINTER BAUD...' and 'PRINTER TYPE...' from the menu. For printers with a parallel interface, a serial/parallel converter (R&S FSH-Z22) is available.

### Printer with serial interface:

- Connect the printer to the optical interface of the R&S FSH3-TV using the RS-232-C optical interface cable.

### Printer with parallel interface:

- Connect the RS-232-C optical interface cable to the Serial/Parallel Converter R&S FSH-Z22.
- Connect the R&S FSH-Z22 parallel interface to the printer.
- Switch on the Serial/Parallel Converter R&S FSH-Z22

### Operating the R&S FSH3-TV:

- Press the SAVE / PRINT key.

The SAVE/PRINT menu with the option for printing out a screenshot to a printer opens.

- Press the SCREEN->PRINTER softkey.

The R&S FSH3-TV starts printing out the screenshot to a printer.

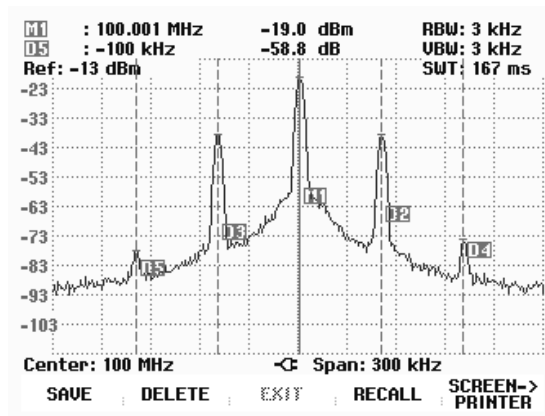

### 3 Operation and menu overview

#### Entering Parameters

Settings and texts are entered either by directly calling the functions or by entering values, units or texts separately. The R&S FSH has a variety of operating modes.

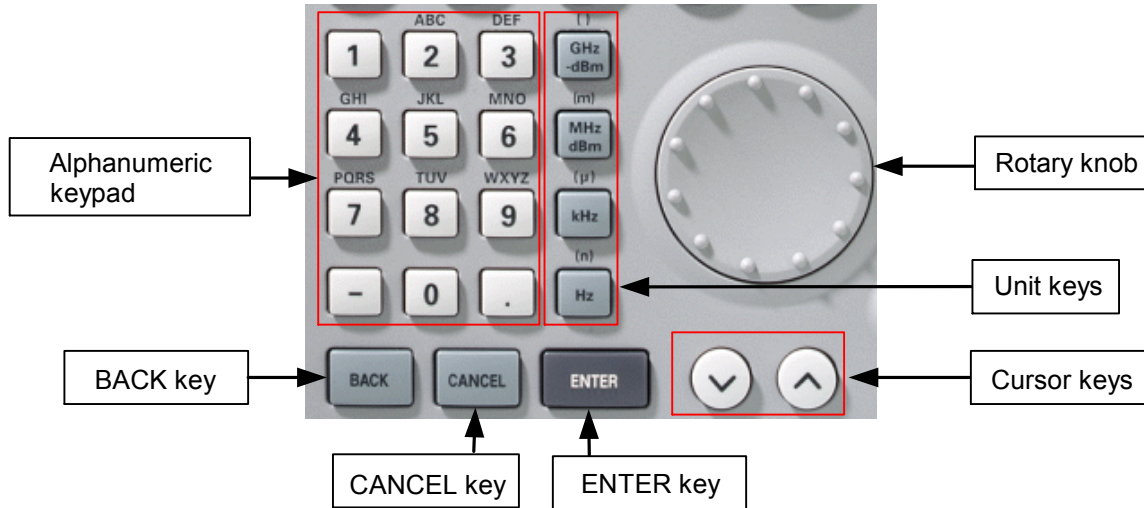

#### Entering values and texts

Values are entered using the number keys (0 to 9), the decimal point key (.) and the minus key (-) in the alphanumeric keypad. The alphanumeric keypad is also used to enter letters, e.g. file names for data sets. If the R&S FSH is expecting a letter entry, it automatically assigns the letters above the keys to the keys in the alphanumeric keypad. The keys have multiple assignments. The letter you want is obtained by pressing the key the appropriate number of times. The key assignments are listed below:

Key	x1	x2	x3	x4	x5	x6	x7	x8	x9
1	1								
2	a	b	c	2	A	B	C		
3	d	e	f	3	D	E	F		
4	g	h	i	4	G	H	I		
5	j	k	l	5	J	K	L		
6	m	n	o	6	M	N	O		
7	p	q	r	s	7	P	Q	R	S
8	t	u	v	8	T	U	V		
9	w	x	y	z	9	W	X	Y	Z
-	-								
0	0	SPC	_						
.	.								

You can delete any letter or digit you have entered with the BACK key. Pressing the BACK key deletes the last keystroke that has been entered. Complete entries can be cancelled with the CANCEL key.

Values can also be entered with the rotary knob or the cursor keys. The entry is changed in steps and the R&S FSH immediately sets the appropriate entry parameter.

## Entering units

To enter a unit for a value entry, terminate the entry with a unit key. Use the unit keys down the right-hand side of the alphanumeric keypad. These keys have multiple assignments which depend on the unit entry expected by the R&S FSH.



( ) GHz, -dBm, V, s



(m) MHz, dBm, dBmV, mV, ms



(μ) kHz, dBμV, μV, μs



(n) kHz, nV, ns

The relative unit dB can be entered with any of the unit keys.

# Menu Overview

## Instrument setup

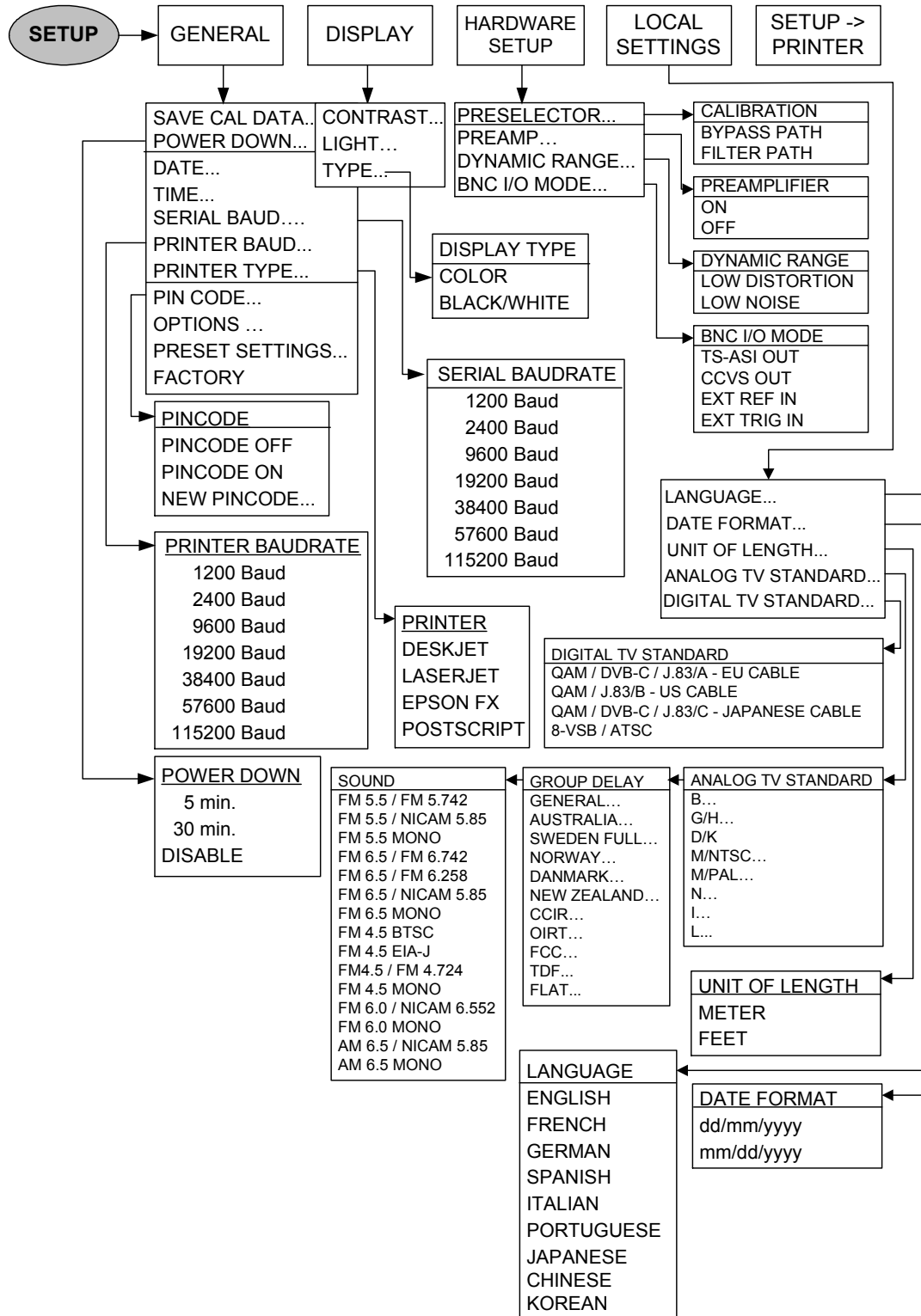

### Status display

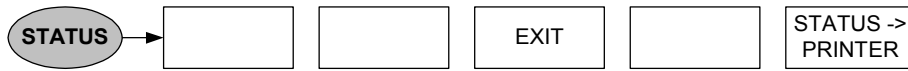

### Save and print-menu

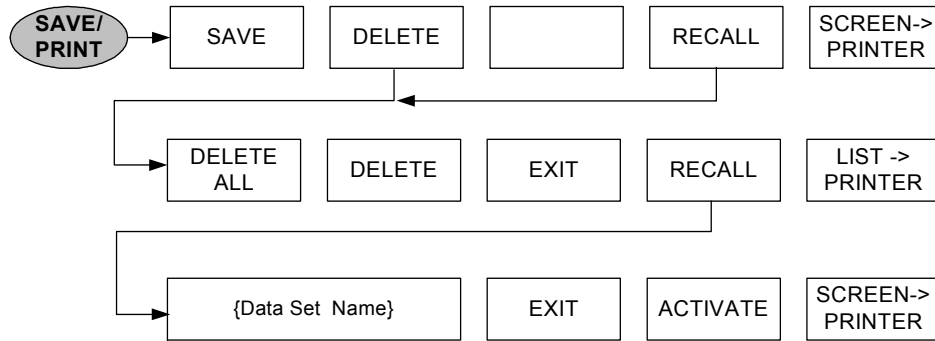

### Limit line menus

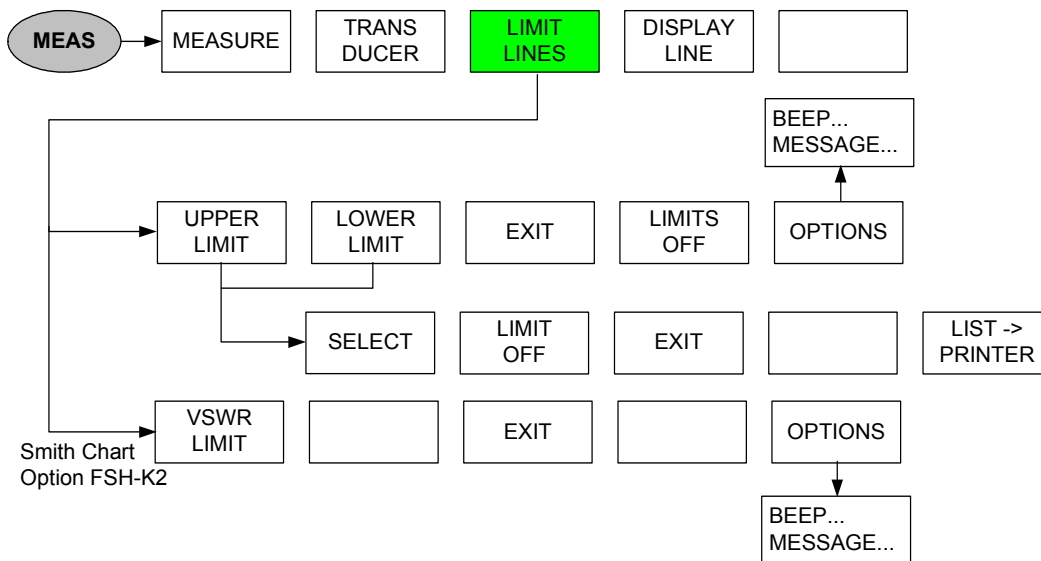

### Transducer menus

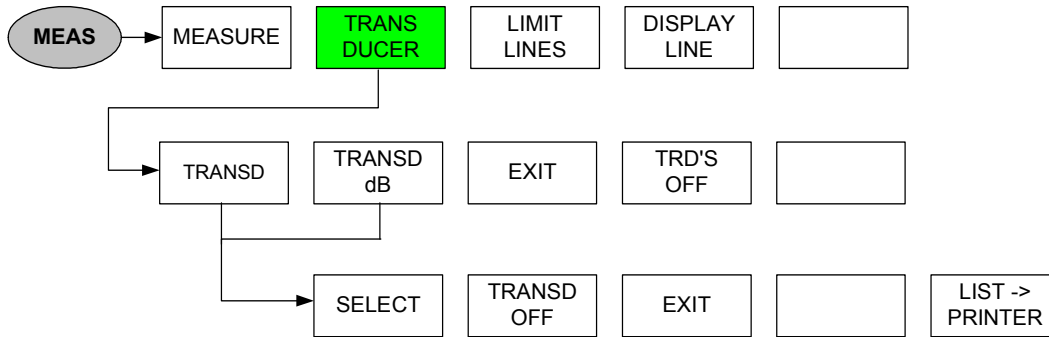

### Spectrum analyzer

#### Frequency entry

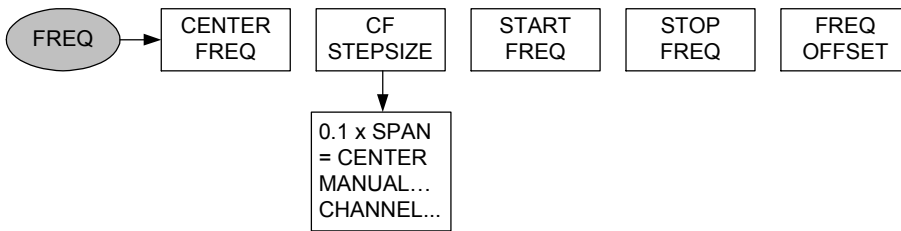

#### Frequency span entry

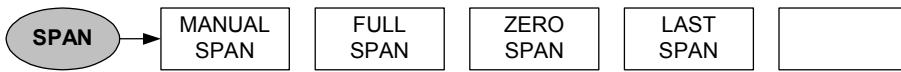

#### Level entry

##### Analyzer mode:

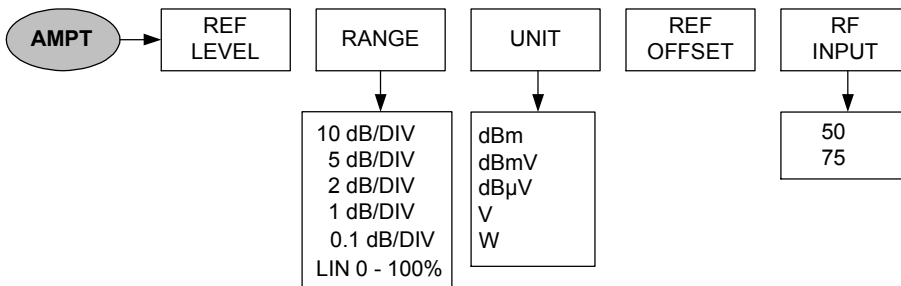



Tracking generator mode:

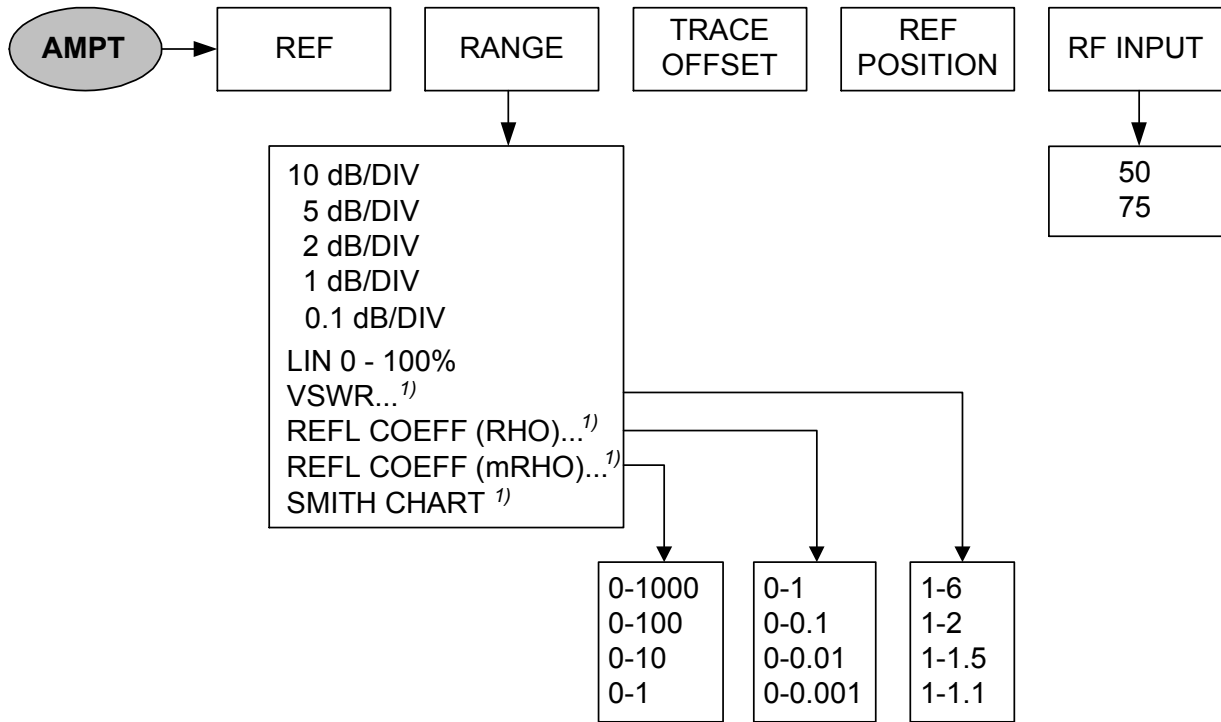

<sup>1)</sup> only with option R&S FSH-K2.

Bandwidth entry



Sweep entry

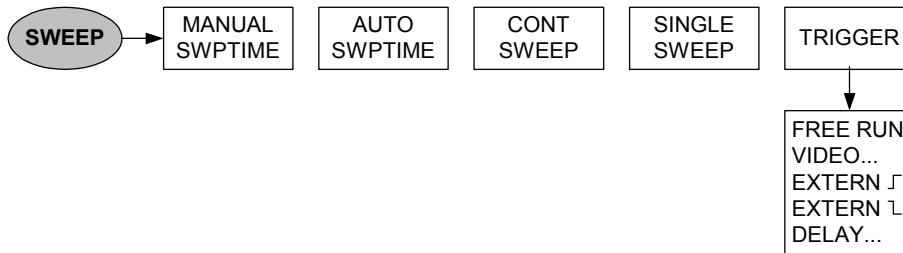

**Trace settings**

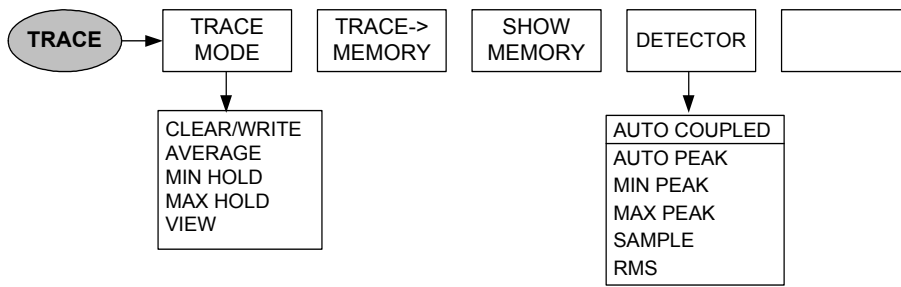

**Markers**

**Analyzer mode:**

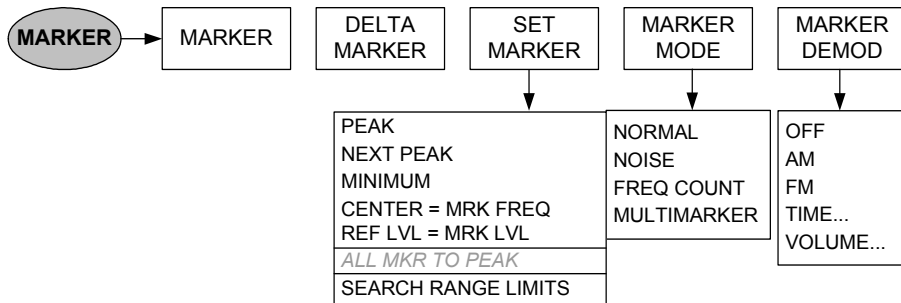

**Analyzer mode, multimarker switched on:**

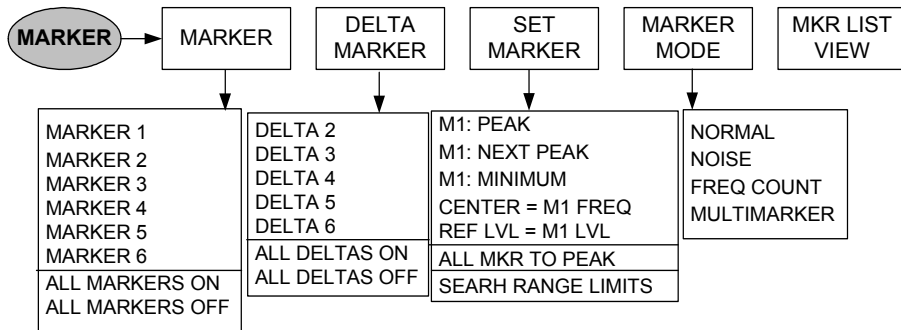

**Distance-to-fault mode (option R&S FSH-B1):**

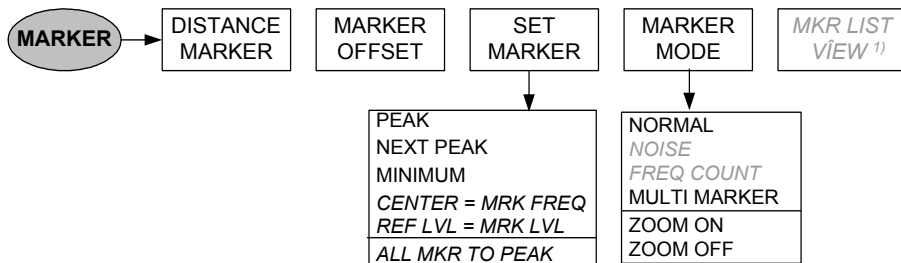

1) Only with multimarker switched on.

Distance-to-fault mode (option R&S FSH-B1), multimarker switched on:

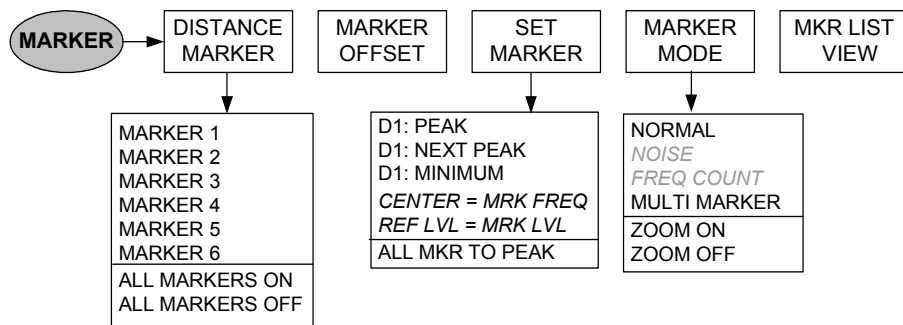

# Analog TV receiver

Main menu (part 1):

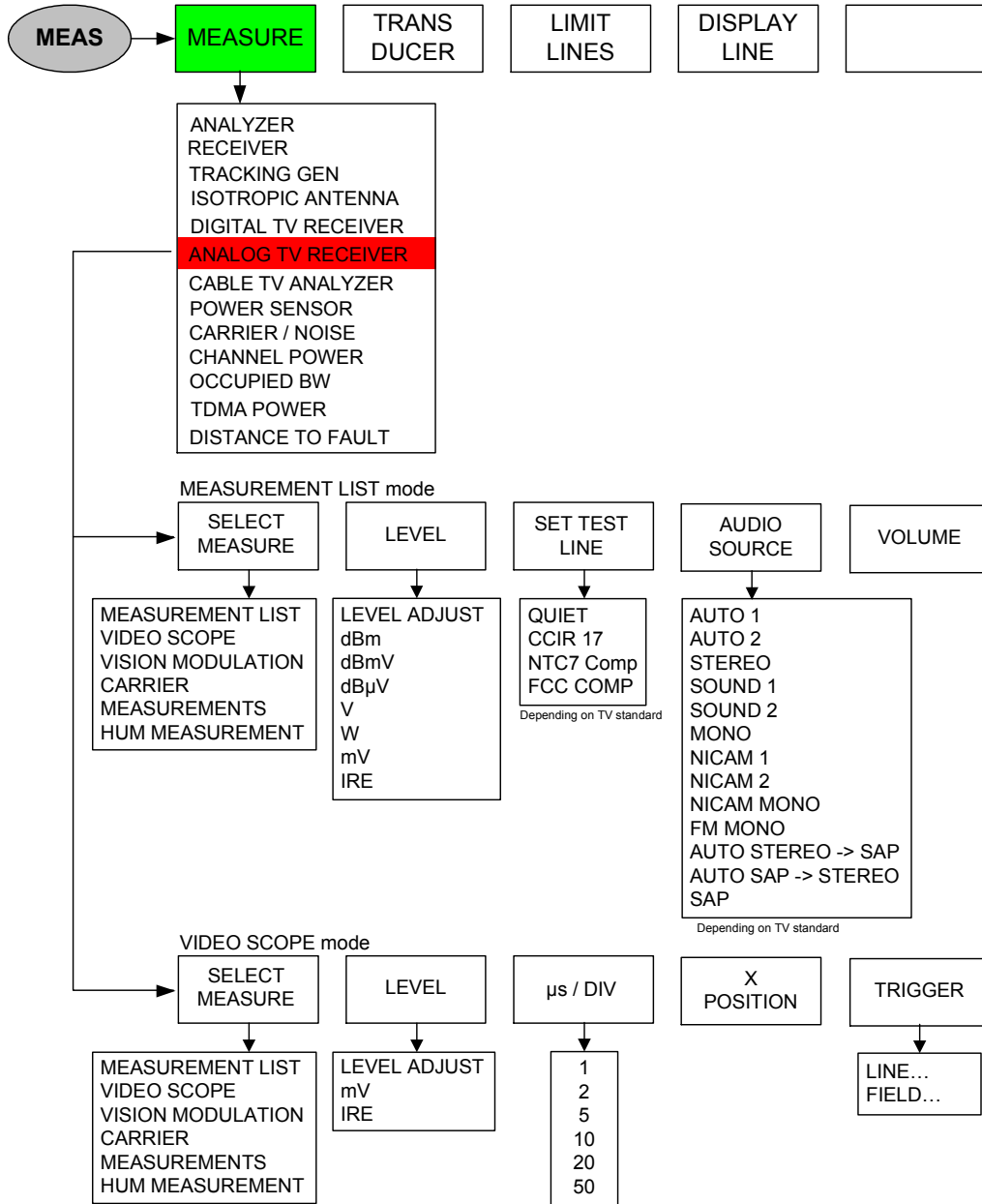

Main menu (part 2):

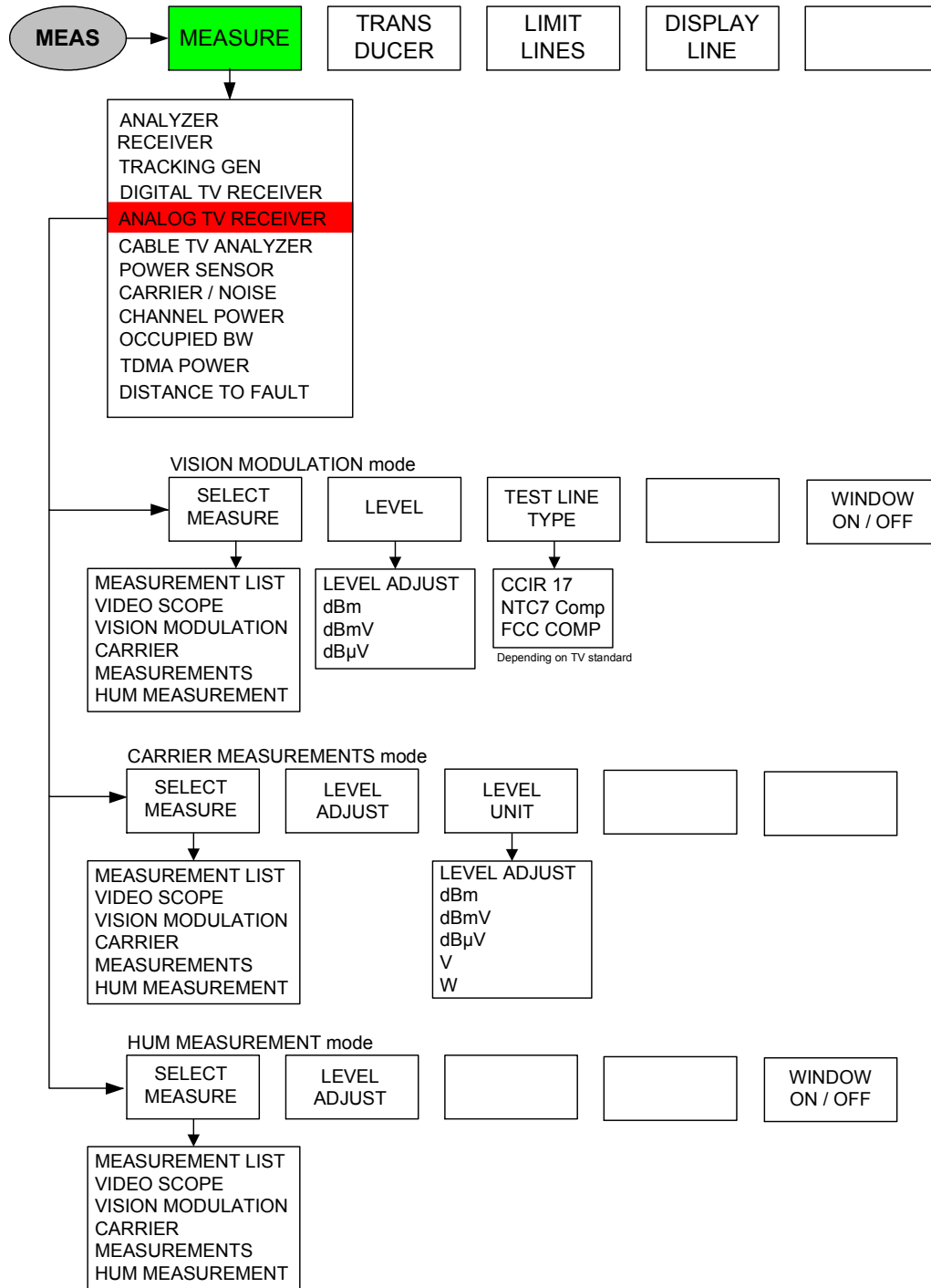

**FREQ key**



**AMPT key**

Measurement List, Video Scope and Carrier Measurements modes:

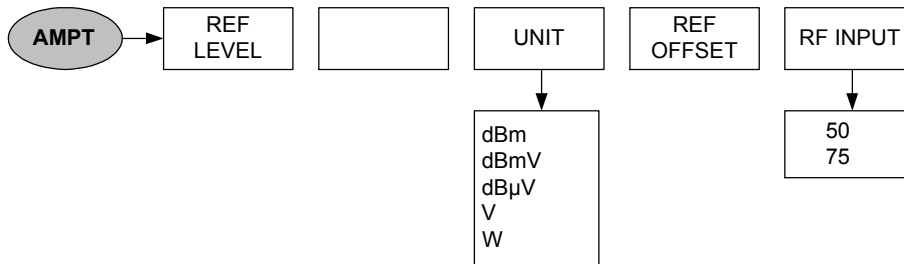

Vision Modulation and Hum Measurement modes:

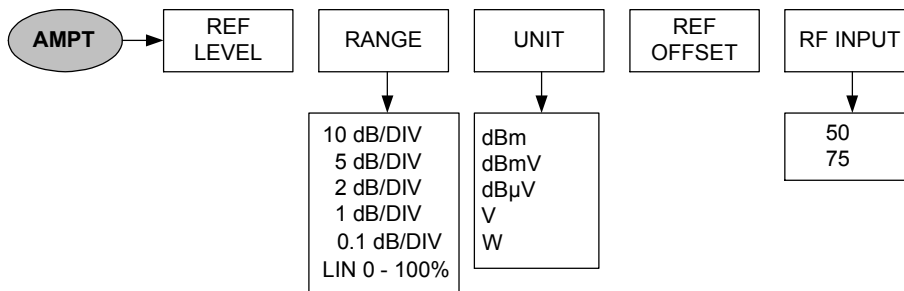

**BW key**

Measurement List, Video Scope, Vision Modulation and Carrier Measurements modes:

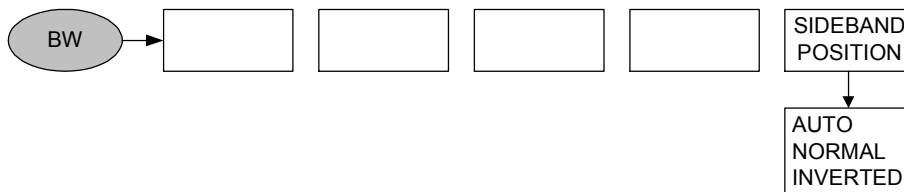

Hum Measurement mode:

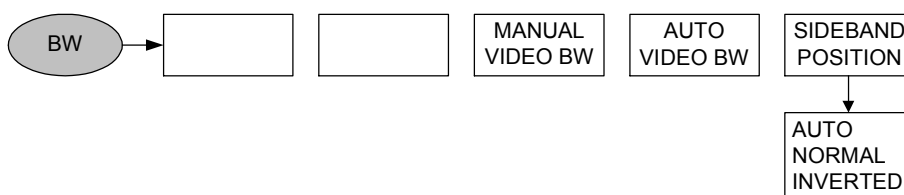

**SWEEP key**

**Video Scope mode:**

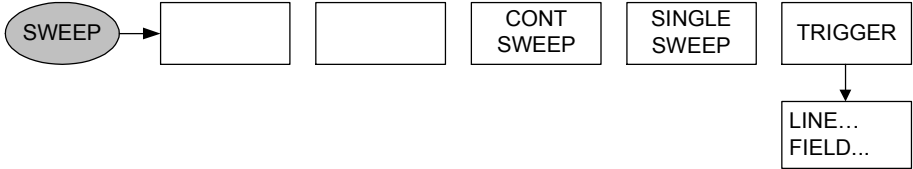

**Vision Modulation mode:**

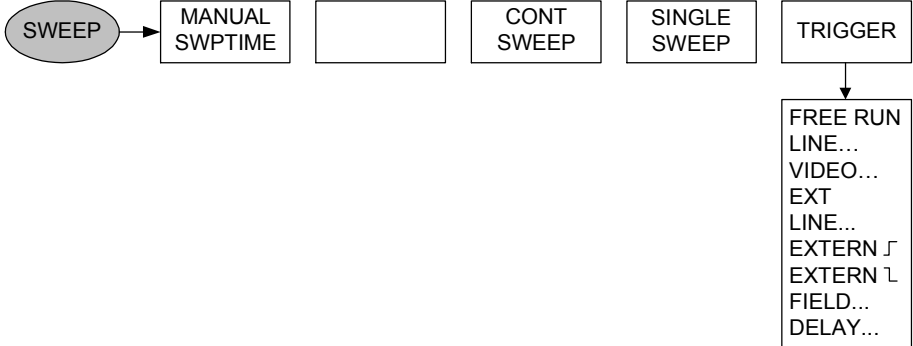

**Hum Measurement mode:**

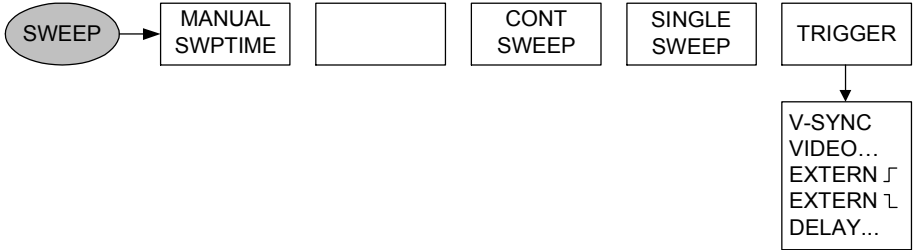

**TRACE key**

**Video Scope mode:**

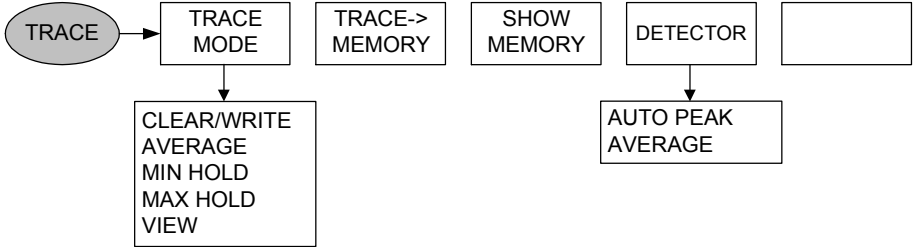

**Vision Modulation mode:**

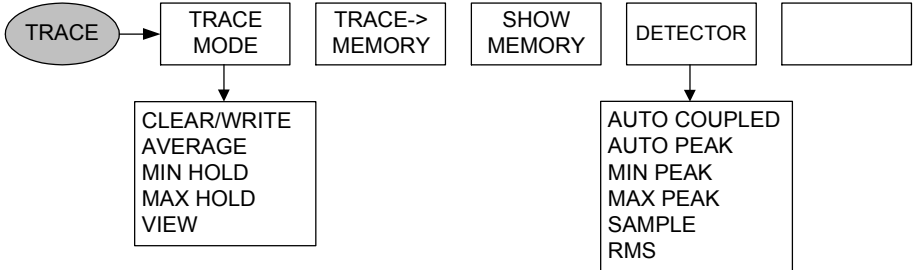

**Hum Measurement mode:**

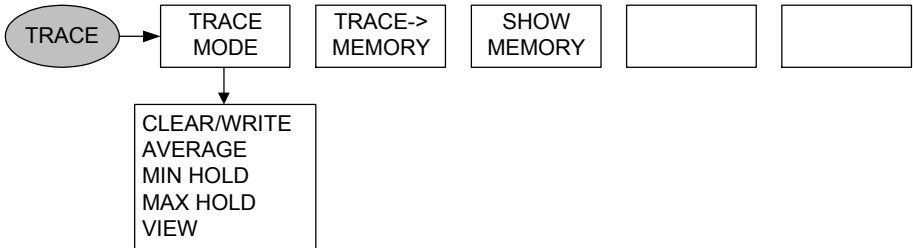



**MARKER key**

**Video Scope mode:**

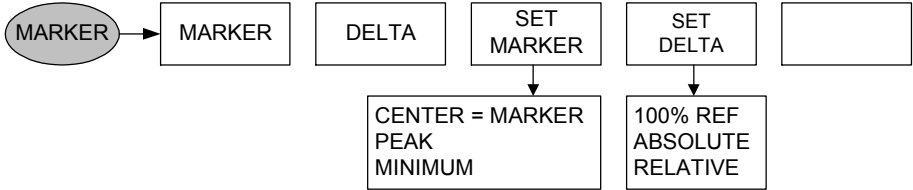

**Vision Modulation mode:**

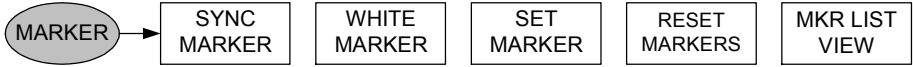

**Hum Measurement mode:**

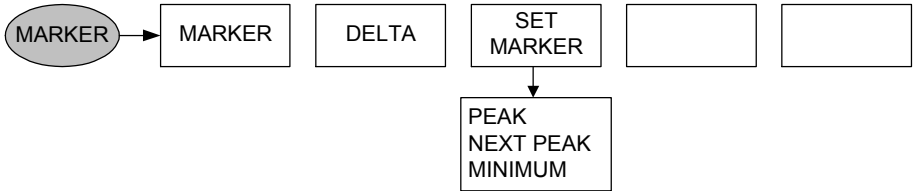

### Digital TV receiver (options R&S FSHTV-K21, R&S FSHTV-K22)

Main menu:

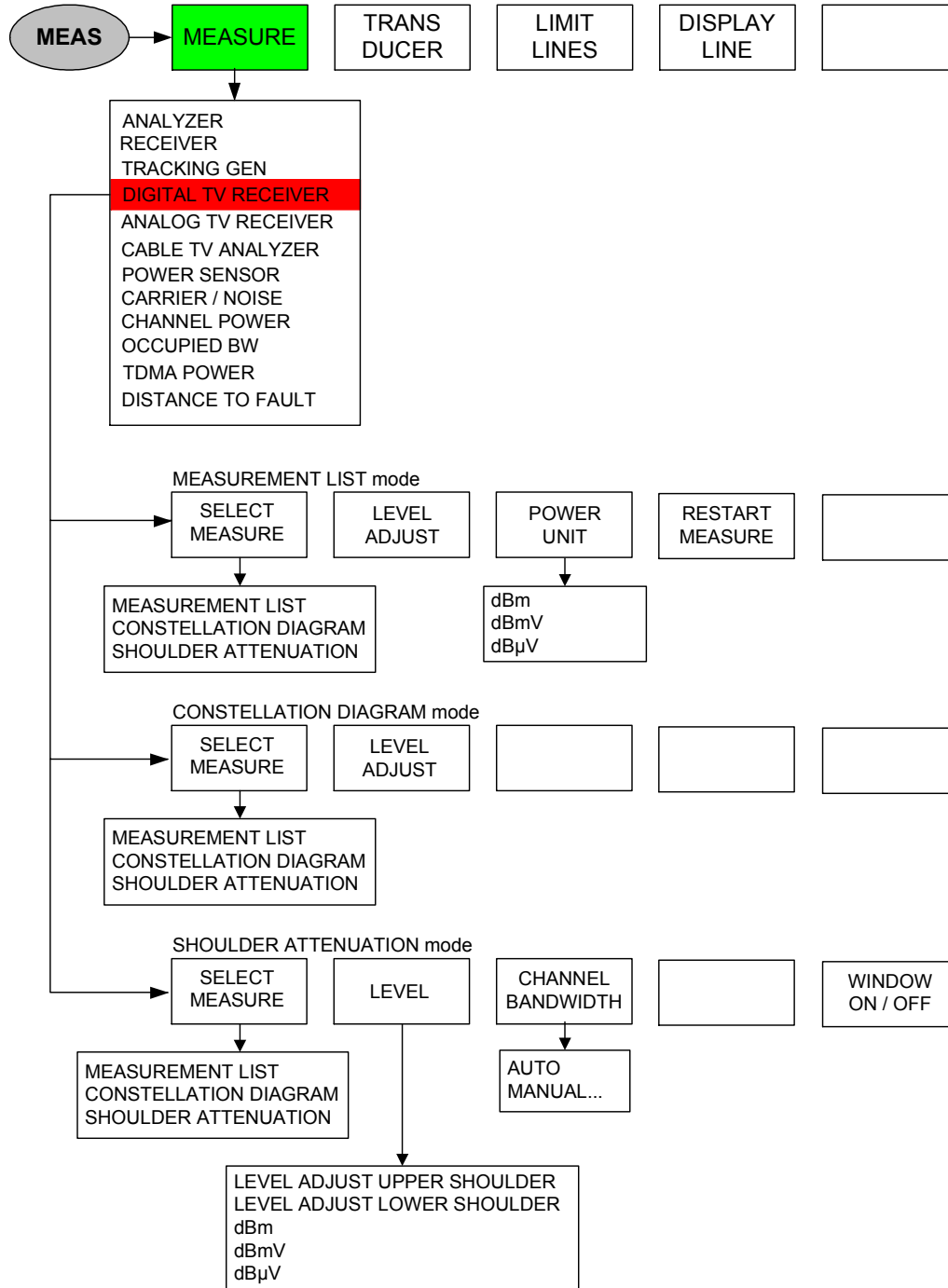

**FREQ key**



**SPAN key**

**Shoulder Attenuation mode:**

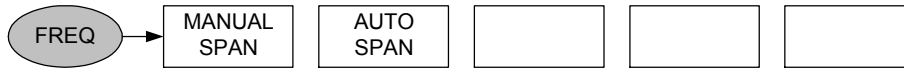

**AMPT key**

**Measurement List and Constellation Diagram modes:**

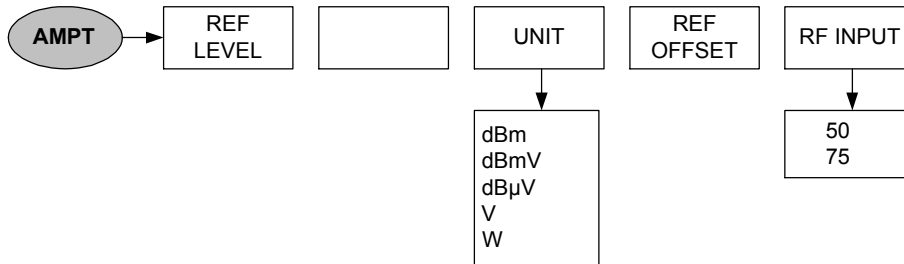

**Shoulder Attenuation mode:**

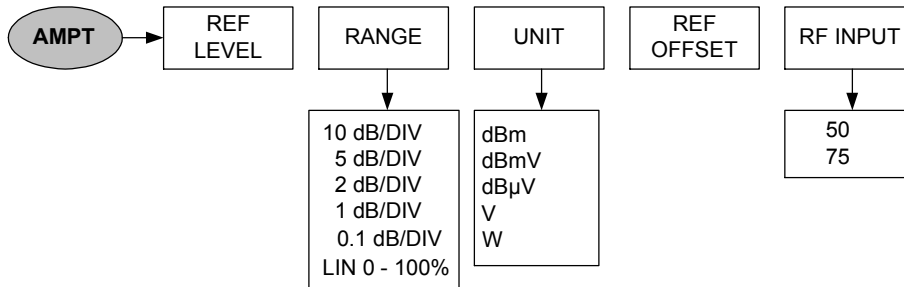

**BW key**

**Measurement List and Constellation Diagram modes:**

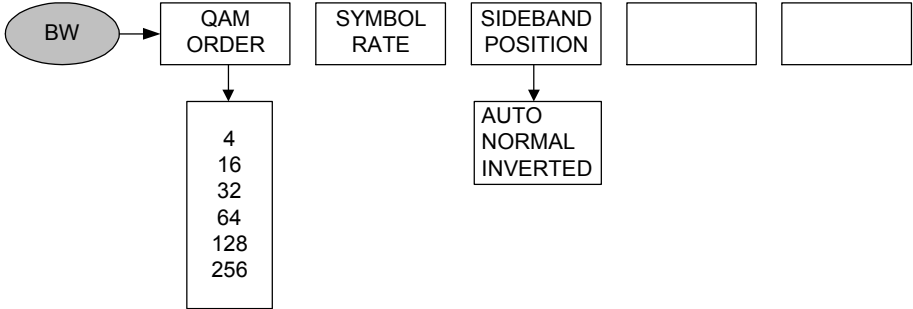

**Shoulder Attenuation mode:**

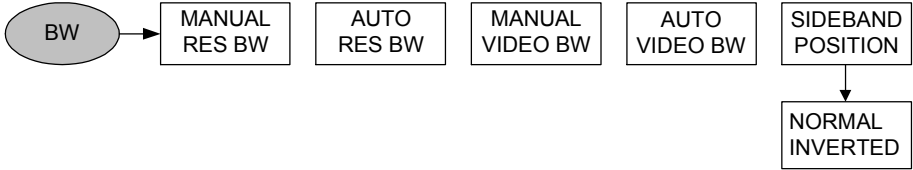

**SWEEP key**

**Shoulder Attenuation mode:**

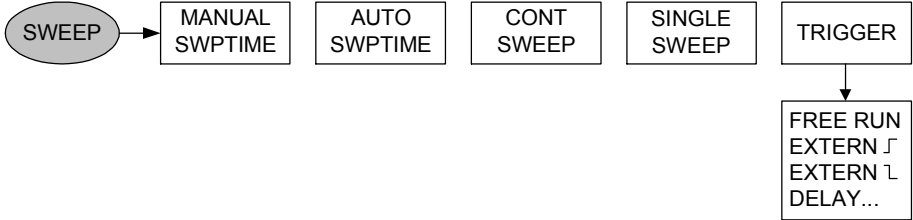

**TRACE key**

**Constellation Diagram mode:**



**Shoulder Attenuation mode:**

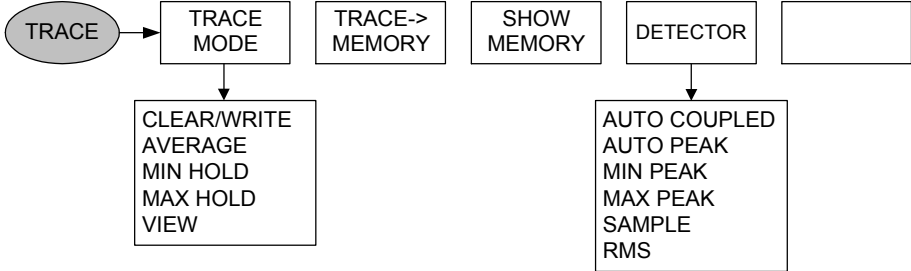

# Cable-TV analyzer

CTB mode:

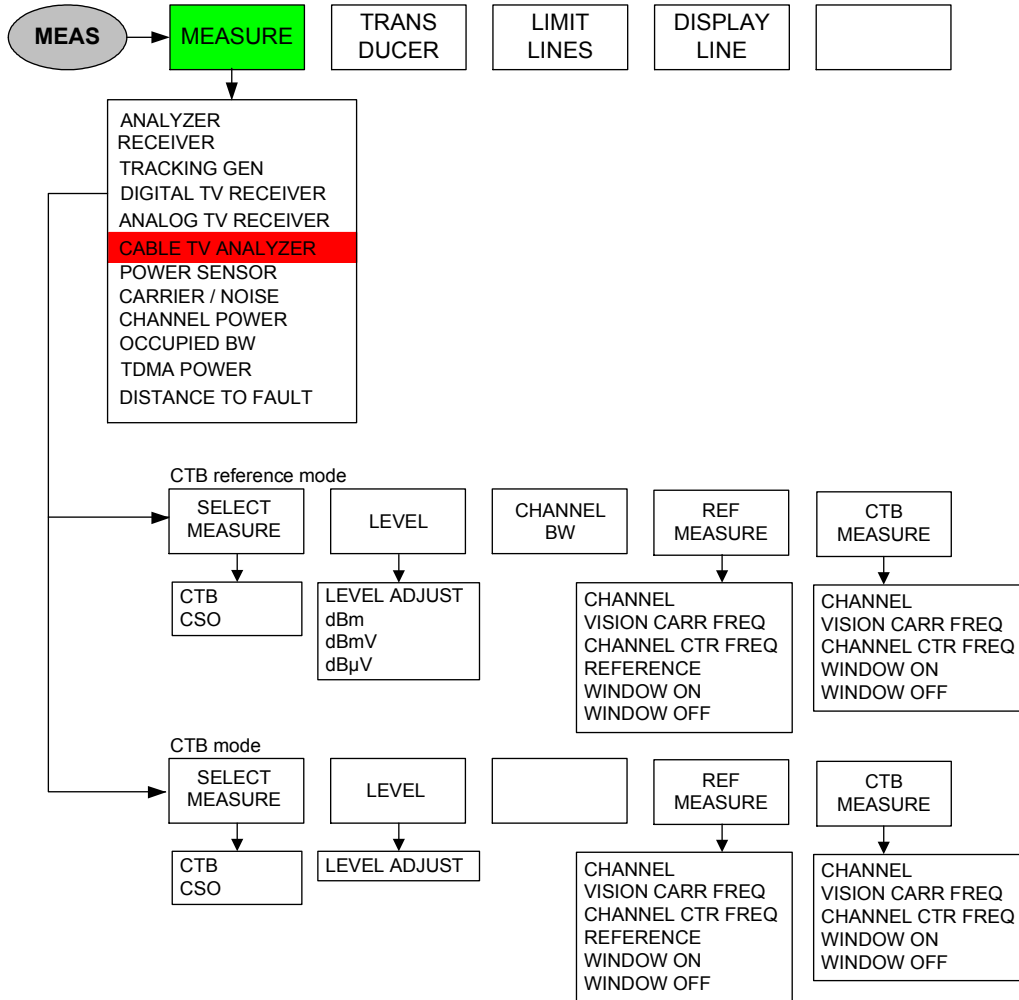

CSO mode:

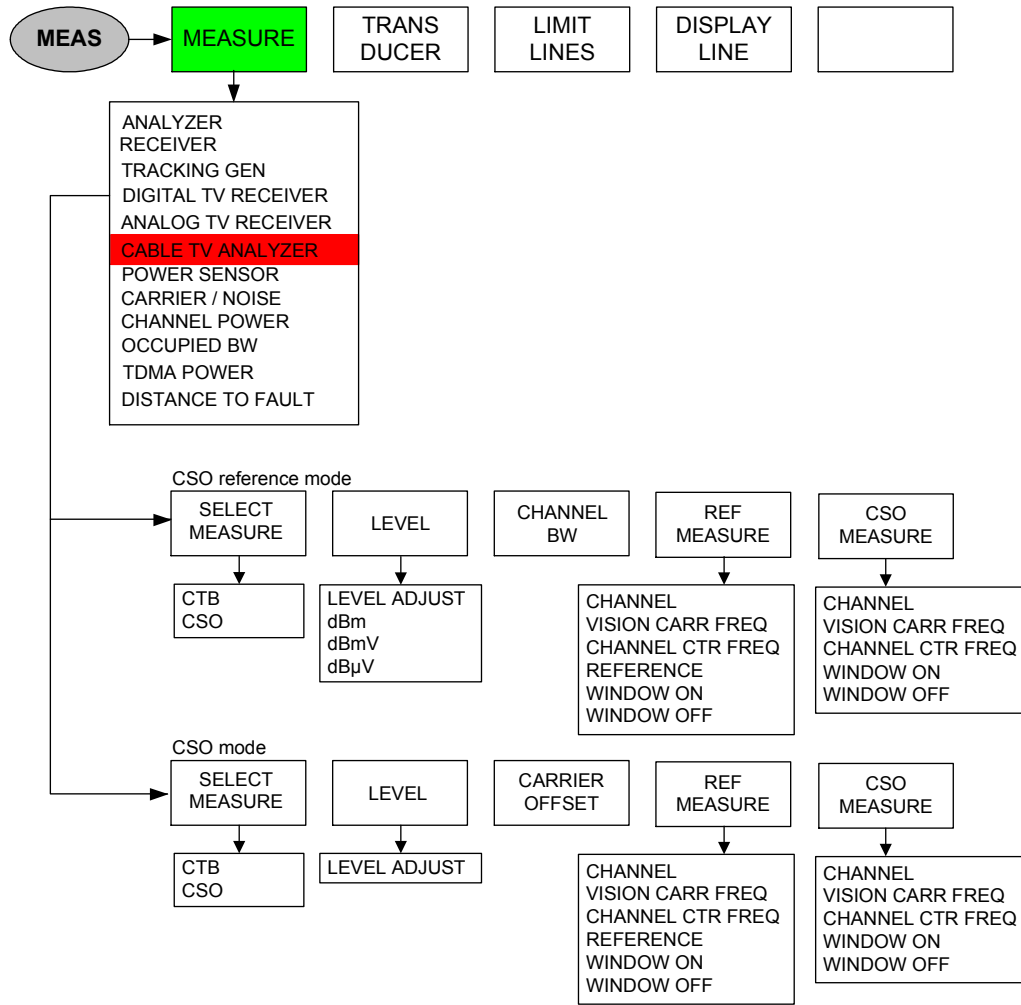

FREQ key



SPAN key



**AMPT key**

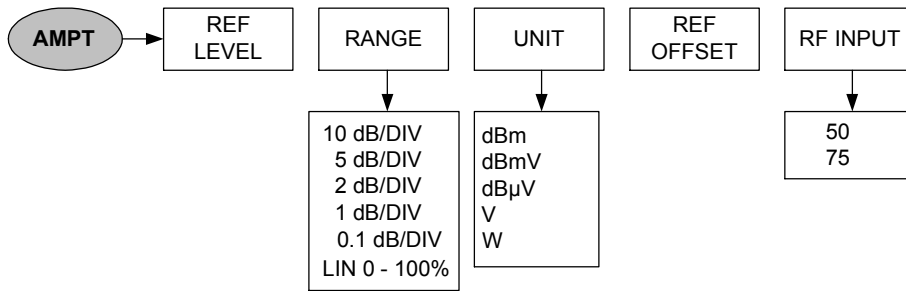

**BW key**

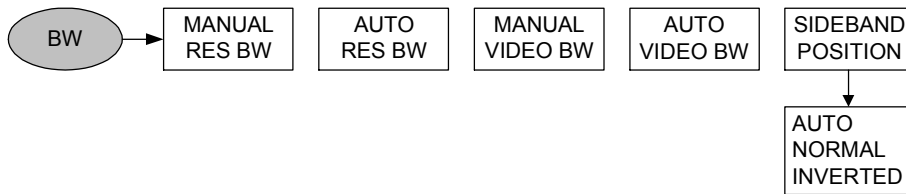

**SWEEP key**



**TRACE key**

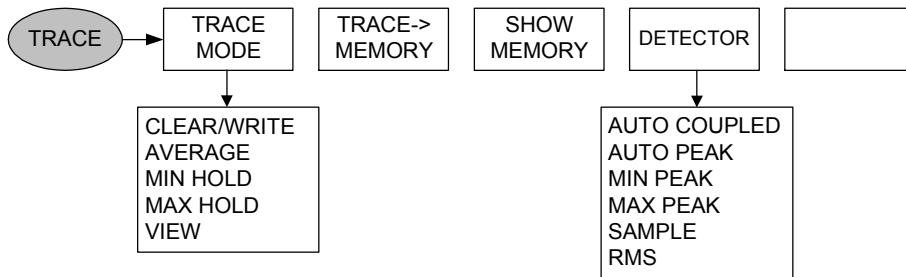

**MARKER key**

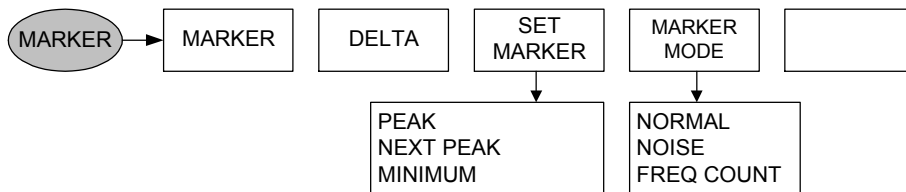



### Measurement functions

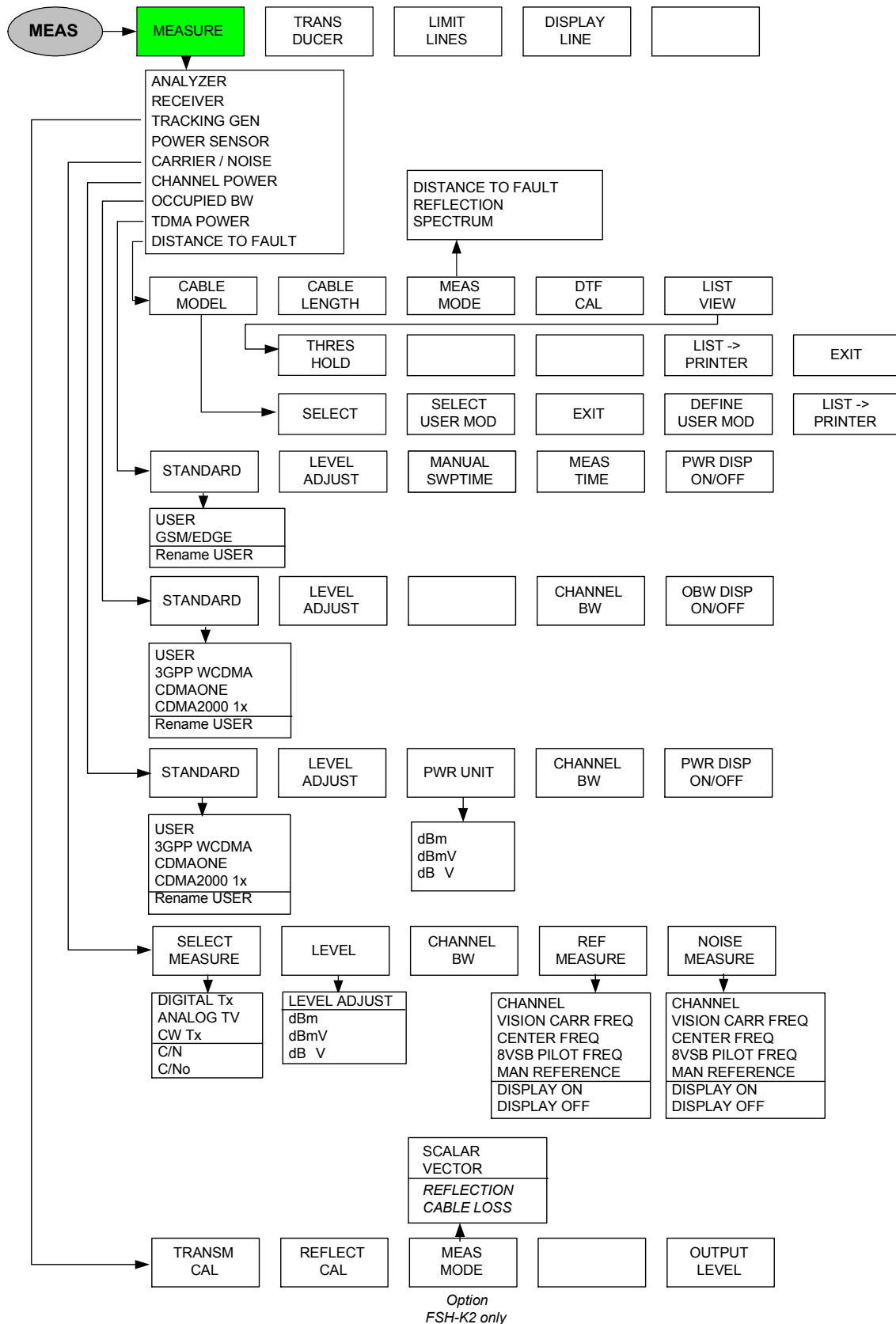

### Power sensor menus

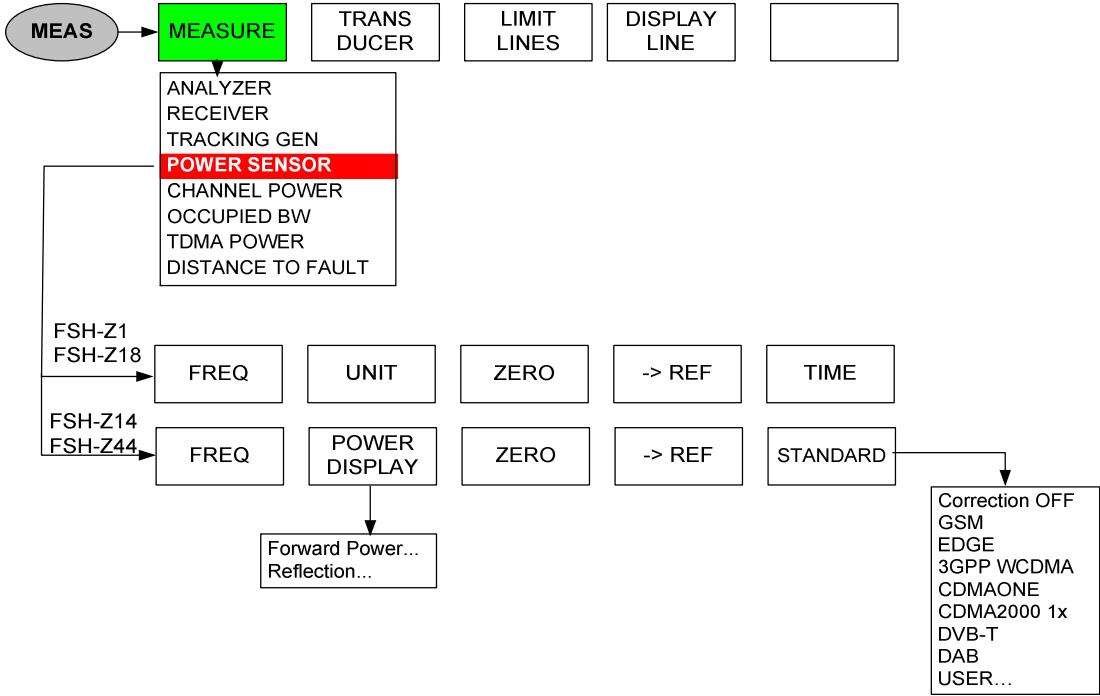

### Receiver mode (option R&S FSH-K3)

Main menu:

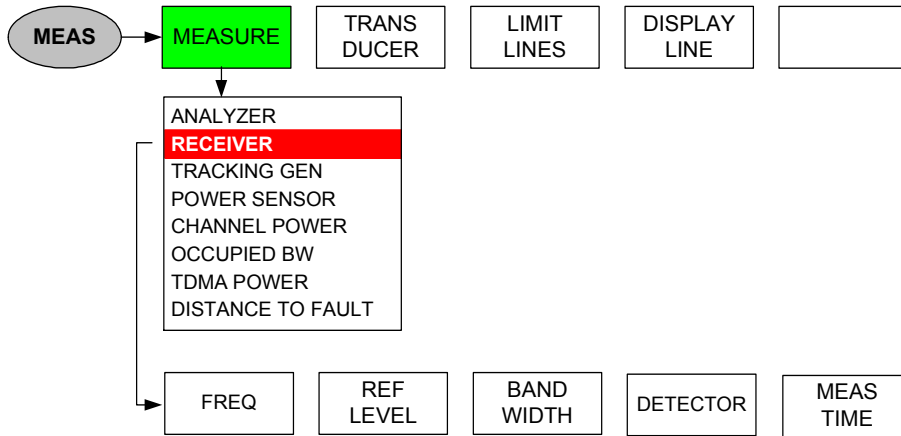

### FREQ key

Frequency entry:

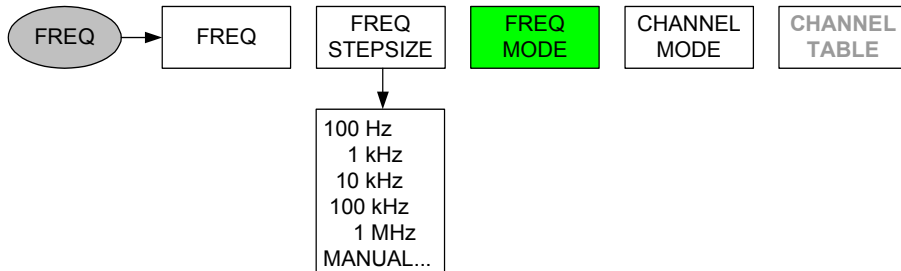

Channel entry:



**SPAN key**

**Frequency entry:**

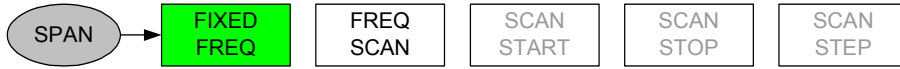

**Frequency scan:**

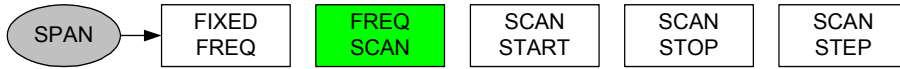

**Channel entry:**

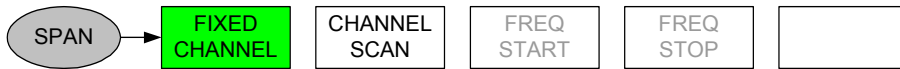

**Channel scan:**



**AMPT key**

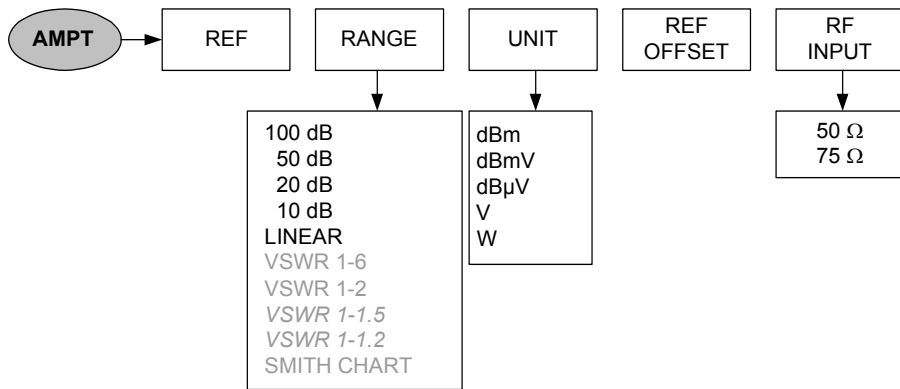

**Bandwidth entry**



Sweep key

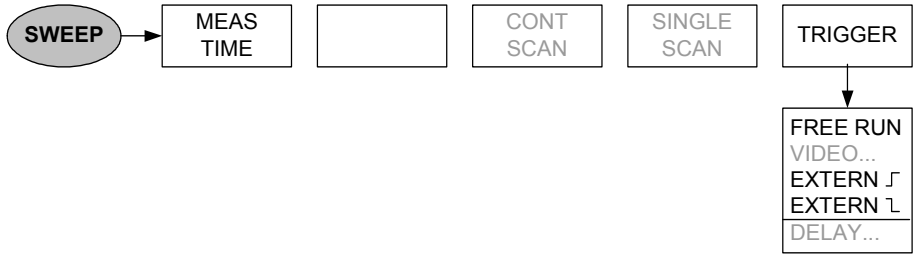

TRACE key

Measurement at a fixed frequency:



Scan mode:

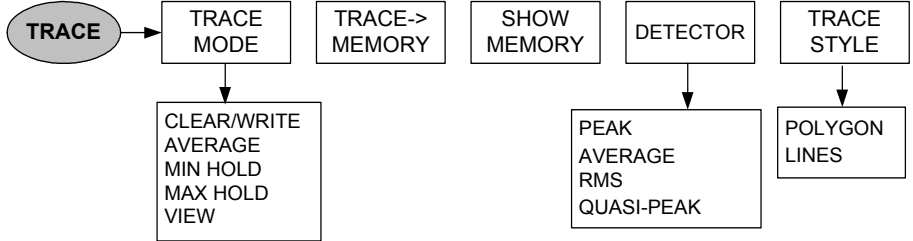

## 4 Instrument Functions

### Instrument Default Setup

When you press the PRESET key, the R&S FSH3-TV is set to its default setup or presets. It is best to select the PRESET when you are going to perform a new measurement task. The new settings can then be made on the basis of the more familiar default setup without the old settings affecting the measurement.

**Operating sequence:**

- Press the PRESET key (green key below and to the right of the rotary knob).

The R&S FSH3-TV is immediately set to the default setup.

### Status Display

The R&S FSH3-TV has a status display. On the screen, the status display provides an overview of all the measurement parameters that have just been set. This means that all the measurement settings can be checked easily at a glance. The status display can be output directly to a printer as measurement documentation. At a later date, every detail of a measurement can, therefore, be accurately reproduced.

**Operating sequence:**

- Press the STATUS key (above and to the right of the rotary knob).

The R&S FSH3-TV displays the current measurement parameter settings on the screen. To view all settings, the screen content can be scrolled through with the aid of the cursor keys or the rotary knob. An up or down arrow at the right screen edge indicates that additional information is available before or after the displayed window. The display can be used as a way of checking the settings. Settings can be changed by using the appropriate key and menu.

Printing out the status display:

- Press the STATUS -> PRINTER softkey.

The R&S FSH3-TV immediately prints out a screenshot to the connected printer. The softkey remains active for about ½ second (red highlighting).

Exiting the status display:

- Press the EXIT softkey or the STATUS key.

The R&S FSH3-TV returns to the original setting.

01/12/2002	INSTRUMENT STATUS	10:21:38
Measurement	: GSM / EDGE	
Center Frequency	: 920.2 MHz	
Frequency Offset	: 0 Hz	
Measurement Time	: 470 µs	
Reference Level	: 143 dBµV/m	
Reference Offset	: 0.0 dB	
RF Attenuator Setting	: 30 dB	
RF Input Reference	: 50 Ω	
Resolution Bandwidth	: 300 kHz	
Video Bandwidth	: 1 MHz	
Sweeptime	: 1 ms	
Trace Mode	: Clear / Write	▼
:	: EXIT	: STATUS-> PRINTER
01/12/2002	INSTRUMENT STATUS	10:22:26
RF Input Reference	: 50 Ω	▲
Resolution Bandwidth	: 300 kHz	
Video Bandwidth	: 1 MHz	
Sweeptime	: 1 ms	
Trace Mode	: Clear / Write	
Detector	: Sample	
Trigger Mode	: Video Trigger	
Trigger Level	: 50 %	
Trigger Delay	: 0 s	
Transducer	: HL223	
Transducer (dB)	: - - -	
:	: EXIT	: STATUS-> PRINTER

# Spectrum Analyzer

## Screen Layout

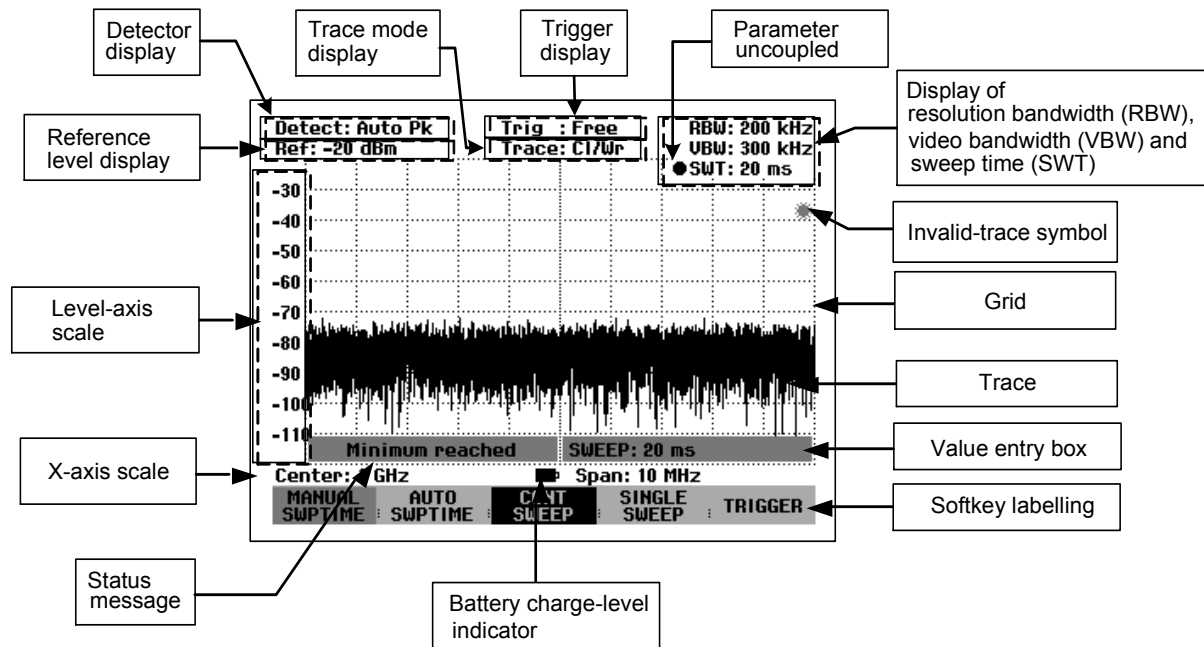

## Setting the Frequency

The R&S FSH3-TV's frequency is set with the **FREQ** key. The frequency can be specified in terms of the center frequency (center freq. = frequency at the center of the frequency axis in the measurement diagram) or the start and stop frequency for a particular span.

It is best to enter the center frequency when a signal is to be measured at a known frequency. When you are investigating signals, e.g. harmonics, that are within a particular frequency range, the best option is entering a start and stop frequency to define the span.

### Entering the center frequency

➤ Press the **FREQ** key.

The R&S FSH3-TV opens the frequency menu. Center frequency entry is always activated, so that the frequency settings can be made with the minimum number of keystrokes. The current center frequency is displayed in the value entry box. A new center frequency can be entered directly from the numeric keypad. You can also use the rotary knob or the cursor keys.

- Enter the frequency you want from the numeric keypad and terminate the frequency entry with the appropriate unit (GHz, MHz, kHz or Hz).

The frequency you have entered now becomes the new center frequency. The value entry box remains open for any further entries.

- As an alternative, you can change the center frequency with the rotary knob or the cursor keys and terminate the entry with the ENTER key.
- You can clear the value entry box from the screen by pressing the CANCEL key.

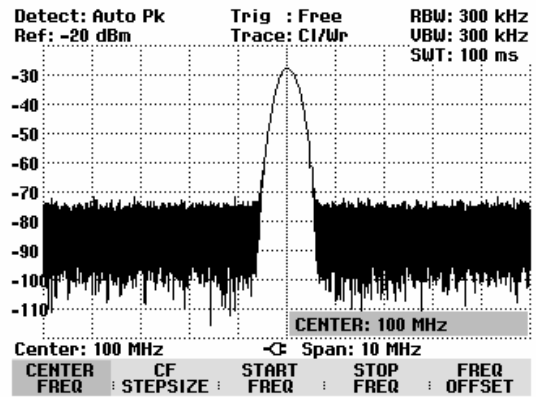

The smallest step for adjusting the center frequency with the rotary knob is a pixel, in other words, as the trace comprises about 300 pixels, each step is equal to about 1/300 of the span. When you use the cursor keys, a frequency step is equal to 10 % of the span (= 1 grid division). If you want to use a different stepsize, you can define it with the CF STEPSIZE function (CF = center frequency).

When you are adjusting the center frequency, you may obtain a value that is outside the R&S FSH3-TV's maximum span. If this happens, the R&S FSH3-TV automatically reduces the span. It also outputs the message "Span changed" to inform the user what has happened.



## Setting a frequency offset

For measurements on frequency converters such as satellite downconverters, it is often convenient to reference the results to the frequency prior to conversion. For this purpose, the R&S FSH3-TV offers a frequency offset, which arithmetically shifts the center frequency to higher or lower frequencies; thus, the R&S FSH3-TV displays the input frequency of the DUT.

Positive frequency offset is possible in the 10 Hz to 100 GHz range, in 10 Hz steps. The size of the negative frequency offset permitted depends on the start frequency setting; the start frequency, taking into account the frequency offset, is always  $\geq 0$  Hz.

- Press the **FREQ** key.
- Press the **FREQ OFFSET** softkey.

The R&S FSH3-TV opens the frequency offset entry field.

- Enter the required frequency offset and terminate with the corresponding unit.

The R&S FSH3-TV adds the frequency offset to the set center frequency. The center frequency display is marked by a red dot to indicate that a frequency offset has been set.

The frequency offset can be reversed if an offset of 0 Hz is entered.

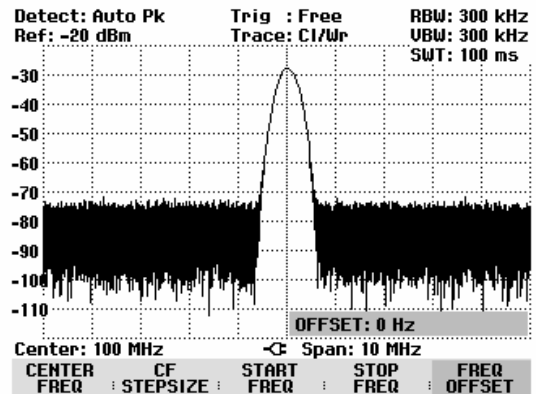

## Entering the center-frequency stepsize

- Press the **CF STEPSIZE** key.

A submenu above the softkey label opens. The box contains various stepsize setting options.

With 0.1 x SPAN (default setting), the stepsize is equal to 10 % of the span (= 1 division on the vertical scale).

With = CENTER, the stepsize is equal to center frequency. This setting is ideal for measurements on harmonics. On each frequency increment, the center frequency moves to the next harmonic.

With MANUAL... you can select any stepsize. This makes it easy to investigate spectra with frequencies at constant intervals.

- Make the selection you want with the rotary knob or the cursor keys and terminate with the **ENTER** key.

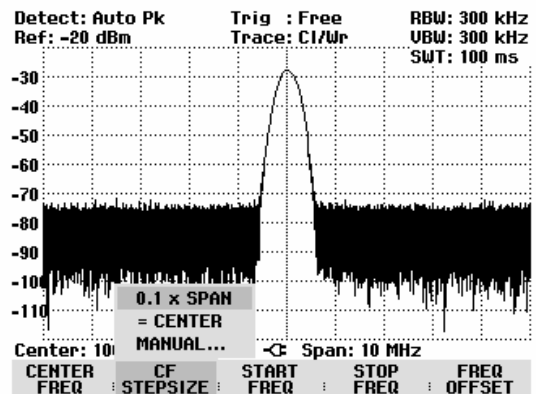

If you select "0.1 x SPAN" or "= CENTER", the R&S FSH3-TV makes the setting directly itself. If you select "MANUAL...", the value entry box opens and indicates the current stepsize.

- Using the rotary knob, the cursor keys or numeric entry, change the stepsize.
- When you have entered the stepsize you want, confirm by pressing the ENTER key or by pressing the CF STEPSIZE softkey.

### **Entering the start and stop frequency**

- Press the START FREQ softkey.

The value entry box for the start frequency opens. The box displays the current frequency.

- Enter a new start frequency with the number keys and terminate the entry with one of the unit keys or
- Adjust the start frequency with the rotary knob or the cursor keys and terminate the entry with the ENTER key.

The R&S FSH3-TV sets the new start frequency. The x axis labelling changes from CENTER and SPAN to START and STOP.

- Press the STOP FREQ softkey.

The R&S FSH3-TV opens the value entry box for the stop frequency. The box indicates the current frequency.

- Enter a new stop frequency using the number keys and terminate the entry with one of the unit keys, or
- Adjust the stop frequency with the rotary knob or the cursor keys and terminate the entry with the ENTER key.

The new stop frequency is now set on the R&S FSH3-TV.

If you enter a stop frequency which is greater than 3 GHz, or you reach the 3 GHz limit with the rotary knob or the cursor keys, the R&S FSH3-TV outputs the message "Maximum reached".

## Working with channel tables

Almost all transmission systems divide their assigned frequency ranges into channels, with a specific frequency assigned to each channel. The R&S FSH3-TV therefore allows users to define channel assignments using familiar terms to keep operation simple.

Channel tables are defined with the R&S FSH View software and loaded into the spectrum analyzer. The R&S FSH3-TV can store up to 15 different channel tables which can be activated from the front panel as required.

The R&S FSH View software operating manual describes how to generate channel tables.

Switching to channel entry:

- Press the **FREQ** key.
- Press the **CF STEPSIZE** softkey.
- Select **CHANNEL...** from the menu with the rotary knob or the cursor keys and confirm with the **ENTER** key.

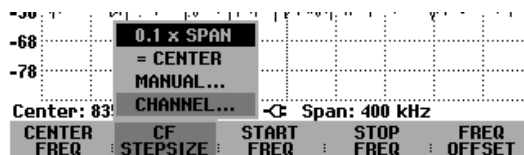

The R&S FSH3-TV opens the list of channel tables loaded via R&S FSH View.

- Select the desired channel table with the rotary knob or the cursor keys and switch it on with the **SELECT** softkey.

18/02/2004	BAND TABLE LIST	21:19:17
CATV	18/02/2004 21:19:08	
PCS UL	01/01/1995 01:00:00	
PCS DL	01/01/1995 01:00:00	
<b>GSM DL</b>	<b>01/01/1995 01:00:00</b>	
GSM UL	01/01/1995 01:00:00	



The channel number together with the name of the selected channel table (e.g. GSM UL Ch: 1) is now displayed instead of the center frequency. The **FREQUENCY** softkey is now called **CHANNEL**.

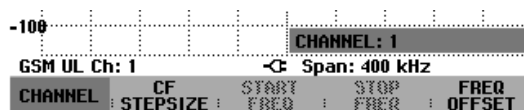

The R&S FSH3-TV center frequency is the frequency corresponding to the displayed channel number from the channel table. The R&S FSH3-TV accepts only channel numbers when entering the center frequency. Tuning the frequency with the rotary knob or the cursor keys is also done using channel numbers. If you exceed the definition of the channel table used, either "Minimum reached" is displayed on the screen when the lowest channel number is reached or "Maximum reached" is displayed when the highest channel number is reached. All other measurement parameters such as SPAN or RBW (resolution bandwidth) are user-selectable as with the entry of frequencies.

The entries for the start frequency (**START FREQ**) and the stop frequency (**STOP FREQ**) are inactive when defining channels.

Channel numbers are assigned to frequencies as follows:

- The first channel is assigned a channel number and a frequency.
- All subsequent channels have ascending numbers.
- The frequency spacing between channels is fixed. It can also be negative, i.e. the center frequency of the R&S FSH3-TV decreases with ascending channel number.
- In transmission systems containing gaps in the frequency range (as in the case of television, for example), a channel table can comprise multiple ranges.



## Setting the Amplitude Parameters

All R&S FSH3-TV settings referred to the level display are made with the AMPT key.

The reference level (REF) is the level represented by the uppermost grid line in the measurement diagram. The input signal gain up to the display stage is set with the reference level. If the reference level is low, the gain is high, which means that even weak signals are clearly displayed. If the input signals are strong, a high reference level must be set to prevent the analyzer signal path from being overdriven and to keep the signal display within the display range. When displaying the spectrum of a composite signal, the reference level should be at least high enough to ensure that all the signals are within the measurement diagram.

The RF attenuation setting at the input of the R&S FSH3-TV is directly coupled to the reference level. If the reference level is high, RF attenuation is switched on in steps of 10 dB according to the following table so that the input mixer always remains in the linear range.

The R&S FSH3-TV has two different modes for the attenuation setting. The modes are selected using the SETUP key and the GENERAL softkey (see chapter 1). In Low Distortion mode, the R&S FSH3-TV sets the RF attenuation 10 dB higher according to the above table, making the stress of the input mixer 10 dB less at the specified reference level. If the spectrum is densely occupied with signals, as occurs in a television cable network, the input mixer reduces the R&S FSH3-TV's inherent spurious products. However, the inherent noise display of the R&S FSH3-TV increases due to the increased attenuation before the input mixer.

If the preamplifier is switched on, it is also coupled to the reference level setting.

Ref Level	Preamplifier OFF		Preamplifier ON		
	RF attenuation		RF attenuation		Preamplifier
	Low noise	Low distortion	Low noise	Low distortion	
≤-25 dBm	0 dB	0 dB	0 dB	0 dB	On
-24 dBm to -20 dBm	0 dB	0 dB	10 dB	10 dB	On
-19 dBm to -15 dBm	0 dB	10 dB	10 dB	10 dB	On
-14 dBm to -10 dBm	0 dB	10 dB	0 dB	10 dB	Off
-9 dBm to 0 dBm	10 dB	20 dB	10 dB	20 dB	Off
1 dBm to 10 dBm	20 dB	30 dB	20 dB	30 dB	Off
11 dBm to 20 dBm	30 dB	30 dB	30 dB	30 dB	Off

The status of the RF attenuation and the preamplifier can be queried in the Status menu (press the STATUS key).

The reference level is in dBm for the default setting. However, the units dBmV, dBμV, Watt and Volt can also be selected. Unit selection is of most relevance to the marker level display as the marker level is displayed in the unit of the reference level.

A reference offset (REF OFFSET) can be defined for the reference level. The reference offset is a way of increasing the reference level by a certain amount. This is useful if, for example, an attenuator or amplifier has been inserted before the RF input. The R&S FSH3-TV automatically takes the loss or gain into account when the level is displayed and no manual calculations are necessary. A loss introduced at the RF input must be entered as a positive number and a gain as a negative number.

The measurement range (RANGE) determines the resolution along the level axis in the measurement diagram. When the PRESET or default setting has been selected, the level axis is scaled in dB. The measurement range is 100 dB or 10 dB per division (10 dB/DIV). The R&S FSH3-TV also provides the level ranges 50 dB (5 dB/DIV), 20 dB (2 dB/DIV), 10 dB (1 dB/DIV) and 1 dB (0.1 dB/DIV) which enhance resolution along the level axis. However, increasing resolution does not increase the accuracy of, for example, the marker level readout, but only makes it easier to read values off the trace. You can also select a linear level scale with LIN 0-100 %. The level is expressed as a percentage (0 % to 100 %) of the reference level. This mode is useful if you want to display, for example, a carrier being amplitude modulated in the time domain (SPAN = 0 Hz).

The R&S FSH3-TV can also handle measurements on 75  $\Omega$  systems. The R&S FSH does not select a 75  $\Omega$  RF input per se, but instead only the 50/75  $\Omega$  Matching Pad R&S RAZ connected at the RF input (see recommended accessories). The R&S FSH3-TV automatically considers the conversion factor when a value of 75  $\Omega$  is set. Other matching pads such as the matching pads R&S FSH-Z38 or R&S RAM can be taken into account by using a transducer factor.

## Setting the reference level

- Press the AMPT key.

The reference level entry is activated immediately. The REF LEVEL softkey label is highlighted in red.

- Enter a reference level with the number keys and either terminate the entry with one of the unit keys (-dBm or dBm for relative measurements or (), m,  $\mu$ , n for absolute measurements) or press the ENTER key, or
- Adjust the reference level with the rotary knob or the cursor keys.

Any changes you make to the reference level with the rotary knob or the cursor keys are immediate. The trace moves as changes to the reference level are made.

- When the reference level you want has been set, you can remove the value entry box from the screen by pressing the CANCEL key.

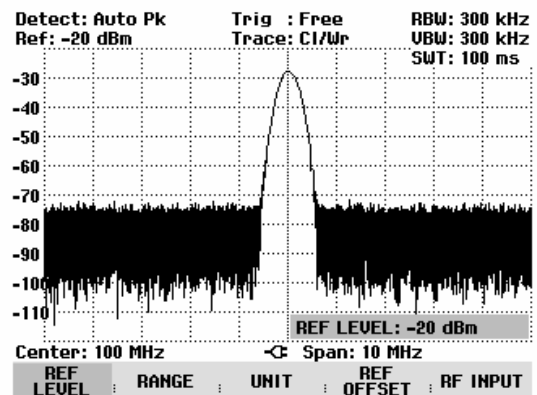

## Entering the display range

- Press the AMPT key.
- Press the RANGE softkey.

A submenu opens. The various options for scaling the level axis are displayed.

- Using the rotary knob or the cursor keys, select the scaling option you want and confirm your selection by pressing the ENTER key.

The scaling option you have chosen is immediately set on the R&S FSH3-TV.

The menu items VSWR 1-6 and VSWR 1-2 are valid scaling options only if the R&S FSH3-TV is configured for reflection measurements. If the R&S FSH-K2 option is installed, the ranges VSWR 1-1.5 and VSWR 1-1.1 are available in addition.

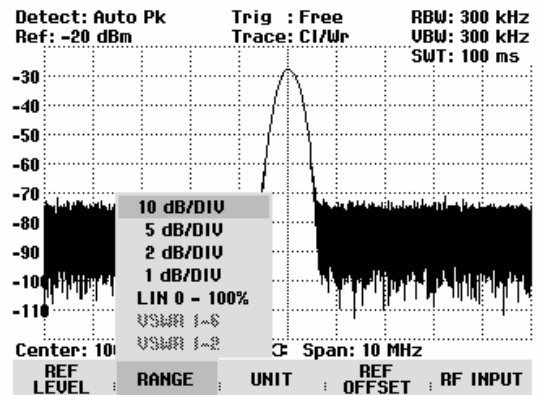

## Entering the display unit

- Press the AMPT key.
- Press the UNIT softkey.

A submenu opens. The various unit options for the reference level are displayed.

- Using the rotary knob or the cursor keys, select the unit you want and confirm your selection by pressing the ENTER key.

The reference level unit is immediately set on the R&S FSH3-TV.

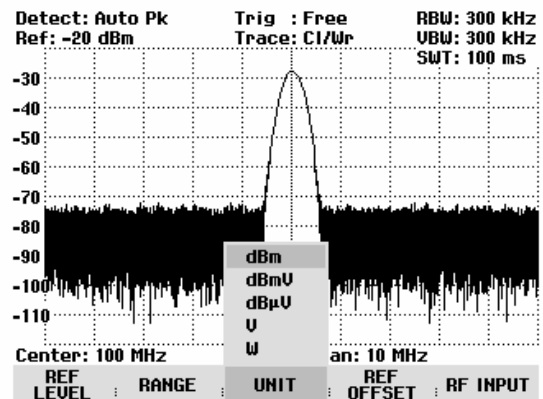

### Entering the reference offset

- Press the AMPT key.
- Press the REF OFFSET softkey.
- Using the number keys, enter a reference offset and terminate the entry with one of the unit keys or the ENTER key, or
- Change the reference level using the rotary knob or the cursor keys.

The reference offset unit is always dB – no matter what unit is used for the reference level.

To indicate that a non-zero reference offset has been set, a red circle is placed before the reference level readout.

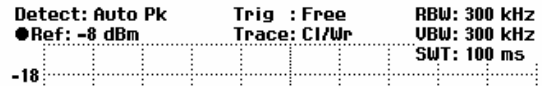

### Entering the input impedance

- Press the AMPT key.
- Press the RF INPUT softkey.

A submenu opens. The two input impedance options “50 Ω” and “75 Ω” are displayed.

- Select the input impedance you want using the rotary knob or the cursor keys and confirm your selection by pressing the ENTER key.

*Note: If you have selected 75 Ω, and do not connect the Matching Pad R&S RAZ to the RF input, incorrect level readings will be obtained.*

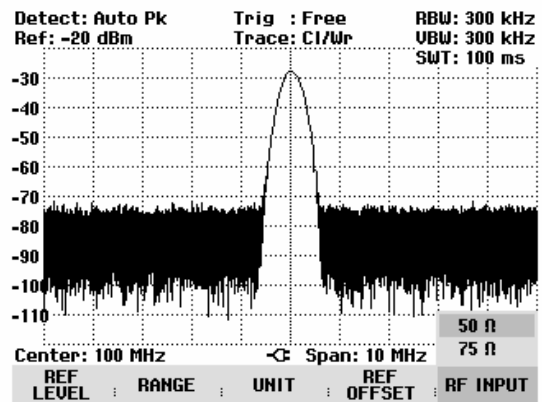



## Setting the Bandwidths

A key feature of a spectrum analyzer is that it can display the frequency spectrum of a signal. The resolution bandwidth determines how well a spectrum analyzer can separate adjacent frequencies. Spectrum analyzers usually also have switchable video bandwidths. The video bandwidth is determined by the cutoff frequency of the lowpass used to filter the video voltage before it is displayed. The video voltage is the spectrum analyzer term for the voltage produced when the IF signal which has been band-limited by the resolution filter is envelope detected. The video voltage is smoothed by video filtering to, say, reduce noise on the trace. Unlike the resolution bandwidth, the video bandwidth has no effect on the resolving power of the spectrum analyzer.

### Resolution bandwidth

The resolution bandwidth (RES BW) of a spectrum analyzer determines the frequency resolution of spectrum measurements. A sine signal is displayed on the screen "through" the passband of the selected resolution filter. Therefore, a suitably small resolution bandwidth is required if two or more signals whose frequencies are close together are to be displayed separately. The frequency difference between two sinusoidal carriers, for example, cannot be less than the selected resolution bandwidth if the carriers are to be resolved. Which resolution bandwidth is selected also has an effect on the noise displayed by the spectrum analyzer. If the bandwidth is small, the noise displayed drops. If the bandwidth is reduced or increased by a factor of 3, the noise displayed drops or goes up by 5 dB. If the bandwidth is changed by a factor of 10, the displayed noise changes by 10 dB. Which resolution bandwidth is selected also has an effect on the sweep speed. If the true spectrum is to be displayed, the bandfilters that determine the resolution bandwidth must settle at all frequencies of interest. Narrow bandfilters take longer to settle than wide filters. This is why a longer sweep time must be selected for narrow resolution bandwidths. If the bandwidth is reduced by a factor of 3 (e.g. from 10 kHz to 3 kHz), the sweep time must be increased by a factor of 9. If the reduction factor is 10 (e.g. from 10 kHz to 1 kHz) the sweep time must be increased by a factor of 100.

The R&S FSH3-TV has resolution bandwidths from 100 Hz to 1 MHz in a 1, 3, 10 sequence. When the default setting is selected, they are coupled to the span, i.e. if the span is reduced, a smaller resolution bandwidth is automatically set. This means that in many cases the resolution bandwidth does not have to be set separately – a higher frequency resolution is automatically set when the span is reduced.

The R&S FSH3-TV offers a 200 kHz resolution bandwidth in addition. This bandwidth has to be selected manually, i.e. it will not be activated automatically in the AUTO RES BW mode (resolution bandwidth coupled to span).

**Operating sequence:**

- Press the BW key.

The menu for setting the bandwidth opens. If the default setting is activated, the softkey label for automatically setting the bandwidth is highlighted in green.

- Press the MANUAL RES BW softkey

The softkey label is highlighted in red and the value entry box for the resolution bandwidth (RBW) indicates the current bandwidth. To indicate that the resolution bandwidth is not coupled to the span, a small red circle is placed before the resolution bandwidth display in the top right-hand corner of the screen.

- Enter the resolution bandwidth you want using the number keys and terminate the entry with the appropriate unit (MHz, kHz or Hz), or
- Change the resolution bandwidth to the value you want using the rotary knob or the cursor keys.

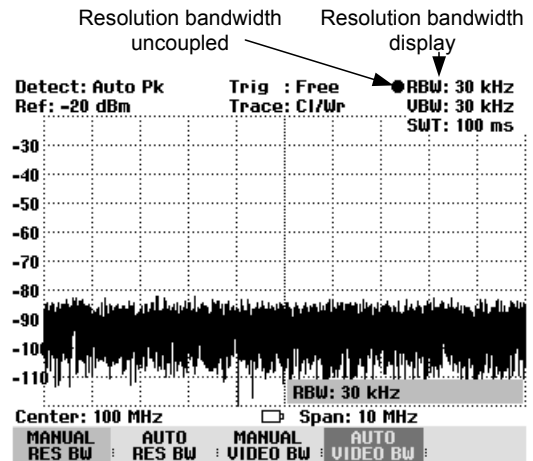

*Note: The 200 kHz resolution bandwidth has to be entered by means of the number keys. When using the rotary knob or the cursor keys, the 200 kHz bandwidth will be skipped.*

The box for entering the resolution bandwidth can be closed by pressing the CANCEL key.

- Press the AUTO RES BW softkey.

The resolution bandwidth is coupled to the span that has been set. The AUTO RES BW softkey label is highlighted in green to show that the coupled mode has been selected. The red circle in front of the RBW readout disappears.

## Video bandwidth

The video bandwidth smoothes the trace by reducing noise. When the filtered IF signal is envelope-detected, an IF sine signal becomes a DC voltage in the video signal. If the sine signal is amplitude-modulated, a signal whose frequency is the same as the AM frequency is produced in the video signal apart from the DC voltage from the carrier. The Fig. below shows an RF signal modulated with a sine signal and the corresponding video signal in the time domain.

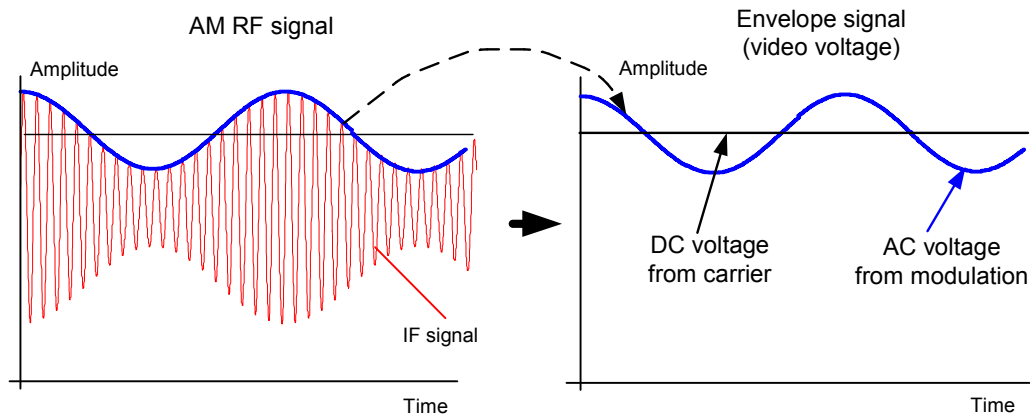

The envelope signal contains a DC component corresponding to the carrier level and an AC component whose frequency is the same as the AM frequency. If the bandwidth of the video filter is less than the frequency of the AC component, the latter will be suppressed depending on its maximum frequency. If the AM component is to be displayed faithfully, the cutoff frequency must be greater than the modulation frequency.

If there is noise on the sine signal, the modulation signal can be thought of as noise. If the video bandwidth is reduced, the high-frequency noise components above the cutoff frequency of the video filter will be rejected. The smaller the video bandwidth, the smaller the noise amplitude at the video filter output.

Therefore, the following rules of thumb can be applied to setting the video bandwidth:

- If you are performing measurements on modulated signals, the video bandwidth must be sufficiently large so that wanted modulation components are not rejected ( $\geq$  RBW).
- If signals are to be kept free of noise, the smallest video bandwidth possible should be selected ( $\leq 0.1 \times$  RBW).
- If measurements are being performed on pulsed signals, the video bandwidth should be at least three times greater than the resolution bandwidth so that the pulse edges are not distorted.

Like the resolution bandwidth, the video bandwidth has an effect on sweep speed. The spectrum analyzer must pause before each measurement to allow the video filter to settle.

The R&S FSH3-TV has video bandwidths from 10 Hz to 3 MHz in a 1, 3, 10 sequence. When the default settings are selected, they are coupled to the resolution bandwidth. The video bandwidth equals the resolution bandwidth. When the resolution bandwidth is changed, the R&S FSH3-TV automatically sets the appropriate video bandwidth. This means that, in many cases, the video bandwidth does not need to be set separately. When the resolution bandwidth is changed, the video bandwidth is changed automatically.

**Operating sequence:**

- Press the BW key.

The menu for setting bandwidths opens. When the default setting has been selected, the softkey label for setting the bandwidth automatically is highlighted in green.

- Press the MANUAL VIDEO BW softkey.

The softkey label is highlighted in red and the video bandwidth value entry box (VBW) indicates the current bandwidth. To indicate that the video bandwidth is not coupled to the resolution bandwidth (RBW), a small, red circle is placed before the video bandwidth readout in the top right-hand corner of the screen.

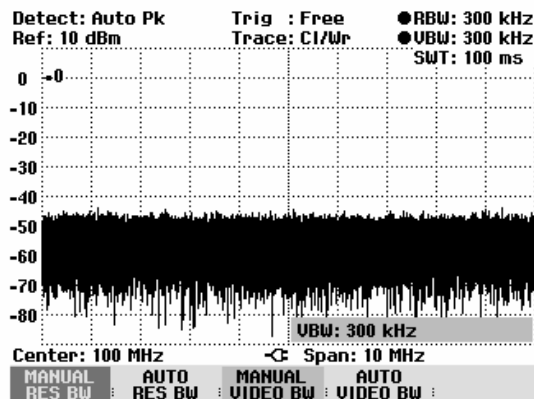

- Enter the video bandwidth you want with the number keys and terminate the entry with the appropriate unit (MHz, kHz or Hz), or
- Change the video bandwidth to the value you want using the rotary knob or the cursor keys.

The video bandwidth value entry box is closed by pressing the ENTER key.

- Press the AUTO VIDEO BW softkey.

The video bandwidth is coupled to the resolution bandwidth that has been set. The AUTO VIDEO BW softkey label is highlighted in green to indicate coupling and the red circle marking the VBW readout disappears.

## Setting the Sweep

If the span is  $> 0$ , the sweep time is the time the spectrum analyzer takes to traverse the displayed span to measure the spectrum. Certain boundary conditions must be met if a spurious spectrum is not to be displayed.

One boundary condition is the resolution bandwidth. If the resolution filter is to settle, the dwell time within the filter bandwidth must have the right value. If the sweep time is too short, the resolution filter does not settle and the displayed level is too low (see also "Setting the Bandwidth").

The second boundary condition is the selected span. If the span is increased, the sweep time must be increased proportionally.

The R&S FSH3-TV provides automatic sweep time coupling to help users set the sweep time by coupling it to the resolution bandwidth and span that have been set. When automatic coupling (AUTO SWEEP TIME) is selected, it always sets the shortest sweep time possible to ensure that sine signals in the spectrum are displayed correctly. When you quit the auto sweep time mode (MANUAL SWPTIME is activated instead), a small, red circle is placed in front of the SWT readout to indicate that the uncoupled mode has been selected. If the sweep time is so short that level errors occur, the R&S FSH3-TV informs the user by displaying a red circle on the right-hand side of the measurement diagram.

The R&S FSH3-TV requires a minimum sweep time of 20 ms per 600 MHz of span. If a larger span is set, the R&S FSH3-TV automatically adapts the minimum sweep time in the coupled mode. For the maximum span of 3 GHz a minimum sweep time of 100 ms is required.

If the span = 0 Hz, the R&S FSH3-TV displays video voltage versus time instead of a spectrum. The x axis of the measurement diagram becomes the time axis, starting at 0 s and ending at the sweep time you have selected.

The minimum sweep time when the span = 0 Hz is 1 ms, the maximum 1000 s.

## Sweep time

- Press the SWEEP key.

The softkey menu for entering sweep parameters opens. If the default settings have been selected, automatic coupling (AUTO SWPTIME) is set. In this mode, the sweep time is coupled to the resolution bandwidth, the video bandwidth and the span.

- To enter the sweep time, press the MANUAL SWPTIME softkey.

The SWEEP value entry box opens and indicates the current sweep time setting.

- Enter a new sweep time with the number keys and terminate the entry with one of the unit keys, or
- Change the sweep time with the rotary knob or the cursor keys.

Whenever a change is made, the sweep time is immediately set to its new value. The value entry box is closed by pressing the ENTER key. The sweep time that has been set is displayed in the top right-hand corner of the screen in the SWT readout box.

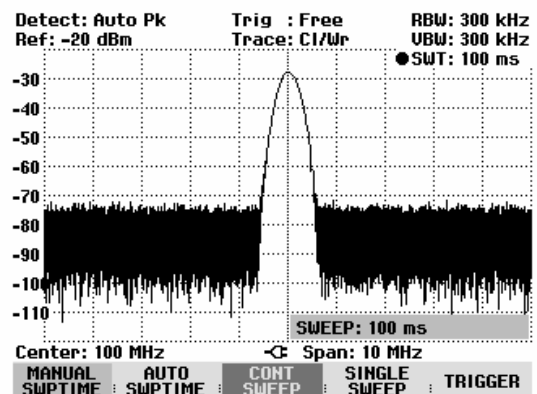

## Sweep mode

When the default settings are activated, the R&S FSH3-TV is in the continuous sweep mode, i.e. when one sweep of the span has been completed, the sweep is automatically repeated from the start of the span. The trace is refreshed after each sweep.

The continuous mode may not be needed for some applications, e.g. when a single event is to be recorded on certain trigger conditions being met. The R&S FSH3-TV, therefore, has a SINGLE SWEEP mode. When the single sweep mode is selected, the R&S FSH3-TV sweeps once over the span or displays the time-domain video signal once in the zero-span mode. The measurement will only be repeated if you press the SINGLE SWEEP softkey.

➤ Press the SWEEP key.

If the default setting is selected, the CONT SWEEP softkey label is highlighted in green to indicate that the continuous sweep mode has been set.

➤ Press the SINGLE SWEEP softkey.

The SINGLE SWEEP softkey label is highlighted in green. The R&S FSH3-TV performs a single sweep and waits for further entries.

➤ Press the CONT SWEEP softkey.

The R&S FSH3-TV now sweeps continuously again.

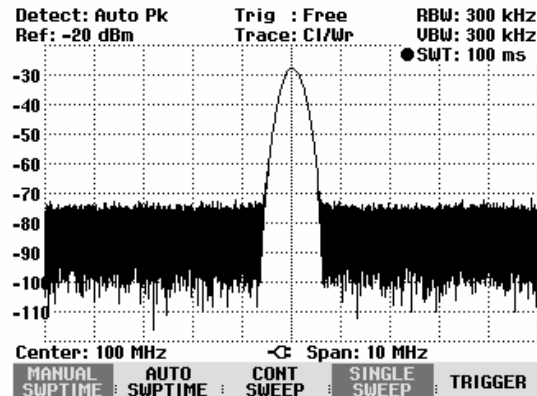

## Trigger

To respond to events, the R&S FSH3-TV has a variety of trigger functions. The trigger can either be external or generated internally.

- FREE RUN      A new sweep starts on completion of the previous sweep. This is the default setting for the R&S FSH3-TV.
- VIDEO      A sweep starts when the video voltage exceeds a settable value. Video triggering is only available when span = 0 Hz. When a frequency spectrum is being displayed, (span  $\geq$  10 kHz), there is no guarantee that a signal to generate a video voltage is present at the start frequency. Under these circumstances, the R&S FSH3-TV would never perform a sweep.
- EXTERN  $\lceil$  and EXTERN  $\rfloor$       The sweep is started on the rising edge ( $\lceil$ ) or on the falling edge ( $\rfloor$ ) of an external trigger signal. The external trigger signal is fed in via the BNC connector EXT TRIGGER. The switching threshold is 1.4 V, i.e. a TTL signal level.

When a video trigger or an external trigger is selected, the start of measurement can be delayed with respect to the trigger event by entering a delay (DELAY). In this way, time differences between the trigger event and the measurement can be allowed for.

The current trigger setting is displayed centrally at the top of the screen (e.g. Trig: Free).

**Operating sequence:**

- Press the SWEEP key.
- Press the TRIGGER softkey.

The submenu for setting the trigger opens. If the default setting is selected, FREE RUN is highlighted in red. If span = 0 Hz, any setting can be selected; otherwise the settings VIDEO... and DELAY... are in darker labelling to show that they are not available.

- Select the setting you want with the cursor keys or the rotary knob and terminate the entry with the ENTER key or with the TRIGGER softkey.

The "Trig:" box at the center of the top of the screen indicates the setting that has been selected.

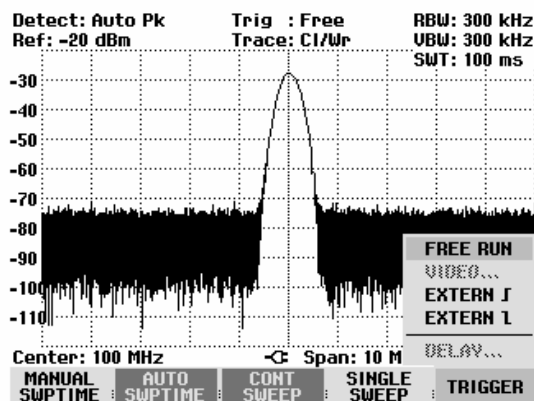

If the VIDEO... trigger setting has been selected, the trigger level and any trigger delay (DELAY...) must be entered. The trigger level is expressed as a percentage (%) of the reference level. 100 % means that the trigger level equals the reference level, 50 % that the trigger level is in the middle of the y axis on the measurement diagram (default setting). The position of the video trigger on the level axis is shown by a ">".

- Change the video-trigger threshold with the cursor keys or the rotary knob (0 to 100 %).

The trigger threshold is set immediately after entry.

- Terminate the trigger threshold entry with the ENTER key or the TRIGGER softkey.

The value entry box is then closed.

- If a trigger delay is required, press the TRIGGER softkey.
- Using the cursor keys or the rotary knob, select DELAY... and confirm with the ENTER key or the DELAY... softkey.

The delay value entry box is then opened.

- Using the number keys, the cursor keys or the rotary knob, enter the delay and terminate the entry with the ENTER key or the TRIGGER softkey.

The trigger delay range is 0  $\mu$ s to 100 s. The resolution is 10  $\mu$ s up to 1 ms and 100  $\mu$ s from 1 ms to 10 ms.

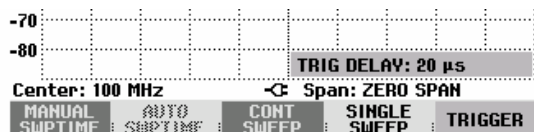
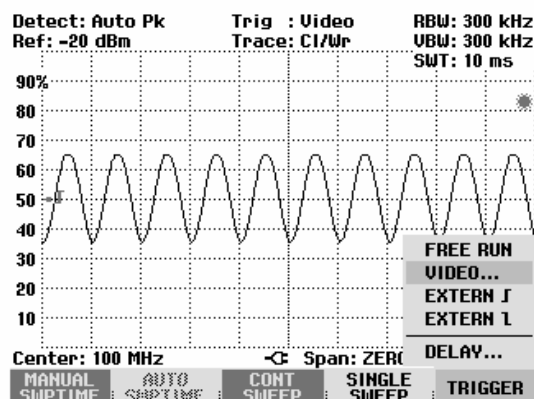

The trigger delay resolution depends on the delay selected. The table below lists the values:

<b>Trigger delay (DELAY)</b>	<b>Resolution</b>
0 to 1 ms	10 $\mu$ s
1 ms to 10 ms	100 $\mu$ s
10 ms to 100 ms	1 ms
100 ms to 1 s	10 ms
1 s to 10 s	100 ms
10 s to 100 s	1 s



## Trace Settings

The R&S FSH3-TV provides one measurement trace and a reference trace in memory.

### Trace mode

A variety of display modes can be selected for the trace:

- CLEAR/WRITE                      The R&S FSH3-TV clears the old trace during a new sweep. This is the default setting.
- AVERAGE                          The R&S FSH3-TV takes the level average over consecutive traces. In the default setting, averaging is on a pixel-by-pixel basis, sliding over the ten previous traces. Alternatively, you can set the number of averagings between 2 and 999. This reduces the effects of noise, for example, but has no effect on sine signals. The average mode, therefore, makes it easy to display sine signals in the vicinity of noise.
- MAX HOLD                          The trace indicates the maximum value that has been measured up to that point in time. The Max Hold mode is only cancelled if another setting is selected and the trace pixels from the new setting cannot be compared with the trace pixels from the previous setting – for example if the span is changed. Intermittent signals in the spectrum or the maximum of fluctuating signals are easy to find with MAX HOLD.
- MIN HOLD                          The trace indicates the minimum value that has been measured up to that point in time. The Min Hold mode is only cancelled if another setting is selected and the trace pixels from the new setting cannot be compared with the trace pixels from the previous setting – for example if the span or the center frequency is changed. With MIN HOLD, sine signals within the noise can be highlighted or intermittent signals suppressed.
- VIEW                                The R&S FSH3-TV freezes the presently displayed trace. The measurement is aborted. This, for instance, allows subsequent evaluation of spectra with the aid of the marker.

**Operating sequence:**

- Press the TRACE key.
- Press the TRACE MODE softkey.

The submenu for setting the trace mode opens.

- Using the cursor keys or the rotary knob, select the trace mode you want and confirm with the ENTER key or the TRACE MODE softkey.

The "Trace:" display at the center of the top of the display shows the trace mode that has been selected.

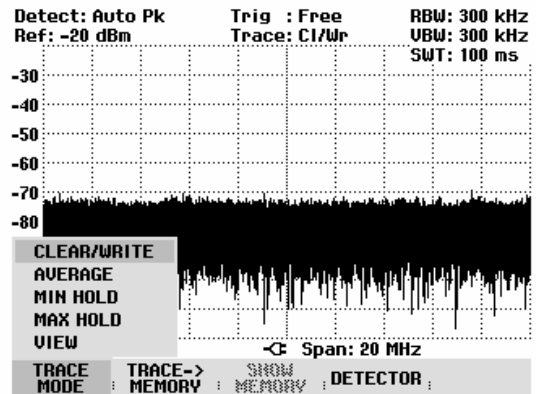

If TRACE MODE AVERAGE is selected, the AVG COUNT entry field opens, which displays the set number of averagings.

The following actions can be performed:

- Confirm the displayed number of averagings with the TRACE softkey or the ENTER key.
- Using the numeric keypad, enter a new figure between 2 and 999 for specifying the number of averagings and confirm your entry with the TRACE softkey or the ENTER key.
- Change the number of averagings by using the rotary knob and confirm your entry with the TRACE softkey or the ENTER key.

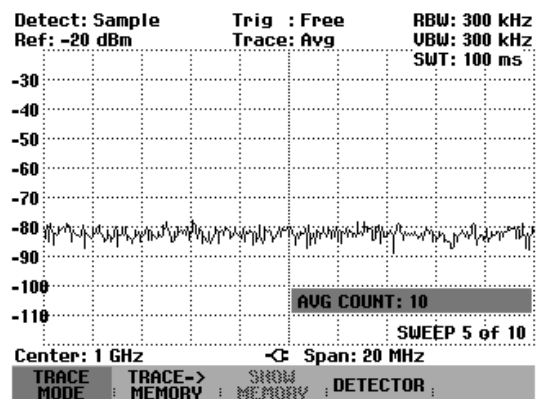

The R&S FSH3-TV averages the pixels of the trace across the set number of averagings.

If the sweep is continuous, the R&S FSH3-TV then performs a sliding averaging. In the SINGLE SWEEP mode, it performs exactly those sweeps defined with AVG COUNT and averages the traces. It then stops the sweep and displays the averaged trace.

In the trace mode VIEW, the settings used for measuring the trace are displayed. This ensures that the measurement conditions can be clearly specified in result documentation. In the status display (STATUS key) it is indicated in brackets that the view mode is currently selected, e.g. Trace Mode: Maximum Hold (View).

## Detector

The detector processes a spectrum analyzer's video voltage before it is displayed. The detector is pixel-oriented, i.e. it determines how the level at each pixel will be displayed. The R&S FSH3-TV always measures the whole spectrum. However, the trace only has 301 pixels in the x direction for displaying results. If a large span is selected, all the spectrum information must somehow be represented using only 301 points. Each pixel represents a frequency range equal to span/301. Four different detectors are available:

- **AUTO PEAK** When the Auto Peak detector is selected, the R&S FSH3-TV displays the maximum and minimum level at each pixel for the frequency range in question. This means that when Auto Peak detection is selected no signals are lost. If the signal level fluctuates, as is the case with noise, the width of the trace is a measure of signal fluctuation. Auto-peak detection is the default setting.
- **MAX PEAK** Unlike the Auto Peak detector, the Max Peak detector only finds the maximum value within the frequency range associated with one trace pixel. Its use is recommended for measurements on pulse-like signals or FM signals.
- **MIN PEAK** The Min Peak detector yields the minimum value of the spectrum within a pixel of the trace. Sine signals are displayed with correct level but noise-like signals are suppressed. The Min Peak detector can be used to highlight sine signals in the noise spectrum.
- **SAMPLE** The Sample detector does not "summarize" any aspect of the spectrum which is available in its complete form in the R&S FSH3-TV, but instead shows only one arbitrary measurement point within a pixel. The Sample detector should always be used for measurements with span = 0 Hz, as this is the only way of correctly representing the timing of the video signal. The Sample detector can also be used to measure noise power as noise usually has a uniform spectrum with a normal amplitude distribution. If the Sample detector is used for signal spectrum measurements with a span that is greater than (resolution bandwidth x 301), signals may be lost.
- **RMS** The RMS detector measures spectral power over a pixel. No matter what the signal shape, power measurements with the RMS detector always give the true power. RMS detection is recommended for power measurements on digitally modulated signals in particular. This is because the RMS detector is the only R&S FSH3-TV detector that can give stable, true power readings. Display stability can easily be obtained by increasing the sweep time, as the measurement time for the power/pixel increases the greater the sweep time. If you are making noise measurements, for example, the trace will be highly stable if a long sweep time is selected.

However, the bandwidth occupied by the signal to be measured should at least equal the frequency covered by a trace pixel or the selected resolution bandwidth (whichever is larger). Otherwise, the power shown by the R&S FSH3-TV is too low because there are spectral components within the frequency range covered by the pixel which do not come from the signal under measurement (e.g. noise).

To obtain the true power, the video bandwidth (VBW) too should be selected to be greater than the resolution bandwidth (RBW). Otherwise, an averaging effect caused by video bandlimiting comes into play before the RMS value is calculated.

Both automatic operation and manual operation are available for setting the detector. In automatic operation, the R&S FSH3-TV selects the detector that is suitable for the trace mode that is set. In manual operation, the selected detector is always maintained regardless of the trace mode.

Setting of the detector in automatic operation:

Trace mode	Detector
Clear/Write	Auto Peak
Average	Sample
Max Hold	Max Peak
Min Hold	Min Peak

**Operating sequence:**

- Press the TRACE key.
- Press the DETECTOR softkey.

The submenu for selecting the detector opens.

If automatic operation has been selected, the AUTO COUPLED menu item is highlighted in green and the R&S FSH3-TV displays the detector that is set to match the trace mode that is set.

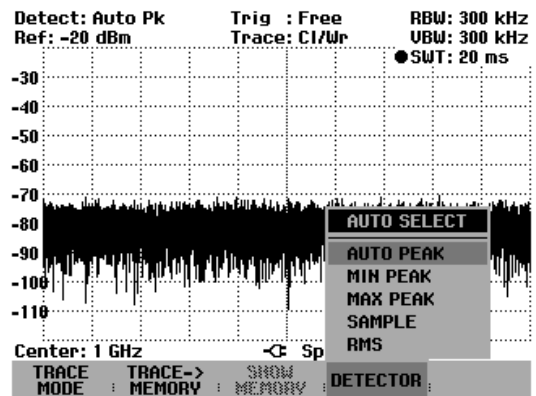

**To switch automatic operation on or off:**

- Using the cursor keys or rotary knob, select AUTO COUPLED from the menu.
- Using the ENTER key or the DETECTOR softkey, switch automatic operation on or off.

When automatic operation is switched on, the R&S FSH3-TV also sets the detector that matches the trace mode that is set.

**To set the detector manually:**

- Using the cursor keys or the rotary knob, select the detector you want and confirm by pressing the ENTER key or the DETECTOR softkey.

The R&S FSH3-TV indicates the detector that has been selected in the top left-hand corner of the screen (Detect: Auto Pk in Fig. above). If AUTO COUPLED is switched on and a detector that does not accommodate automatic operation is set, the R&S FSH3-TV will switch automatic operation off.

## Trace memory

The R&S FSH3-TV can transfer a trace to the trace memory and also display the current trace and the trace in the trace memory for comparison. The saved trace is always displayed in white to distinguish it from the current trace.

### Operating sequence:

- Press the TRACE key.
- Press the TRACE -> MEMORY softkey.

The R&S FSH3-TV transfers the currently displayed trace to the trace memory.

- Press the SHOW MEMORY softkey.

The R&S FSH3-TV displays the saved trace in white. The SHOW MEMORY softkey label is highlighted in green to indicate that the trace in the trace memory is being displayed.

- To remove the saved trace from the screen, press the SHOW MEMORY softkey again.

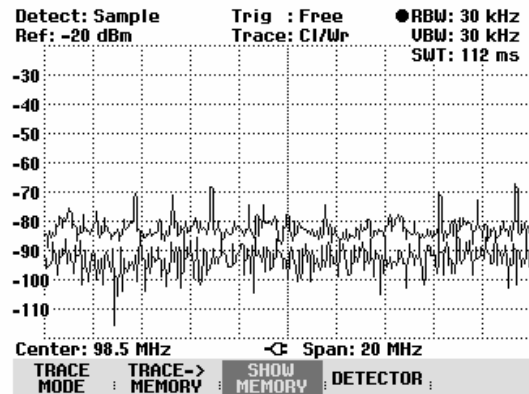

**Note:** *The memory trace is bit-mapped into the picture memory. Therefore, when the memory trace is recalled, it will not be adapted to any modifications of the reference level or span that may have been made in the meantime.*

*When a stored data set is called, the R&S FSH3-TV stores the associated trace in the trace memory. The stored trace can be displayed with SHOW MEMORY.*

## Using the Markers

The R&S FSH3-TV has a marker and a delta marker to make it easier to read off trace values. The markers cannot leave the trace and indicate the frequency and level of the point they are positioned on. The frequency indicated by a marker is shown by a vertical line which extends from the top to the bottom of the measurement diagram. The numeric frequency and level readouts are displayed in the top left-hand corner of the screen. The unit is the same as the unit of the reference level.

The position of the delta marker is indicated by a dashed line to distinguish it from the other marker. The delta marker level is always a level relative to the main marker level and so the delta marker level unit is always dB. The delta marker frequency is always relative to the main marker – in other words, the delta marker frequency is the frequency difference between the frequency at the point marked by the main marker and the frequency at the point marked by the delta marker.

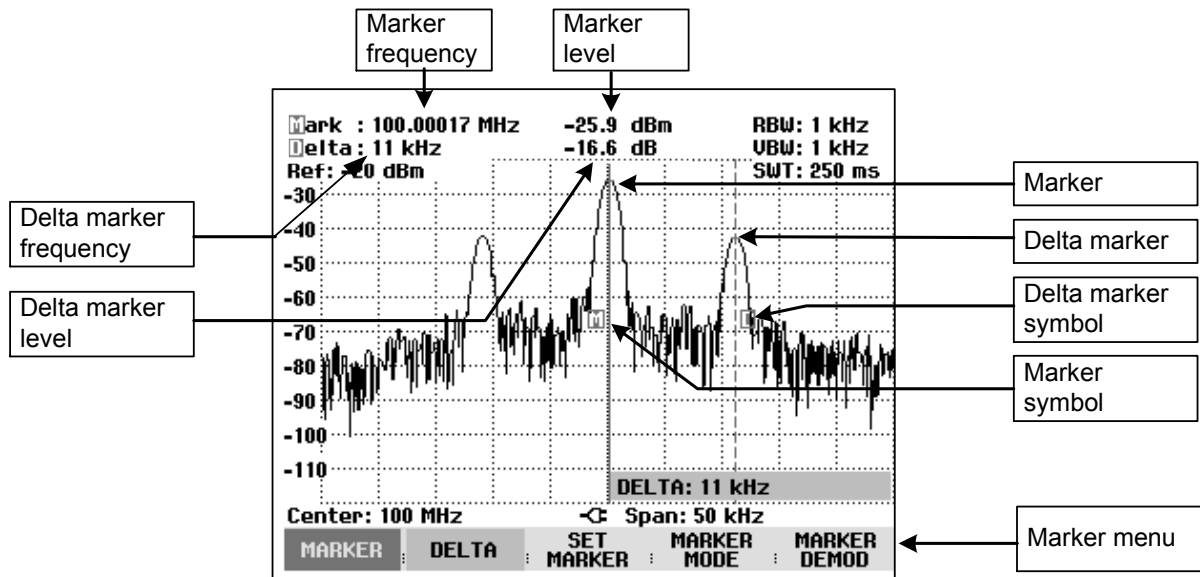

### Controlling the marker:

- Press the MARKER key.

The marker menu opens. If, as yet, no marker has been activated, the main marker (MARKER) is turned on automatically and placed on the maximum level in the spectrum. The frequency and level at the point indicated by the marker are displayed at the top of the screen in the selected unit (= reference level unit). The value entry box for the marker frequency opens.

The following actions can now be performed:

- Change the marker position using the rotary knob or the cursor keys.
- Enter a marker position with the number keys and terminate the entry with one of the unit keys.
- Confirm the marker position by pressing the ENTER key or the MARKER softkey.

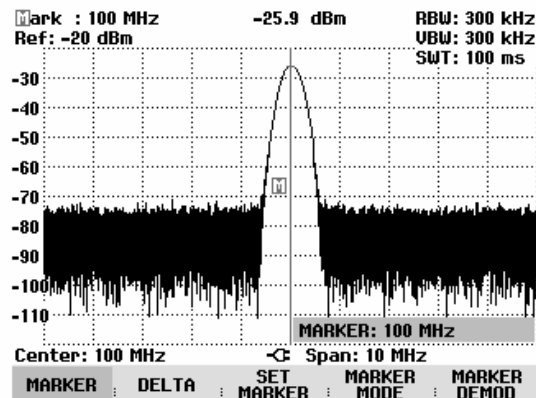

**Controlling the delta marker:**

- Press the MARKER key.
- Press the DELTA softkey.

The R&S FSH3-TV turns on the delta marker and places it on the second largest signal on the trace. The frequency and level displayed at the top of the screen are relative to the main marker, i.e. the R&S FSH3-TV always outputs the frequency difference and the level difference between the points marked by the main marker and the delta marker. Simultaneously, the value entry box for the delta marker frequency difference is opened.

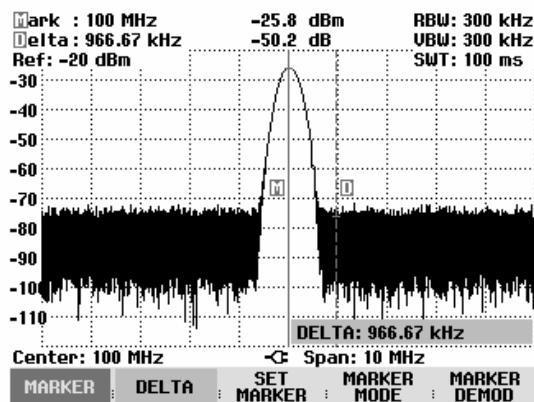

The following actions can now be performed:

- Change the delta marker position with the rotary knob or the cursor keys.
- Enter a delta marker position with the number keys and confirm with a unit key.
- Confirm the delta marker position by pressing the ENTER key or the DELTA MARKER softkey.

**Automatic marker positioning**

The R&S FSH3-TV has functions that make setting markers easier or allow instrument settings to be made on the basis of the current marker position:

- **PEAK**      This function places the marker or the delta marker on the highest value of the trace. The function acts on the active marker, whose associated softkey labelling is highlighted in red.
- **NEXT PEAK**      Relative to their current positions, this function places the marker or the delta marker on the next highest peak of the trace.
- **MINIMUM**      The marker or delta marker is placed on the lowest value of the trace. The function acts on the active marker. When the trace is displayed in the CLEAR/WRITE mode, the marker is placed on the lowest maximum of the trace.
- **CENTER = MRK FREQ**      When this function is called, the center frequency (CENTER) is made equal to the current marker frequency or the delta marker frequency, depending on which marker is activated (softkey label highlighted in red). This function is particularly useful if you want to investigate a signal more closely using a smaller span. This is accomplished by first placing the signal in the center of the span and then reducing the span.
- **REF LVL = MRK LVL**      This function makes the level indicated by the marker the reference level. This makes it easy to optimize the R&S FSH3-TV's level display range if the levels being investigated are low.

**Operating sequence:**

- Press the MARKER key.
- Press the SET MARKER softkey.
- Using the cursor keys or the rotary knob, select the function you want.
- Confirm your selection with the ENTER key or the SET MARKER softkey.

The R&S FSH3-TV then performs the action you have selected.

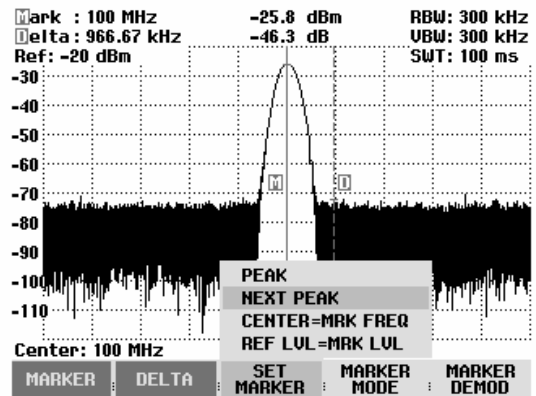

The R&S FSH3-TV allows you to use only a limited section of the trace for the PEAK, NEXT PEAK and MINIMUM functions. This is beneficial, for example, if you want to sample only spurious emissions with the marker search functions and want to omit useful signals.

- Press the SET MARKER softkey.
- Using the rotary knob or the cursor keys, select SEARCH RANGE LIMITS.
- Confirm your choice with the SET MARKER softkey or the ENTER key.

The R&S FSH3-TV opens a submenu for setting the start and stop frequencies for the marker search range.

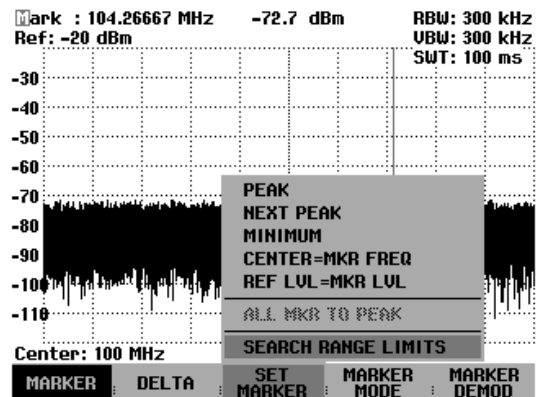

- For entering the start of the search range, select the START SEARCH menu item with the rotary knob or the cursor keys and confirm your choice by pressing the SET MARKER softkey or the ENTER key.

The R&S FSH3-TV opens the entry field for the start frequency of the search range.

- Enter a start frequency with the numeric keys and terminate the entry with the desired unit or change the start frequency with the rotary knob or the cursor keys and terminate the entry with the ENTER key.

The R&S FSH3-TV indicates the start of the search range by means of a dashed vertical line in the diagram.

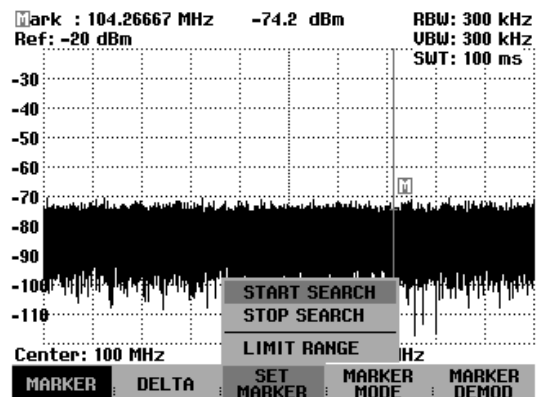

The procedure for entering the stop frequency for the search range is analogous to that for entering the start frequency.



### Deactivating the marker search range:

If a marker search range is activated, the LIMIT RANGE menu item in the SEARCH RANGE LIMITS menu is highlighted in green.

- Press the SET MARKER softkey to deactivate the marker search range.
- Using the rotary knob or the cursor keys, select SEARCH RANGE LIMITS.
- Confirm your entry with the SET MARKER softkey or the ENTER key.
- Select the LIMIT RANGE menu item using the cursor keys or the rotary knob.
- Deactivate the search in the limited range using the SET MARKER softkey or the ENTER key.

If you call up the SEARCH RANGE LIMITS menu again, the LIMIT RANGE menu item is no longer highlighted.

### Using more than one marker at a time (multimarker mode)

To measure different signals in a trace, the R&S FSH3-TV has the multimarker function. Up to six different markers are available in the multimarker mode. Marker 1 measures in absolute units. Markers 2 to 6 can measure in absolute units (marker) as well as relative units (delta). The reference for delta markers is always marker 1.

#### Operating sequence:

- Press the MARKER key.
- Press the MARKER MODE softkey.
- Using the cursor keys or the rotary knob, select MULTI MARKER... from the submenu.
- Confirm your selection with the ENTER key or the MULTI MARKER softkey.

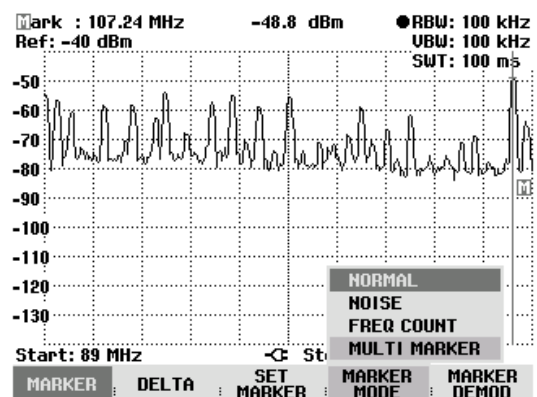

The R&S FSH3-TV is now in multimarker mode.

Except for the MARKER DEMOD softkey that is replaced by the MKR LIST VIEW softkey in multimarker mode, this menu is identical to the standard marker menu. The marker designation contains the number of the marker in question (M becomes M1, D becomes D2). The active marker or delta marker is displayed with its number (e.g. M1: or D2:) and the frequency and level at the upper-right hand corner of the screen.

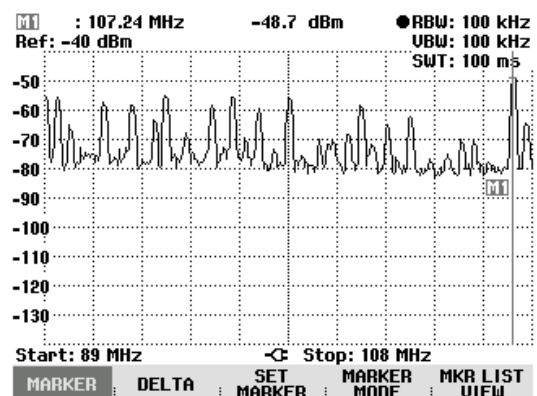

- Press the MARKER or DELTA softkey.

The R&S FSH3-TV opens a list for selecting the marker or delta marker to be edited. The markers that are already switched on are highlighted in green. The (delta) marker numbers already allocated to a (delta) marker are deactivated, i.e. greyed out.

- Using the rotary knob or the cursor keys, select the marker or delta marker you want and confirm your selection with the ENTER key or the MARKER or DELTA softkey.

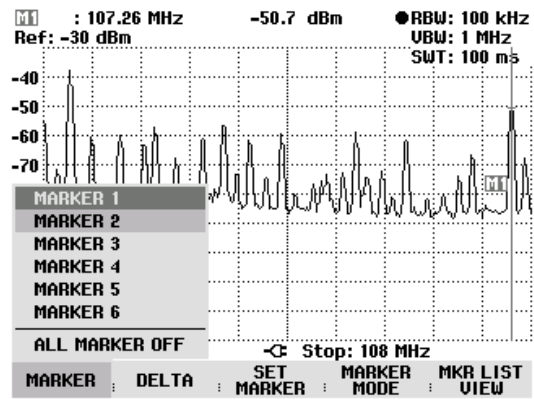

The R&S FSH3-TV opens the entry box for the frequency of the selected marker or the spacing between the delta marker and the reference marker M1.

- Using the cursor keys, place the marker or delta marker near the position you want. The step width here is 10 % of the X axis.
- Then use the rotary knob to fine-tune the marker or delta marker to the signal. The step width corresponds to the pixel spacing of the trace.
- Alternatively, enter the desired position of the marker or delta marker using the number keys and terminate the entry with one of the unit keys.

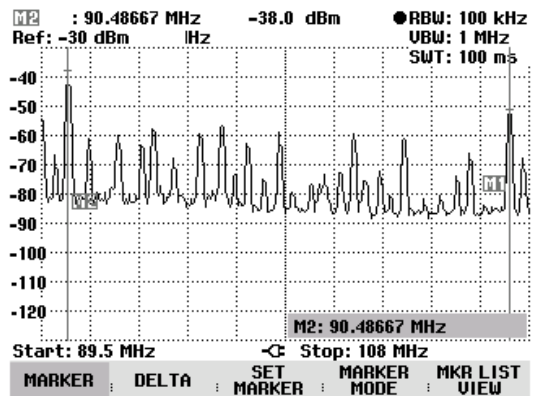

The R&S FSH3-TV displays the marker or delta marker last edited in the marker readout box at the upper left-hand corner of the screen. All marker functions in the SET MARKER menu apply to the displayed markers.

**Automatic marker positioning:**

Automatic positioning of markers in multimarker mode is similar to that of the normal marker. The different functions always apply to the active marker, which is also indicated for the various functions in the SET MARKER menu (example: "M2; PEAK").

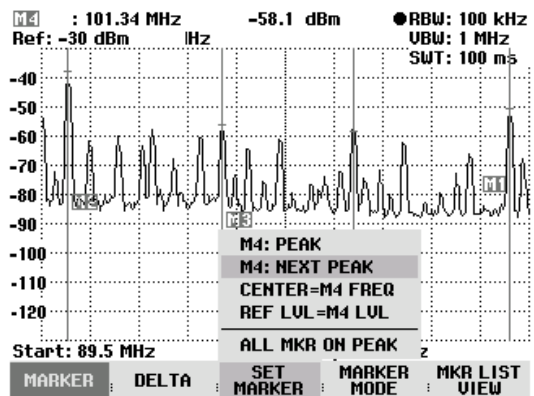

In addition, it is possible to position all activated markers (M1 to M6) at the peak of a trace.

- In the SET MARKER menu, select ALL MKR TO PEAK and confirm this with the ENTER key or the SET MARKER softkey.

The R&S FSH3-TV sets all activated markers to the maxima of the trace. The delta markers remain unaffected by this function.

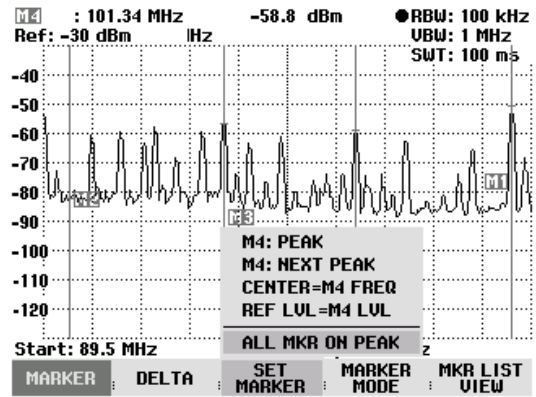

**Displaying all multimarker values:**

The R&S FSH3-TV can display a list of all activated markers and their values.

- Press the MKR LIST VIEW softkey.

The R&S FSH3-TV displays a list of all activated markers and delta markers.

If you press the MKR LIST VIEW softkey again or any other softkey in the marker menu, the R&S FSH3-TV closes the marker table.

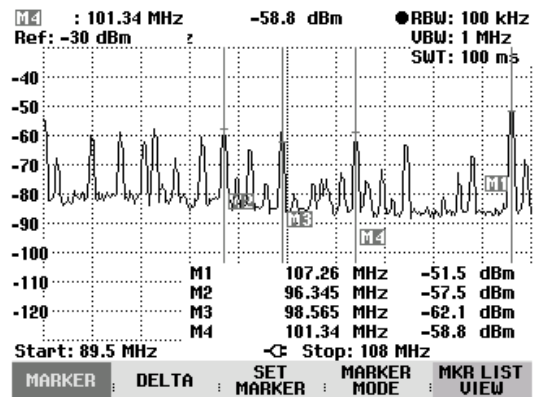

**Deactivating markers:**

In multimarker mode, markers can be deactivated one at a time or all at once.

**Deactivating markers or delta markers one at a time:**

- Press the MARKER or DELTA softkey.

The activated markers or delta markers are highlighted in green.

- Using the rotary knob or the cursor keys, select an activated marker or delta marker, i.e. place the red cursor on the appropriate item.

The value entry box for the selected marker appears.

- Press the MARKER or DELTA softkey to deactivate the selected marker or delta marker.

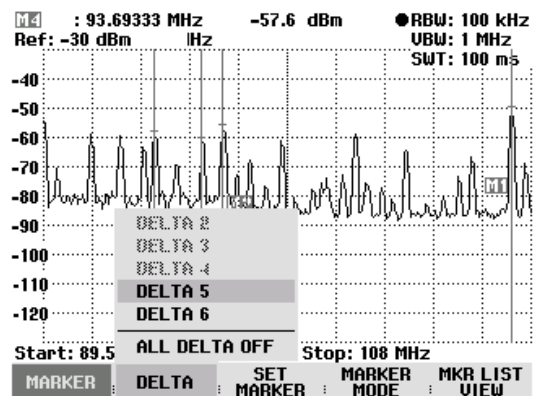

*Note: If marker 1 (M1) is deactivated, the R&S FSH3-TV also deactivates all delta markers, because they use marker 1 as a reference.*

**Deactivating all markers or delta markers:**

- Press the MARKER or DELTA softkey.
- Using the rotary knob or the cursor keys, select ALL MARKERS OFF or DELTA OFF.
- Press the ENTER key or the MARKER or DELTA softkey to deactivate all markers or delta markers.

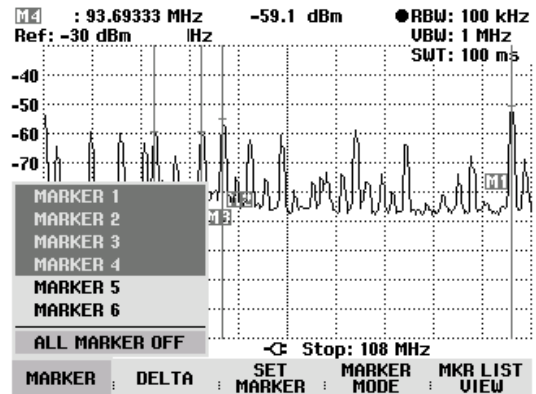

*Note: When the markers are deactivated, the R&S FSH3-TV also deactivates all delta markers, because they use marker 1 as a reference.*

**Exiting the multimarker mode:**

- Press the MARKER key.
- Press the MARKER MODE softkey.
- Using the cursor keys or the rotary knob, select NORMAL, NOISE or FREQ COUNT from the submenu.
- Confirm your selection with the ENTER key or the MARKER MODE softkey.

The R&S FSH3-TV returns to the normal marker mode.

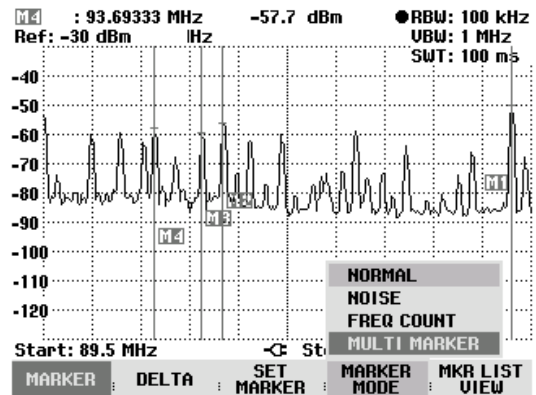

The R&S FSH3-TV transfers the settings of the multimarker and multi delta marker with the lowest numbers to the normal marker mode.

Alternatively, you can exit the multimarker mode by deactivating all markers (MARKER key: MARKER softkey: ALL MARKERS OFF menu item) or with PRESET.

## Marker functions

Apart from displaying the level and frequency at the marker position (NORMAL setting), the R&S FSH3-TV can also perform other forms of analysis at the marker position. For example, the R&S FSH3-TV can calculate the noise power density referred to 1 Hz bandwidth (NOISE function) or measure the frequency of a signal at the marker position (FREQ COUNT function).

## Measuring the noise power density

The NOISE function is used to calculate the noise power density at the marker position. The R&S FSH3-TV calculates the noise power density in dBm/(1 Hz) from the trace pixel values, the selected resolution bandwidth, the detector and the level display mode (absolute or relative). To stabilize the noise power display, the R&S FSH3-TV uses the pixel on which the marker is positioned and the four pixels to the right and the four pixels to the left of the marker pixel. Noise power density can provide useful information when measurements are made on noise or digitally modulated signals. However, valid results are obtained only if the spectrum in the vicinity of the marker has a flat frequency response. The function gives incorrect results if measurements are made on discrete signals.

### Operating sequence:

- Press the MARKER key.
- Press the MARKER MODE softkey.
- Using the cursor keys or the rotary knob, select the NOISE menu item.
- Confirm the selection with the ENTER key or by pressing the MARKER MODE softkey again.

The R&S FSH3-TV now indicates the marker level in dBm/Hz. If the delta marker is the active marker, it displays the result in dBc/Hz. The reading is referred to the main marker.

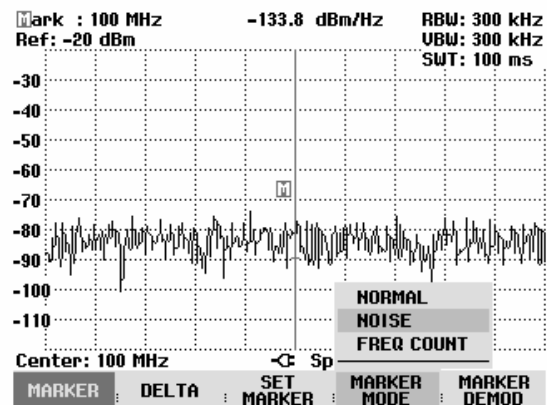

## Measuring the frequency

The **FREQ COUNT** function is used to measure the frequency at the marker position. The accuracy of the marker frequency readout is then no longer dependent on the pixel resolution of the trace, but only on the accuracy of the internal reference frequency.

The R&S FSH3-TV calculates the marker frequency from the center frequency, the span and the frequency of the trace pixel on which the marker is positioned. The trace has 301 pixels corresponding to 301 frequency coordinates. The frequency resolution is therefore relatively coarse – especially if a large span is set. To circumvent this problem, the R&S FSH3-TV's internal frequency counter can be used. When frequency measurements are being made, the R&S FSH3-TV briefly stops the sweep at the marker position and measures the frequency using the frequency counter. The resolution of the frequency counter is 1 Hz and so is considerably higher than the resolution that is obtained without the **FREQ COUNT** function. Even though the resolution is high, frequency counting is extremely fast thanks to a special algorithm for the IQ baseband signal (approx. 30 ms at a resolution of 1 Hz). Basically, the accuracy of the frequency readout depends only on the accuracy of the internal reference frequency (TCXO).

The frequency counter only gives completely accurate readings for sine signals that are at least 20 dB above the noise floor. If the S/N ratio is less, noise affects the results.

### Operating sequence:

- Press the **MARKER** key.
- Press the **MARKER MODE** softkey.
- Using the cursor keys or the rotary knob, select the **FREQ COUNT** menu item.
- Confirm the selection with the **ENTER** key or by pressing the **MARKER MODE** softkey again.

The R&S FSH3-TV now displays the counted marker frequency with a resolution of 1 Hz. To indicate that the **FREQ COUNT** function is on, **Count** in the top left corner of the screen changes to 'Count':.

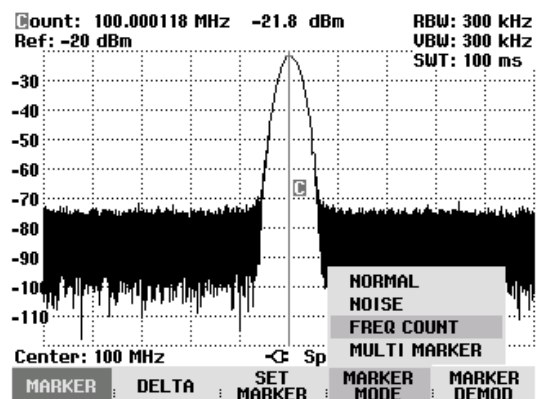

## AF demodulation

The R&S FSH3-TV has an AM and FM demodulator for audiomonitoring signals. The demodulated AF signal can be listened to with headphones (supplied accessories). The headphones are connected to the 3.5 mm jack on the left-hand side of the carrying handle. As the R&S FSH3-TV makes the uncontrolled video voltage audible in the case of AM demodulation, it is advisable to set the reference level so that the level of the signal to be demodulated is near the reference level.

When spectrum measurements are being made, the R&S FSH3-TV demodulates the signal at the marker frequency for a settable period of time. The sweep stops at the marker frequency for the demodulation period and then continues. If time-domain measurements are being made (span = 0 Hz), the R&S FSH3-TV performs continuous demodulation.

**Operating sequence:**

- Press the MARKER key.
- Press the MARKER DEMOD softkey.

The submenu for setting demodulation parameters opens. If no markers have been activated, the R&S FSH3-TV automatically turns on the marker and positions it on the trace maximum.

- Using the cursor keys or the rotary knob, select the demodulation mode (AM or FM) you want and confirm your selection with the ENTER key.

*Note:* When the AF demodulation mode is selected, the R&S FSH3-TV automatically turns off the noise marker or the frequency counter.

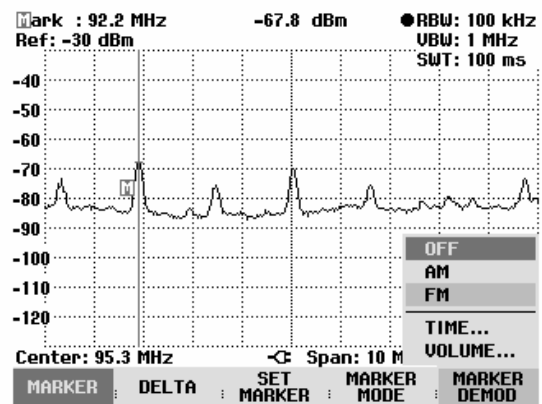

- To enter the demodulation time, select the TIME... item in the menu.

The currently set demodulation time is displayed in the value entry box. The demodulation time range is 100 ms to 500 s. If the R&S FSH3-TV is set to span = 0 Hz, the demodulation time setting is irrelevant as continuous demodulation is always performed.

- Change the time with the cursor keys or the rotary knob or enter a time using the number keys and confirm with the ENTER key.
- To adjust the volume, select the VOLUME... menu item and confirm your selection with the ENTER key.

The R&S FSH3-TV displays the volume in % in the value entry box. The volume range is 0 % (very low) to 100 % (full volume).

- Using the cursor keys or the rotary knob, adjust the volume or enter the volume in % using the number keys and confirm with the ENTER key.

To indicate that AF demodulation is on, the softkey label MARKER DEMOD is highlighted in green when you quit the submenu.

## Using the Display Line

In addition to the markers, the R&S FSH3-TV provides a horizontal line for determining the signal level in the display.

- Press the MEAS key.
- Press the DISPLAY LINE softkey.

The R&S FSH3-TV displays a horizontal line across the entire diagram. To distinguish it from other lines, it is labelled 'L'. The Y position of the line is indicated at the top left of the diagram (Line: -53 dBm in the diagram shown at the right).

- The line can be moved in the Y direction with the cursor keys or the rotary knob, or a level position can be entered with the numeric keys.

Terminate the entry with the ENTER key.

The softkey label DISPLAY LINE is printed on a green background and the entry box is cleared.

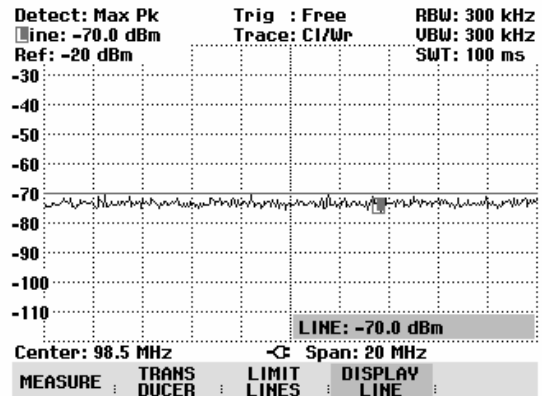

In contrast to the markers, the position of the displayed line is pixel-oriented. The line resolution in the Y direction therefore depends on the measurement range set in the Y direction. For a display range of 100 dB, it is 0.5 dB. When the line is set with the rotary knob, the R&S FSH3-TV always uses the step width of the display resolution in the Y direction, e.g. 0.5 dB for a 100 dB level measurement range. The cursor keys, on the other hand, always move the line by 10 % of the display range in the Y direction. For fast setting of the display line, we therefore recommend to set the line near the desired position with the cursor keys and then to use the rotary knob for fine adjustment.



## Operation as an Analog TV Receiver

The R&S FSH3-TV demodulates and decodes analog TV signals in compliance with the B, G, H, D, K, I, L, M and N standards. The instrument demodulates and decodes sound carrier signals using the FM stereo IRT-A2, FM stereo Korea, NICAM, BTSC and EIA-J transmission techniques.

Four modes are available for displaying the measurement results:

- **Measurement List**  
The measurement parameter list provides an overview of the presence and quality of the set receive channel.
- **Video Scope**  
The demodulated video signal is displayed.
- **Carrier Measurements**  
The level and frequency parameters for the vision and sound carriers are measured.
- **Vision Modulation**  
The modulation depth and residual carrier of the vision carrier are measured.
- **Hum Measurement**  
The hum modulation of the vision carrier is measured.

The R&S FSH3-TV measures the video transmission parameter in the test lines which are transmitted with the TV signal in the vertical blanking interval.

In the Measurement List and Video Scope modes, the R&S FSH3-TV provides the demodulated video signal clamped to the black level on the instrument's BNC jack.

The decoded audio signals are available in the Measurement List and Video Scope modes on the headphone jack.

### Switching on the analog TV receiver and selection of the operating mode:

- Press the MEAS key.
- Press the MEASURE softkey.

The R&S FSH3-TV will open the menu for the measurement functions.

- Using the cursor keys or the rotary knob, select ANALOG TV RECEIVER from the menu and confirm your choice with the ENTER key or the MEASURE softkey.

The R&S FSH3-TV will open the menu for selection of the operating mode.

- Using the cursor keys or the rotary knob, select the desired operating mode and confirm your choice with the ENTER key or the SELECT MEASURE softkey.

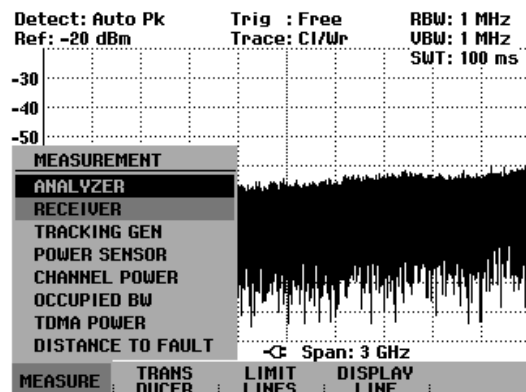

## Setting the Analog TV Standard

The R&S FSH3-TV is capable of demodulating and decoding the most common analog TV standards. The user can set the appropriate analog TV standard. The selection is then valid in all of the operating modes and is retained even in case of an instrument preset.

- Press the SETUP key.
- Press the LOCAL SETTINGS softkey.
- Using the cursor keys or the rotary knob, select ANALOG TV STANDARD from the menu and confirm your choice with the ENTER key or the LOCAL SETTINGS softkey.

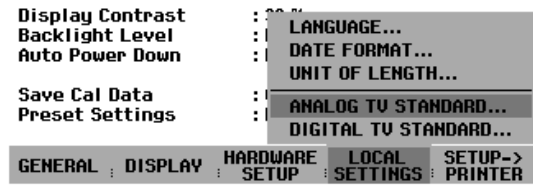

The analog TV standard is set in three steps. First, the standard is set which determines the channel bandwidth, the vision modulation, the frame frequency and the line numbering.

- Using the cursor keys or the rotary knob, select the STANDARD and confirm your choice with the ENTER key or the LOCAL SETTINGS softkey.



The second step involves selection of the group delay characteristic for use in equalizing the demodulated video signal.

- Using the cursor keys or the rotary knob, select the group delay characteristic and confirm your choice with the ENTER key or the LOCAL SETTINGS softkey.

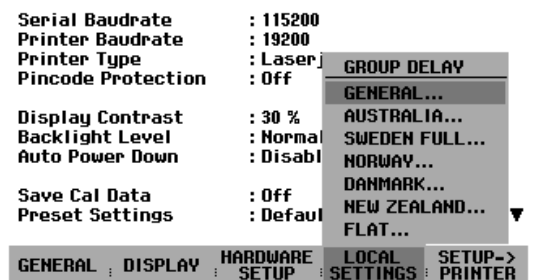

The third step involves selection of the sound transmission standard for use in demodulating and decoding the sound carriers.

- Using the cursor keys or the rotary knob, select the sound transmission standard and confirm your choice with the ENTER key or the LOCAL SETTINGS softkey.

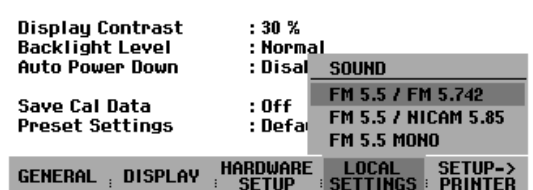

The table below lists the possible settings for the analog TV standard as supported by the R&S FSH3-TV.

<b>Standard</b>	<b>Group delay characteristic</b>	<b>Sound transmission standard</b>
B	GENERAL AUSTRALIA SWEDEN FULL NORWAY DANMARK NEW ZEALAND FLAT	FM 5.5 / FM 5.742 FM 5.5 / NICAM 5.85 FM 5.5 MONO
G/H	GENERAL AUSTRALIA SWEDEN FULL NORWAY DANMARK NEW ZEALAND FLAT	FM 5.5 / FM 5.742 FM 5.5 / NICAM 5.85 FM 5.5 MONO
D/K	CCIR OIRT FLAT	FM 6.5 / FM 6.742 FM 6.5 / FM 6.258 FM 6.5 / NICAM 5.85 FM 6.5 MONO
M/NTSC	FCC FLAT	FM 4.5 BTSC FM 4.5 EIA-J FM 4.5 / FM 4.724 FM 4.5 MONO
M/PAL	FCC FLAT	FM 4.5 BTSC FM 4.5 EIA-J FM 4.5 / FM 4.724 FM 4.5 MONO
N	FCC FLAT	FM 4.5 BTSC FM 4.5 EIA-J FM 4.5 / FM 4.724 FM 4.5 MONO
I	FLAT	FM 6.0 / NICAM 6.552 FM 6.0 MONO
L	TDF FLAT	AM 6.5 / NICAM 5.85 AM 6.5 MONO

## Setting the Receive Frequency

You can set the frequency by entering the vision carrier frequency, the channel center frequency or the channel number for the selected channel table.

### Setting the vision carrier frequency:

- Press the **FREQ** key.
- Press the **VISION CARRIER** softkey.

The R&S FSH3-TV opens the entry field for setting the vision carrier frequency.

- Use the rotary knob, the cursor keys or a numerical entry to set or change the vision carrier frequency.

Any change in the frequency setting when using the rotary knob will depend on the setting for the **FREQ STEPSIZE**.

### Setting the channel center frequency:

- Press the **FREQ** key.
- Press the **CHANNEL CTR FREQ** softkey.

The R&S FSH3-TV opens the entry field for setting the channel center frequency.

- Use the rotary knob, the cursor keys or a numerical entry to change the channel center frequency.

Any change in the frequency setting when using the rotary knob will depend on the setting for the **FREQ STEPSIZE**.

The R&S FSH3-TV computes the vision carrier frequency based on the settings for the standard and the sideband.

Sideband	Computation of the vision carrier frequency
Upper sideband	Vision carrier frequency = channel center frequency – channel bandwidth / 2 + 1.25MHz
Lower sideband	Vision carrier frequency = channel center frequency + channel bandwidth / 2 - 1.25MHz

The channel bandwidth is dependent on the standard.

TV standard	Channel bandwidth
M/NTSC, M/PAL, N	6 MHz
B	7 MHz
G/H, D/K, I, L	8 MHz

**Setting the frequency stepsize:**

You can set the stepsize for use in setting the frequency with the rotary knob. In the default setting, the stepsize is dependent on the channel bandwidth (which is dependent on the standard).

- Press the **FREQ** key.
- Press the **FREQ STEPSIZE** softkey.

The R&S FSH3-TV opens the entry field for inputting the frequency stepsize.

- Enter the desired stepsize in the entry box using the numeric keypad and terminate the entry with the appropriate unit key. Alternatively, the stepsize can be changed with the rotary knob or the cursor keys.

ANALOG TV RECEIVER				
TV Std. - Group Delay	G/H - GENERAL			
Sound Standard	FM 5.5 / FM 5.742			
Vision Carrier Frequency	471.75 MHz			
Channel	21			
Reference Level	-15 dBm		(0 dB)	
<hr/>				
Vision Carrier Level	-21.3 dBm			
Carrier Frequency Offset	-510 kHz			
Vision Detector	LOCKED			
Sync Separator	H+V SYNC			
Luminance Bar	708.1 mV			
S/N Video Weighted(bar/nom)	53.1 dB / 53.0 dB			
FM Deviation Snd Carrier 1	30.0 kHz			
FM Deviation Snd Carrier 2	30.0 kHz			
FM Mode	STEREO			
	STEP: 8 MHz			
	←			
CHANNEL	VISION	FREQ	CHANNEL	CHANNEL
CTR FREQ	CARRIER	STEPSIZE		TABLE

## Frequency Tuning in Channel Spacings

As an alternative to frequency input, the R&S FSH3-TV allows you to tune the frequency using channel spacings. A simple channel table can be defined directly from the R&S FSH3-TV's front panel. Complicated channel tables, e.g. ones with gaps in the channel numbers or the frequency, must be defined using the R&S FSH View software and loaded into the R&S FSH3-TV's memory.

- Press the **FREQ** key.
- Press the **CHANNEL** softkey.

The R&S FSH3-TV opens the entry field for inputting the channel number. Set the frequency corresponding to the selected channel table.

- Enter the desired channel number in the entry box using the numeric keypad and terminate the entry with the **ENTER** key. Alternatively, the channel number can be changed with the rotary knob or the cursor keys.

If you try to enter a channel outside of the defined range, the R&S FSH3-TV displays "Range exceeded".

*Note: The channel table shows the reference between a channel number and channel center frequency. The R&S FSH3-TV computes the vision carrier frequency based on the settings for the standard and the sideband.*

A channel table is selected as follows:

- Press the **CHANNEL TABLE** softkey.

The R&S FSH3-TV switches to the submenu for selecting the channel configuration. All channel tables available in the instrument that were loaded with the R&S FSH3-TV View software are displayed. If no channel table is loaded, the R&S FSH3-TV displays "No bands available".

- Select the desired channel table using the rotary knob or the cursor keys.
- Confirm your selection with the **SELECT** softkey.

The R&S FSH3-TV will switch back to the measurement screen.

30/03/2004	BAND TABLE LIST	22:10:16
<b>TU France</b>	<b>01/03/2004 15:59:02</b>	
TU Japan	01/03/2004 14:58:52	
TU DK_DIRT	01/03/2004 14:40:20	
TU Australia	01/03/2004 14:40:08	
TU Europe	01/03/2004 14:39:56	
TU China	01/03/2004 14:34:40	
TU Italy	01/03/2004 14:30:40	
TU Ireland	01/03/2004 14:30:26	
TU French Overs	01/03/2004 14:30:16	
PCS UL	01/01/1995 02:00:00	
PCS DL	01/01/1995 02:00:00	
GSM UL	01/01/1995 02:00:00	
GSM DL	01/01/1995 02:00:00	

<b>SELECT</b>	<b>SELECT</b>	<b>EXIT</b>	<b>DEF</b>	<b>LIST-&gt;</b>
: USER TAB :	: USER TAB :		: USER TAB :	: PRINTER

If no channel table is stored in the instrument or a different one is necessary, a user table can also be defined.

To define a user table, proceed as follows:

- Press the **FREQ** key.
- Press the **CHANNEL TABLE** softkey.
- Press the **SELECT USER TAB** softkey.
- Press the **DEFINE USER TAB** softkey.

The R&S FSH3-TV opens the submenu for entering the different parameters of the channel table. A channel table is defined by the number used for the first channel and the associated frequency, and by the number of channels and their frequency spacing.

30/03/2004	BAND TABLE LIST	22:15:14
TU France	01/03/2004 15:59:02	
TU Japan	01/03/2004 14:58:52	
TU DK_OIRT	01/03/2004 14:40:20	
TU Australia	01/03/2004 14:40:08	
<b>TU Europe</b>	<b>01/03/2004 14:39:56</b>	
TU China	01/03/2004 14:34:40	
TU Italy	01/03/2004 14:30:40	
TU Ireland	01/03/2004 14:30:26	
TU French Overs	01/03/2004 14:30:16	
PCS UL	01/01/1995 02:00:00	
PCS DL	01/01/1995 02:00:00	
GSM UL	<b>1ST CHANNEL NO...</b>	
GSM DL	<b>1ST CHANNEL FREQ...</b>	
	<b>NO OF CHANNELS...</b>	
	<b>CHANNEL SPACING...</b>	
SELECT	<b>SELECT USER TAB</b>	EXIT
	DEFINE USER TAB	LIST->
		PRINTER

- Select **1<sup>ST</sup> CHANNEL NO...** by pressing the **ENTER** key.
- Enter the number of the first channel and confirm the entry with the **ENTER** key.
- Press the **DEFINE USER TAB** softkey.
- Select **1<sup>ST</sup> CHANNEL FREQ...** from the menu and confirm with the **ENTER** key.
- Enter the frequency of the first channel and terminate the entry with the frequency unit.
- Press the **DEFINE USER TAB** softkey.
- Select **NO OF CHANNELS...** from the menu and confirm with the **ENTER** key.
- Enter the number of channels and confirm the entry with the **ENTER** key.
- Press the **DEFINE USER TAB** softkey.
- Select **CHANNEL SPACING...** from the menu and confirm with the **ENTER** key.
- Enter the channel spacing for the channels and terminate the entry with the required unit key.

## Selecting the Sideband

The R&S FSH3-TV can demodulate either the upper or the lower sideband. During automatic operation, this sideband is set according to the selected standard. With one exception, the normal sideband is always the upper sideband for all of the standards. The lower sideband is demodulated only for L standard in case of channel center frequencies below 65 MHz.

- Press the **BW** key.
- Press the **SIDEBAND POSITION** softkey.
- Using the cursor keys or the rotary knob, select the desired setting and confirm your choice with the **ENTER** key or the **SIDEBAND POSITION** softkey.

FM Deviation Snd Carrier 1	30.0 kHz	<b>AUTO</b>
FM Deviation Snd Carrier 2	30.0 kHz	
FM Mode	STEREO	
←		<b>UPPER</b>
		<b>LOWER</b>
		<b>SIDEBAND POSITION</b>

## Manual Setting of the Reference Level

The reference level (REF LEVEL) controls the sensitivity of the analog TV receiver. Set the reference level so that the receiver is neither overdriven nor underdriven. The R&S FSH3-TV measures the signal-to-noise ratio and displays it in the MEASUREMENT LIST mode.

There is no fixed relationship between the useful received level and the reference level setting since the optimum setting is dependent on the overall received signal. The reference level is set in the AMPT menu.

- Press the AMPT key.
- Press the REF LEVEL softkey.
- Change the reference level setting with the cursor keys or the rotary knob, or enter a new reference level via the numeric keypad.
- Enter a reference level with the number keys and either terminate the entry with one of the unit keys (-dBm or dBm for relative measurements or (), m,  $\mu$ , n for absolute measurements) or press the ENTER key, or
- Change the reference level with the rotary knob or the cursor keys.

## Selecting the Reference Level Unit

The reference level can be entered in dBm, dB $\mu$ V, dBmV, V or W.

- Press the AMPT key.
- Press the UNIT softkey.
- Change the reference level setting with the cursor keys or the rotary knob, or enter a new reference level via the numeric keypad.

## Entering the Reference Offset

- Press the AMPT key.
- Press the REF OFFSET softkey.
- Using the number keys, enter a reference offset and terminate the entry with one of the unit keys or the ENTER key, or
- Change the reference level with the rotary knob or the cursor keys.

The reference offset unit is always dB – no matter what unit is used for the reference level.

To indicate that a non-zero reference offset has been set, the R&S FSH3-TV places a red circle before the reference level readout.



### Entering the Input Impedance

- Press the AMPT key.
- Press the RF INPUT softkey.

A submenu opens and the two input impedance options “50 Ω” and “75 Ω” are displayed.

- Using the rotary knob or the cursor keys, select the input impedance you want and confirm your selection by pressing the ENTER key.

*Note: If the input is set to 75 Ω, you will definitely need a matching element on the RF input. Otherwise, the R&S FSH3-TV will display the wrong level.*

ANALOG TV RECEIVER				
TV Std. - Group Delay	G/H - GENERAL			
Sound Standard	FM 5.5 / FM 5.742			
Vision Carrier Frequency	471.25 MHz			
Channel	21			
Reference Level	-20 dBm	(1 dB)		
Vision Carrier Level	-21.2 dBm			
Carrier Frequency Offset	0 kHz			
Vision Detector	LOCKED			
Sync Separator	H+U SYNC			
Luminance Bar	707.1 mV			
S/N Video Weighted(bar/nom)	55.1 dB / 55.0 dB			
FM Deviation Snd Carrier 1	30.0 kHz			
FM Deviation Snd Carrier 2	30.0 kHz			
FM Mode	STEREO			
			50 Ω	
			75 Ω	
REF LEVEL	RANGE	UNIT	REF OFFSET	RF INPUT

### Inputting the Display Range

In the Vision Modulation and Hum Measurement operating modes, you can set the scaling. Linear scaling is the default.

- Press the AMPT key.
- Press the RANGE softkey.

A menu box opens on the R&S FSH3-TV and the various options for scaling the level axis are displayed.

- Using the rotary knob or the cursor keys, select the scaling option you want and confirm your selection by pressing the ENTER key.

The R&S FSH3-TV automatically sets the desired scaling.

### Setting the Unit for the Video Amplitude

Either mV or IRE can be selected for the Luminance Bar video parameter and the scaling of the video scope. You can make this setting in the Measurement List or Video Scope operating mode.

- Press the MEAS key until the F1 function key displays SELECT MEASURE.
- Press the LEVEL softkey.
- Using the rotary knob or the cursor keys, select the unit you want and confirm your choice with the ENTER key or the LEVEL softkey.

ANALOG TV RECEIVER				
TV Std. - Group Delay	G/H - GENERAL			
Sound Standard	FM 5.5 / FM 5.742			
Vision Carrier Frequency	471.25 MHz			
Channel	21			
Reference Level	-20 dBm	(1 dB)		
Vision Carrier Level	-21.2 dBm			
Carrier Frequency Offset	0 kHz			
Vision Detector	LOCKED			
Sync Sep	H+U SYNC			
Luminanc	707.4 mV			
S/N Video	55.0 dB / 54.9 dB			
FM Devia	30.0 kHz			
FM Devia	30.0 kHz			
FM Mode	STEREO			
	LEVEL ADJUST			
	dBm			
	dBmU			
	dBμV			
	IRE			
	mV			
SELECT MEASURE	LEVEL	SET TEST LINE	AUDIO SOURCE	VOLUME

## Automatic Routine for Setting the Optimum Reference Level

To simplify operation and to prevent incorrect measurements, the R&S FSH3-TV has an automatic routine for setting the reference level.

In the Parameter List and Video Scope operating modes, the LEVEL ADJUST function measures the signal-to-noise ratio of the demodulated video signal as a function of the reference level and sets the reference level at which the optimum signal-to-noise ratio of the demodulated video signal is attained. This ensures that the receiver is optimally set, irrespective of the channels and levels of the input signal.

In the Vision Modulation and Carrier Measurements operating modes, the LEVEL ADJUST function measures the maximum vision carrier power and sets the reference level accordingly.

### Launching the Level Adjust routine:

- Press the MEAS key.
- Press the LEVEL softkey.
- Using the rotary knob or the cursor keys, select LEVEL ADJUST and confirm your choice with the ENTER key or the LEVEL softkey.

## Measuring the Video Transmission Parameters Using Test Line Measuring Equipment

The R&S FSH3-TV measures the video transmission parameters in the test lines which are transmitted in the vertical blanking interval of the transmitted signal.

These measurements are made in the test lines CCIR 17, NTC7 COMP, FCC COMP and the QUIET LINE.

The positions of the test lines within the picture (line number) must be matched to the received signal. **This is the only way of correctly measuring the video parameters.**

The table shows the test lines that the video parameters are measured in as a function of the standard.

Video parameter	Test line	
	B, G, H, D, K, I, N, L standards	M/NTSC, M/PAL standards
Luminance bar	CCIR 17	NTC7 COMP / FCC COMP
S/N video weighted (bar)	CCIR 17 und QUIET LINE	NTC7 COMP / FCC COMP and QUIET LINE
S/N video weighted (nom)	QUIET LINE	QUIET LINE
Modulation depth	CCIR 17	NTC7 COMP / FCC COMP
Residual picture carrier	CCIR 17	NTC7 COMP / FCC COMP
Bar amplitude	CCIR 17	NTC7 COMP / FCC COMP
Sync amplitude	CCIR 17	NTC7 COMP / FCC COMP

## Test Lines

The test line signals are scanned to compute the video parameters. The following section describes the values which are used in this computation.

### CCIR 17 test line

The white level is measured 17  $\mu\text{s}$  after the synchronization pulse and the black level 37  $\mu\text{s}$  after the synchronization pulse.

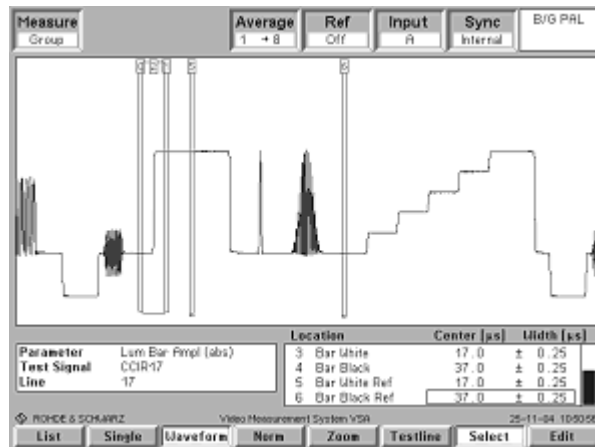

### CCIR 330 test line

The white level is measured 17  $\mu\text{s}$  after the synchronization pulse and the black level 37  $\mu\text{s}$  after the synchronization pulse.

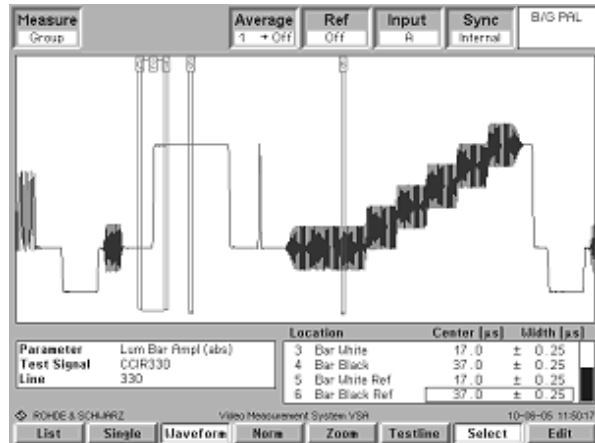

### NTC7 COMP test line

The white level is measured 20.8  $\mu\text{s}$  after the synchronization pulse and the black level 40.5  $\mu\text{s}$  after the synchronization pulse.

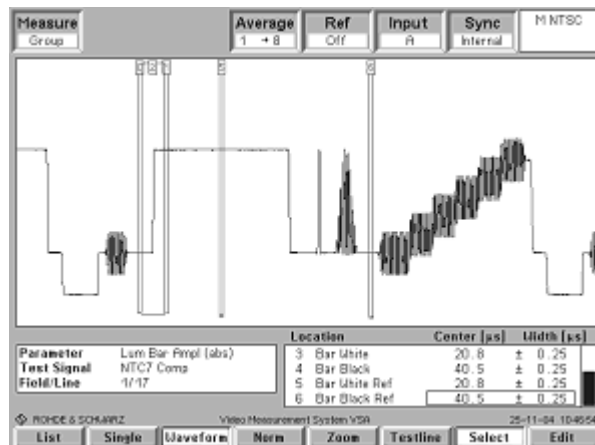

**FCC COMP test line**

The white level is measured 52.5  $\mu$ s after the synchronization pulse and the black level 41.7  $\mu$ s after the synchronization pulse.

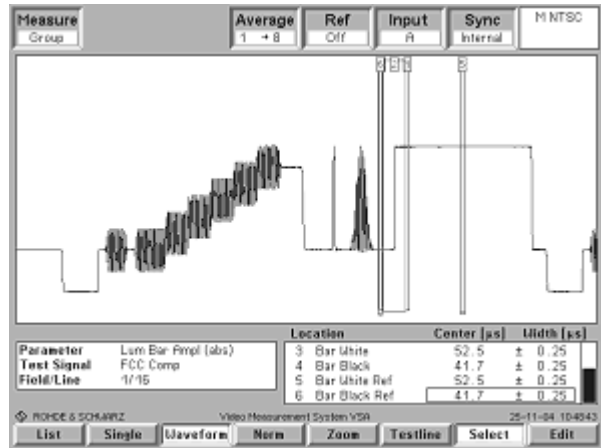

**QUIET LINE test line**

In the Quiet Line, the noise power of the demodulated video signal is measured. Signal scanning occurs in the range 20  $\mu$ s to 60  $\mu$ s after the synchronization pulse. Suitable video signals are a black picture and a white picture. Due to the 200 kHz highpass filter in the test path, an unmodulated ramp signal is also suitable. All of the signals shown in the figure are suitable for measuring the noise power.

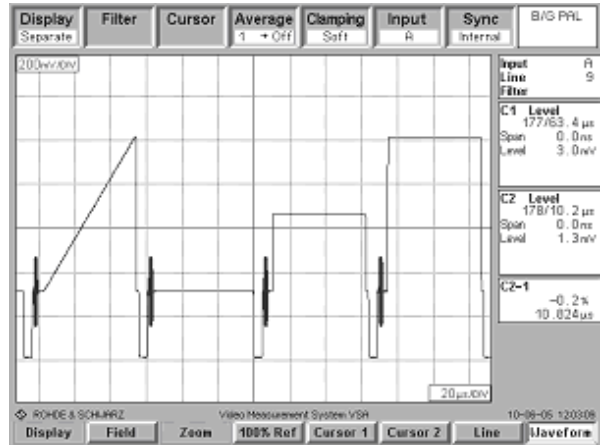

### Setting the Test Lines

You can set the test lines in the PARAMETER LIST and VISION MODULATION operating modes.

- Press the MEAS key until the F1 function key displays SELECT MEASURE.
- Press the SELECT MEASURE softkey.
- Using the cursor keys or the rotary knob, select the MEASUREMENT LIST or VISION MODULATION operating mode and confirm your choice with the ENTER key or the SELECT MEASURE softkey.

For the B, G, H, D, K, I, L and M/PAL standards:

- Press the SET TEST LINE softkey.

The R&S FSH3-TV opens the menu for setting the test lines.

- Using the rotary knob or the cursor keys, select the test line and confirm your choice with the ENTER key or the SET TEST LINE softkey.

The R&S FSH3-TV opens the entry field for setting the test line position.

- Using the rotary knob or the cursor keys, change the test line position or use the numeric keypad to enter a new position and confirm your choice with the ENTER key or the SET TEST LINE softkey.

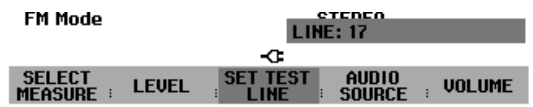
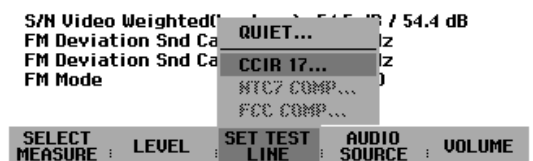

For the M/NTSC standard:

- Press the SET TEST LINE softkey.

The R&S FSH3-TV opens the menu for setting the test lines.

- Using the rotary knob or the cursor keys, select the test line and confirm your choice with the ENTER key or the SET TEST LINE softkey.

The R&S FSH3-TV opens the menu for selecting the field.

- Using the rotary knob or the cursor keys, select the field and confirm your choice with the ENTER key or the SET TEST LINE softkey.

The R&S FSH3-TV opens the entry field for setting the test line position.

- Using the rotary knob or the cursor keys, change the test line position or use the numeric keypad to enter a new position and confirm your choice with the ENTER key or the SET TEST LINE softkey.

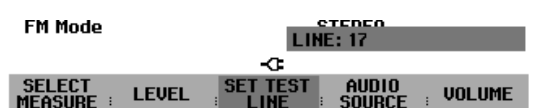
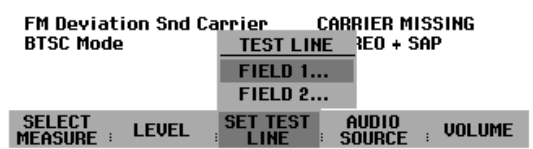
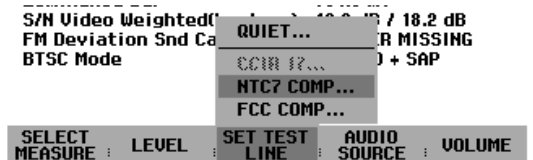

## Video Output

In the MEASUREMENT LIST and VIDEO SCOPE operating modes, the R&S FSH3-TV provides the demodulated video signal with a 75 Ohm source impedance on the instrument's BNC jack. The video output signal is clamped to the black level. The DC value of the black level is equal to 0 V.

*Note: The audio signals are not available in the CARRIER MEASUREMENTS, VISION MODULATION and HUM MEASUREMENT operating modes.*

The video amplitude is dependent on the modulation factor of the vision carrier and the selected standard.

Standard	Vision carrier modulation factor		Video amplitude
	Modulation depth	Residual carrier	
B, G, H	89 %	11 %	1 V
D, K, M/NTSC, M/PAL, N	87.5 %	12.5 %	1 V
I	80 %	20 %	1 V
L	87 %	3 %	1 V

### Switching on the video output:

- Press the SETUP key.
- Press the HARDWARE SETUP softkey.
- Using the rotary knob or the cursor keys, select CCVS OUT and confirm your choice with the ENTER key or the HARDWARE SETUP softkey.

## Audio Output

In the MEASUREMENT LIST and VIDEO SCOPE operating modes, the R&S FSH3-TV provides the decoded audio signals on the headphone output. You should select the audio source in the MEASUREMENT LIST operating mode. The source impedance is equal to 100 Ohm.

*Note: The audio signals are not available in the CARRIER MEASUREMENTS, VISION MODULATION and HUM MEASUREMENT operating modes.*

The audio signal selection is dependent on the standard which is set.

Audio standard	Menu selection	Explanation
FM 5.5 / FM 5.742 FM 6.5 / FM 6.742 FM 6.5 / FM 6.258 FM 4.5 / FM 4.724	AUTO 1 AUTO 2 STEREO SOUND 1 SOUND 2 MONO	<p><b>AUTO 1:</b> The decoding is performed depending on the transmitted FM mode. In two-sound mode, sound 1 is reproduced.</p> <p><b>AUTO 2:</b> The decoding is performed depending on the transmitted FM mode. In two-sound mode, sound 2 is reproduced.</p> <p><b>STEREO:</b> The audio signals are stereo-decoded regardless of the transmitted FM mode.</p> <p><b>SOUND 1:</b> The audio signal for the first sound carrier is reproduced regardless of the transmitted FM mode.</p> <p><b>SOUND 2:</b> The audio signal for the second sound carrier is reproduced regardless of the transmitted FM mode.</p> <p><b>MONO:</b> The audio signal for the first sound carrier is reproduced regardless of the transmitted FM mode.</p>
FM 5.5 MONO FM 6.5 MONO FM 4.5 MONO FM 6.0 MONO AM 6.5 MONO	MONO	You cannot make any selections in this default setting. Mono reproduction is always used.

Audio standard	Menu selection	Explanation
FM 5.5 / NICAM 5.85 FM 6.5 / NICAM 5.85 FM 6.0 / NICAM 6.552	AUTO 1 AUTO 2 NICAM SOUND 1 NICAM SOUND 2 NICAM MONO FM MONO	<p><b>AUTO 1:</b> The decoding is performed corresponding to the transmitted NICAM mode. In two-sound mode, sound 1 is reproduced. If no NICAM carrier is detected, FM mono sound is reproduced.</p> <p><b>AUTO 2:</b> The decoding is performed corresponding to the transmitted NICAM mode. In two-sound mode, sound 2 is reproduced. If no NICAM carrier is detected, FM mono sound is reproduced.</p> <p><b>NICAM SOUND 1:</b> The first NICAM sound is reproduced regardless of the transmitted NICAM mode.</p> <p><b>NICAM SOUND 2:</b> The second NICAM sound is reproduced regardless of the transmitted NICAM mode.</p> <p><b>NICAM MONO:</b> The first NICAM sound is reproduced regardless of the transmitted NICAM mode.</p> <p><b>FM MONO:</b> The audio signal of the FM sound carrier is reproduced regardless of the transmission mode.</p>
AM 6.5 / NICAM 5.85	AUTO 1 AUTO 2 NICAM SOUND 1 NICAM SOUND 2 AM MONO	<p><b>AUTO 1:</b> The decoding is performed corresponding to the transmitted NICAM mode. In two-sound mode, sound 1 is reproduced. If no NICAM carrier is detected, AM mono sound is reproduced.</p> <p><b>AUTO 2:</b> The decoding is performed corresponding to the transmitted NICAM mode. In two-sound mode, sound 2 is reproduced. If no NICAM carrier is detected, AM mono sound is reproduced.</p> <p><b>NICAM SOUND 1:</b> The first NICAM sound is reproduced regardless of the transmitted NICAM mode.</p> <p><b>NICAM SOUND 2:</b> The second NICAM sound is reproduced regardless of the transmitted NICAM mode.</p> <p><b>AM MONO:</b> The audio signal of the AM sound carrier is reproduced regardless of the transmission mode.</p>



Audio standard	Menu selection	Explanation
FM 4.5 BTSC FM 4.5 EIA-J	AUTO STEREO -> SAP AUTO SAP -> STEREO STEREO SAP MONO	<p><b>AUTO STEREO -&gt; SAP:</b> The decoding is dependent on the transmission mode. If both stereo sound and the second audio program (SAP) are transmitted, stereo sound has priority. If neither stereo nor SAP are transmitted, mono sound is reproduced.</p> <p><b>AUTO SAP -&gt; STEREO:</b> The decoding is dependent on the transmission mode. If both stereo sound and the second audio program (SAP) are transmitted, the second audio program has priority. If neither stereo nor SAP are transmitted, mono sound is reproduced.</p> <p><b>STEREO:</b> Stereo decoding is used regardless of the transmission mode.</p> <p><b>SAP:</b> The second audio program is reproduced regardless of the transmission mode.</p> <p><b>MONO:</b> Mono sound is reproduced regardless of the transmission mode.</p>

Standard	Modulation	Volume	Audio amplitude	
FM IRT-A2	FM 30 kHz, AF 500 Hz	0 dB	0 dBm	775 mV
FM BTSC	FM 25 kHz, AF 500 Hz	0 dB	0 dBm	775 mV
FM EIA-J	FM 25 kHz, AF 500 Hz	0 dB	0 dBm	775 mV
FM Korea	FM 30 kHz, AF 500 Hz	0 dB	0 dBm	775 mV
AM		0 dB	0 dBm	775 mV
NICAM		0 dB	0 dBm	775 mV

**Selecting the audio source:**

The audio source should be selected in the Measurement List operating mode. The possible settings are dependent on the selected TV standard. The figure shows the selection menu for the M/NTSC standard.

- Press the MEAS key until the F1 function key displays SELECT MEASURE.
- Press the SELECT MEASURE softkey.
- Using the cursor keys or the rotary knob, select the MEASUREMENT LIST operating mode and confirm your choice with the ENTER key or the SELECT MEASURE softkey.
- Press the AUDIO SOURCE softkey.
- Using the rotary knob or the cursor keys, select the audio source you want and confirm your choice with the ENTER key or the AUDIO SOURCE softkey.

```

ANALOG TV RECEIVER
TV Std. - Group Delay      M/NTSC - FCC
Sound Standard            FM 4.5 BTSC
Vision Carrier Frequency  471.25 MHz
Channel                    --
Reference Level            -20 dBm   (1 dB)
-----
Vision Carrier Level      -21.2 dBm
Carrier Frequency Offset  0 kHz
Vision Detector            LOCKED
Sync Separator            H+V SYNC
Luminance Bar             703.0 mV
S/N Video Weighted(bar/nom)
FM Deviation Snd Carrier
BTSC Mode
                                <G>
SELECT MEASURE : LEVEL : SET TEST : AUDIO SOURCE : VOLUME
                    LINE :
    
```

**Setting the volume:**

The audio source should be selected in the Measurement List operating mode.

- Press the MEAS key until the F1 function key displays SELECT MEASURE.
- Press the SELECT MEASURE softkey.
- Using the cursor keys or the rotary knob, select the MEASUREMENT LIST operating mode and confirm your choice with the ENTER key or the SELECT MEASURE softkey.

The R&S FSH3-TV opens the entry field for setting the volume.

- Using the rotary knob or the cursor keys, change the volume or use the numeric keypad to enter a new volume and confirm your choice with the ENTER key or the VOLUME softkey.

The stepsize when using the cursor keys is equal to 5 dB. When using the rotary knob, it is equal to 0.5 dB. You can use the numeric keypad to set the volume with the resolution of 0.125 dB.

**Measurement Parameter List**

The measurement parameter list provides an overview of the important instrument settings, the received signal status and the quality of the received analog TV signal.

**Screen Layout**

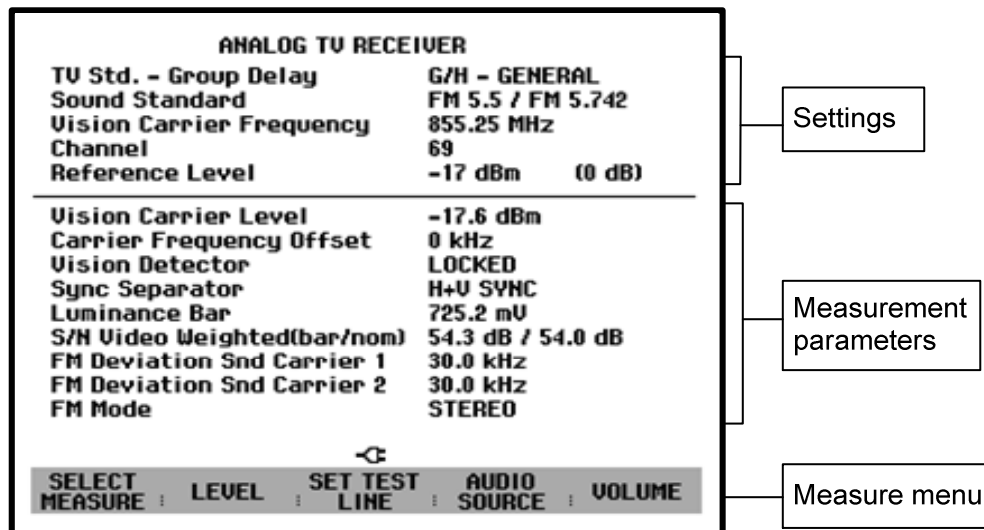

The instrument settings that are shown are dependent on the selected standard.

<b>Instrument settings</b>	<b>Explanation</b>
<b>TV std. – group delay</b>	The selected analog TV standard and the group delay equalization of the video signal are displayed. You can select the standard in the SETUP – LOCAL SETTINGS – ANALOG TV menu.
<b>Sound standard</b>	This sound transmission standard that you have selected is displayed. You can select this sound standard along with the setting for the TV standard and the group delay equalization in the SETUP – LOCAL SETTINGS – ANALOG TV menu.
<b>Vision carrier frequency</b>	The vision carrier frequency you have selected is displayed.
<b>Channel</b>	The channel number and information about the selected channel are displayed. Information is displayed also when you are setting the vision carrier frequency, but only if the setting for the vision carrier frequency matches a corresponding vision carrier frequency of a channel in the selected channel table. A frequency offset of up to 40 kHz is tolerated.
<b>Reference level</b>	<p>The reference level which is set is displayed in the measurement screen.</p> <p>To help you to make the optimum reference level setting, the distance to the maximum demodulator level is displayed in parentheses after the currently set value.</p> <p>If a value of "0 dB" is displayed, then the demodulator has the optimum drive setting.</p> <p>If, for example, a value of "7 dB" is displayed, then you need to reduce the reference level by 7 dB.</p> <p>If TOO LOW is displayed, then the demodulator is overdriven. In this case, the reference level must be increased.</p> <p>If TOO HIGH is displayed, then the demodulator is underdriven or no analog TV signal is being received on the set receive frequency. You need to reduce the reference level.</p> <p>To simplify operation and to avoid incorrect measurements, the R&amp;S R&amp;S FSH3-TV is equipped with an automatic routine (LEVEL ADJUST) for setting the optimum reference level. In the Measurement List operating mode, the setting criterion for the LEVEL ADJUST function is the signal-to-noise ratio for the video signal.</p>

The measurement parameters that are shown are dependent on the selected standard.

Measurement parameter	Explanation
<b>Vision carrier power</b>	The vision carrier power for the received useful signal is displayed using the selected unit. The unit is set in the MEAS menu.
<b>Carrier frequency offset</b>	The carrier frequency offset represents the frequency offset between the received vision carrier and the vision carrier frequency setting. The R&S FSH3-TV demodulates analog TV signals with a carrier frequency offset of up to 700 kHz.  <i>Note:</i> <i>The frequency offset is output in the Measurement List operating mode only with a resolution of 10 kHz. For accurate measurement of the vision carrier frequency, please use the CARRIER MEASUREMENTS operating mode.</i>
<b>Vision detector</b>	The status of the video demodulator is displayed. <b>LOCKED:</b> The PLL of the vision demodulator is locked. <b>UNLOCKED:</b> The PLL of the vision demodulator is not locked.
<b>Sync separator</b>	The status of the amplitude filter is displayed. <b>H+V SYNC:</b> The receiver is triggered by the horizontal and vertical sync pulses of the received signal. <b>NO VERTICAL SYNC:</b> The receiver is triggered by the horizontal sync pulses of the received signal. Triggering in response to the vertical sync pulses is not possible. The video parameters Luminance Bar and S/N Video weighted (nom) are measured in each line. This means that the measurement results are correct only under certain conditions. They are marked with an asterisks "***". <b>NO HORIZONTAL SYNC:</b> The receiver is synchronized to neither the horizontal nor the vertical sync pulses of the received signal. This means that it is not possible to measure the video parameters.  <i>Note:</i> <i>You can correctly measure the video parameters which are measured in the test lines only if the receiver is synchronized to the horizontal and vertical sync pulses of the received signal.</i>

Measurement parameter	Explanation
<b>Luminance bar</b>	<p>Luminance bar (black-white offset) is the voltage difference between the white level and the black level of the demodulated video signal. The R&amp;S FSH3-TV performs the measurement in the test line CCIR 17 for the B, G, H, D, K, I, N and L standards. For the M/NTSC and M/PAL standards, the R&amp;S FSH3-TV measures the luminance bar in the test line NTC7 COMP or FCC COMP depending on the setting in the SET TEST LINE menu. The measurement result is output in mV. For the M/NTSC and M/PAL standards, the choice is either IRE or mV.</p> <p>The test line setting must be matched to the received signal. Settings are made in the SET TEST LINE menu.</p> <p>The measurement will be performed correctly only if the receiver is triggered to the horizontal and vertical sync pulses of the received signal. If the vertical sync pulse is missing, the measurement is made in each line and the measurement result is marked with an asterisks "**".</p>
<b>S/N video weighted (bar)</b> <b>S/N video weighted (nom)</b>	<p>The R&amp;S FSH3-TV measures the signal-to-noise ratio of the demodulated video signal. The signal quantity for the measurement parameter <b>S/N Video weighted (nom)</b> is the nominal value of the black-white offset (luminance bar). The signal quantity for the measurement parameter <b>S/N Video weighted (bar)</b> is the luminance bar measurement result.</p> <p>The noise power of the demodulated video signal is detected in the QUIET LINE. The noise signal is weighted based on CCIR 567 and the RMS value is formed.</p> <p>The quiet line can be a black line, a white line or an unmodulated ramp. The line number of the quiet line must be matched to the received signal. Settings are made in the SET TEST LINE menu.</p> <p>The <b>S/N Video weighted (bar)</b> value will be measured correctly only if the receiver is synchronized to the horizontal and vertical sync pulses of the received signal.</p> <p>In order to compute the <b>S/N Video weighted (nom)</b> value, the noise power is measured in each line if the vertical sync pulse is missing. The measurement result is marked with an asterisks "**".</p>
<b>AM sound modulation</b> (only for L standard)	The modulation factor of the AM sound carrier is displayed. If the sound carrier is missing, <b>MISSING</b> is displayed.
<b>FM sound deviation</b> (not for L standard)	The FM deviation of the FM sound carrier is displayed. If the sound carrier is missing, <b>MISSING</b> is displayed.
<b>FM sound deviation 1</b> (not for L standard)	The FM deviation of the first FM sound carrier is displayed. If the first sound carrier is missing, <b>MISSING</b> is displayed.
<b>FM sound deviation 2</b> (not for L standard)	The FM deviation of the second FM sound carrier is displayed. If the second sound carrier is missing, <b>MISSING</b> is displayed.
<b>NICAM carrier</b> (only for standards with a NICAM carrier)	An indication is made as to whether a NICAM carrier is detected. If a NICAM carrier is detected, <b>PRESENT</b> is displayed. If no NICAM carrier is detected, <b>MISSING</b> is displayed.

Measurement parameter	Explanation
<b>FM mode</b> (only for FM-2 sound transmission standards)	The sound transmission mode of the FM sound carriers is displayed. <b>MONO</b> Mono transmission <b>DUAL</b> Dual-channel sound transmission <b>STEREO</b> Stereo transmission
<b>BTSC mode</b> (only for the BTSC or EIA-J standards)	The sound transmission mode of the BTSC sound carrier is displayed. <b>MONO</b> Mono transmission <b>STEREO</b> Stereo transmission <b>SAP</b> Second audio program available <b>STEREO+SAP</b> Stereo transmission and second audio program available
<b>NICAM mode</b> (only for standards with a NICAM carrier)	The transmission mode of the NICAM carrier is displayed. <b>MONO</b> Mono transmission <b>DUAL</b> Dual-channel sound transmission <b>STEREO</b> Stereo transmission <b>MONO+DATA</b> Mono sound and data transmission <b>DATA ONLY</b> Data transmission, no audio signals available
<b>NICAM BER</b> (only for standards with a NICAM carrier)	The bit error ratio for the received NICAM carrier is displayed.  <i>Note: The parity is checked in this computation. It is not possible to detect multiple errors within a byte.</i>

## Switching on the Measurement Parameter List

Switching on the measurement parameter list if the analog TV receiver is already activated:

- Press the MEAS key until the F1 function key displays SELECT MEASURE.
- Press the SELECT MEASURE softkey.
- Using the rotary knob or the cursor keys, select MEASUREMENT LIST and confirm your choice with the ENTER key or the SELECT MEASURE softkey.

Switching on the measurement parameter list if another measurement mode besides analog TV receiver is already activated:

- Press the MEAS key until the F1 function key displays MEASURE.
- Using the rotary knob or the cursor keys, select ANALOG TV RECEIVER and confirm your choice with the ENTER key or the MEASURE softkey.
- Using the rotary knob or the cursor keys, select MEASUREMENT LIST and confirm your choice with the ENTER key or the SELECT MEASURE softkey.

The measurement parameter list should appear in the display. The function keys for the menus should be switched.

## **Level Adjust**

To simplify operation and to avoid incorrect measurements, the R&S FSH3-TV is equipped with an automatic routine (LEVEL ADJUST) for setting the optimum reference level. In the Measurement List operating mode, the setting criterion for the LEVEL ADJUST function is the signal-to-noise ratio for the video signal.

- Press the MEAS key until the F1 function key displays SELECT MEASURE.
- Press the LEVEL softkey.
- Start the routine with the ENTER key or the LEVEL softkey.

While the R&S FSH3-TV is looking for the optimum reference level, it will show a corresponding message on the display.

## Video Oscilloscope

In the VIDEO SCOPE operating mode, the R&S FSH3-TV displays the time-domain version of the demodulated video signal.

### Screen Layout

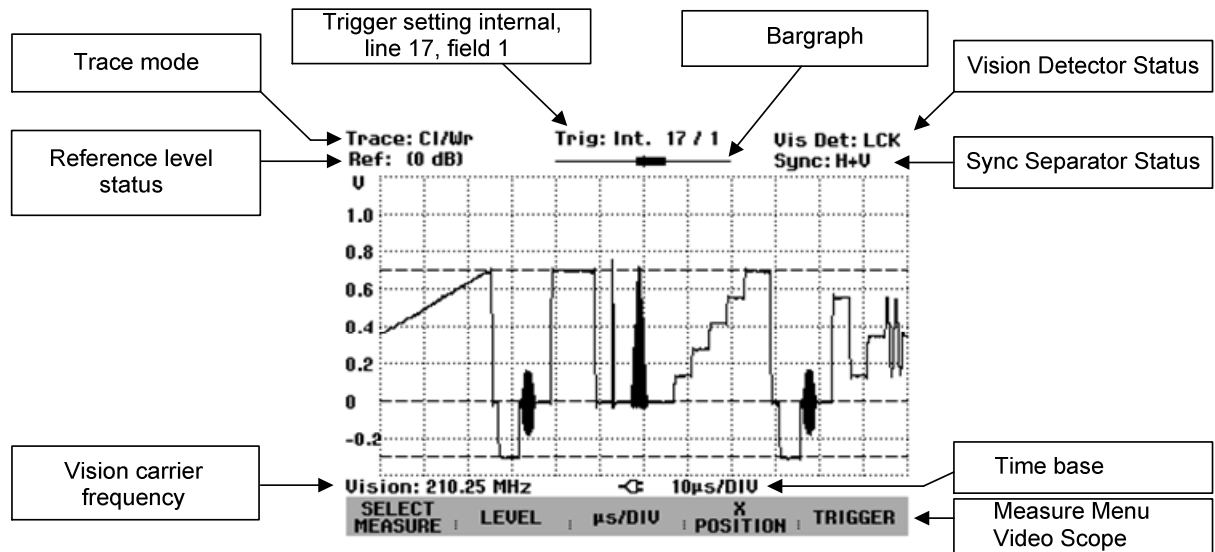

### Switching on the Video Oscilloscope

Switching on the video oscilloscope if the analog TV receiver is already activated:

- Press the MEAS key until the F1 function key displays SELECT MEASURE.
- Press the SELECT MEASURE softkey.
- Using the rotary knob or the cursor keys, select VIDEO SCOPE and confirm your choice with the ENTER key or the SELECT MEASURE softkey.

The measurement screen for the video oscilloscope should appear in the display. The function keys for the menus should be switched.

Switching on the video oscilloscope if another measurement mode besides analog TV receiver is already activated:

- Press the MEAS key until the F1 function key displays MEASURE.
- Using the rotary knob or the cursor keys, select ANALOG TV RECEIVER and confirm your choice with the ENTER key or the MEASURE softkey.
- Using the rotary knob or the cursor keys, select VIDEO SCOPE and confirm your choice with the ENTER key or the SELECT MEASURE softkey.

The measurement screen for the video oscilloscope should appear in the display. The function keys for the menus should be switched.



### Level Adjust

To simplify operation and to avoid incorrect measurements, the R&S FSH3-TV is equipped with an automatic routine (LEVEL ADJUST) for setting the optimum reference level. In the Video Scope operating mode, the setting criterion for the LEVEL ADJUST function is the signal-to-noise ratio of the video signal.

- Press the MEAS key until the F1 function key displays SELECT MEASURE.
- Press the LEVEL softkey.
- Start the routine with the ENTER key or the LEVEL softkey.

While the R&S FSH3-TV is looking for the optimum reference level, it will show a corresponding message on the display.

### Setting the Time Basis

You can set the time basis between 1  $\mu$ s / division and 50  $\mu$ s / division.

- Press the MEAS key until the F1 function key displays SELECT MEASURE.
- Press the  $\mu$ s/DIV softkey.

The R&S FSH3-TV opens the menu for setting the time basis.

- Using the rotary knob or the cursor keys, select the test line and confirm your choice with the ENTER key or the  $\mu$ s/DIV softkey.

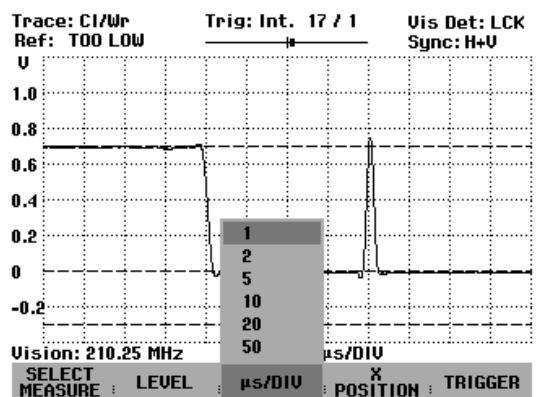

### Setting the Horizontal Position

The horizontal position setting allows you to offset the video signal in time. In the default setting, a horizontal offset of 32  $\mu$ s is set. In this setting, the trigger line is shown in the center of the display.

The possible offset range is dependent on the time basis which is set. To help you to make this setting, the trigger line and a bar graph are inserted at the top center of the display to show the currently displayed time range and the possible offset.

- Press the MEAS key until the F1 function key displays SELECT MEASURE.
- Press the X POSITION softkey.

The R&S FSH3-TV opens the entry field for setting the horizontal offset.

- Using the rotary knob or the cursor keys, set the horizontal offset or enter it on the keypad and confirm your choice with the unit key or the X POSITION softkey.

## Triggering in the Video Scope Operating Mode

Triggering in the Video Scope operating modes is based on the received TV signal.

- LINE... Triggering is based on the set video line. If the amplitude filter does not detect any vertical sync pulses, the R&S FSH3-TV triggers on each line. If it is also not possible to synchronize to the horizontal sync pulses, the sweep is initiated as soon as the previous one has terminated. The current synchronization status is shown at the top right of the display. In the default setting, triggering is set to line 17 of the first field.
- FIELD... The field can be selected.

The R&S FSH3-TV shows the current trigger setting at the top center of the screen. For example, "Trig: Line 17/1" means that triggering is set for video line 17 of the first field of the demodulated video signal.

### Operating sequence:

You can set the trigger line in the sweep menu and in the measurement menu.

➤ Press the SWEEP key.

or

➤ Press the MEAS key until the F1 function key displays SELECT MEASURE.

➤ Press the TRIGGER softkey.

The R&S FSH3-TV opens the menu for making the trigger setting.

➤ Using the rotary knob or the cursor keys, select the LINE... menu item and confirm your choice with the ENTER key or the TRIGGER softkey.

The R&S FSH3-TV opens the entry field for setting the video trigger line.

➤ Using the rotary knob or the cursor keys, change the trigger line or use the numeric keypad to enter the trigger line and confirm your choice with the ENTER key or the TRIGGER softkey.

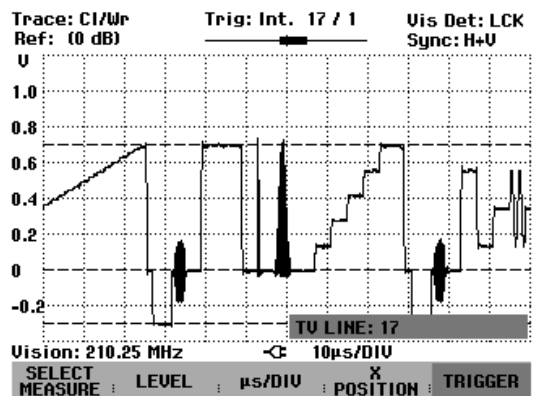
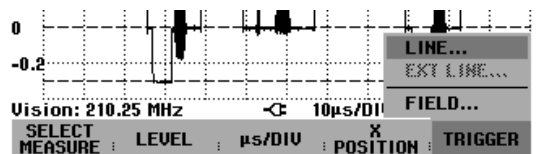
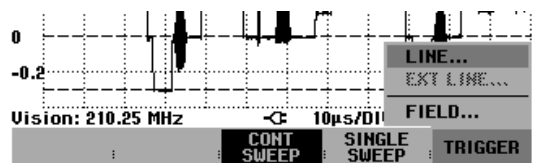

**Selecting the field:**

The R&S FSH3-TV makes it easy to switch over to the corresponding video line of the other field.

➤ Press the SWEEP key.

or

➤ Press the MEAS key until the F1 function key displays SELECT MEASURE.

➤ Press the TRIGGER softkey.

➤ Using the rotary knob or the cursor keys, select FIELD from the menu and confirm your choice with the ENTER key or the TRIGGER softkey.

➤ Using the rotary knob or the cursor keys, select the field you want and confirm your choice with the ENTER key or the TRIGGER softkey.

### Markers in the Video Scope Operating Mode

The R&S FSH3-TV has a marker and a delta marker to make it easier to read off trace values. The markers cannot leave the trace and indicate the time and amplitude of the point they are positioned on. The time position of the marker is referred to the front edge of the sync pulse of the trigger line and is indicated with a vertical line over the entire measurement diagram. The vertical line is indicated with the **M** marker symbol. The amplitude is referred to the black level. The amplitude unit is determined by the unit which is set. You can control this in the LEVEL menu.

The position of the delta marker is indicated by a dashed line to distinguish it from the other marker. The amplitude and the time of the delta marker are always relative to the main marker. The vertical line is indicated with the **D** delta marker symbol.

The numerical time and amplitude readouts are displayed in the top left-hand corner of the screen.

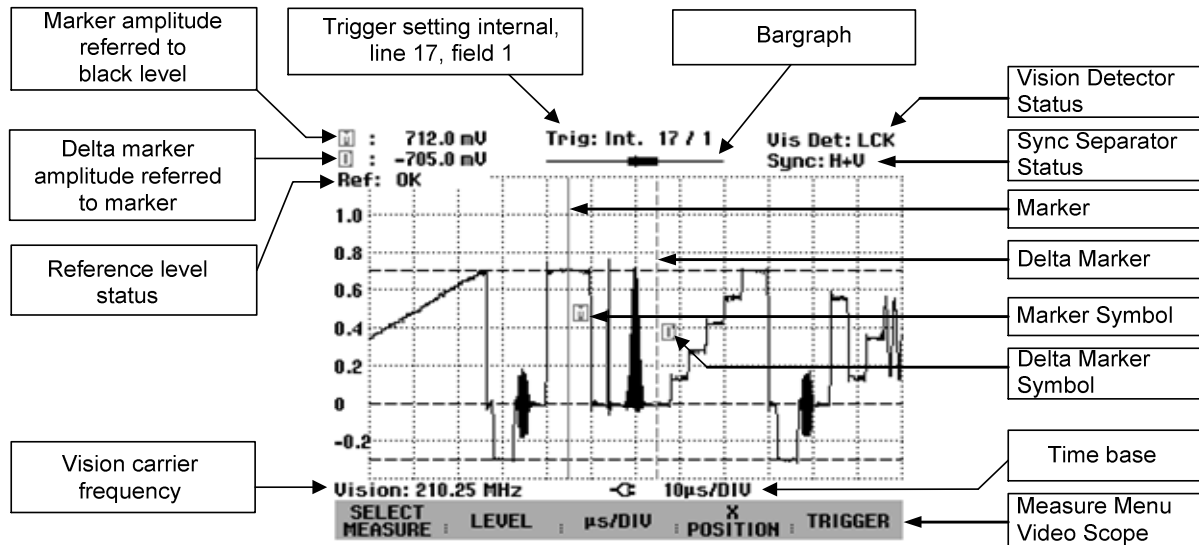

#### Interpretation of the marker:

- Press the MARKER key.

The R&S FSH3-TV opens the Marker menu. If, as yet, no marker has been activated, the main marker (MARKER) is turned on automatically and placed on the smallest amplitude level on the trace. The entry box for the marker position opens.

The following actions can now be performed:

- You can change the marker position with the rotary knob or the cursor keys.
- You can enter a marker position with the keypad and complete your entry by pressing a unit key.

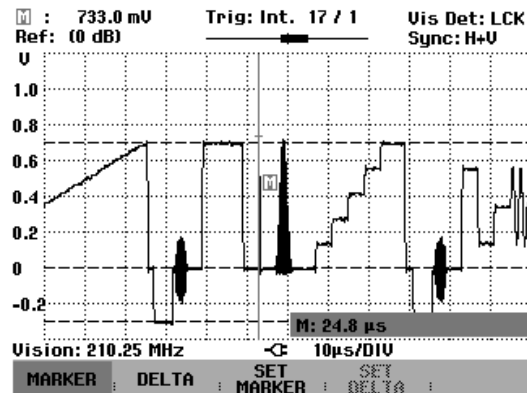

**Operating sequence for the delta marker:**

- Press the MARKER key.
- Press the DELTA softkey.

The R&S FSH3-TV turns on the delta marker and places it on the highest amplitude level on the trace. Simultaneously, the entry box is opened for the time offset between the delta marker and the main marker.

The following actions can now be performed:

- You can change the delta marker position with the rotary knob or the cursor keys.
- You can enter a delta marker position with the keypad and complete your entry by pressing a unit key.

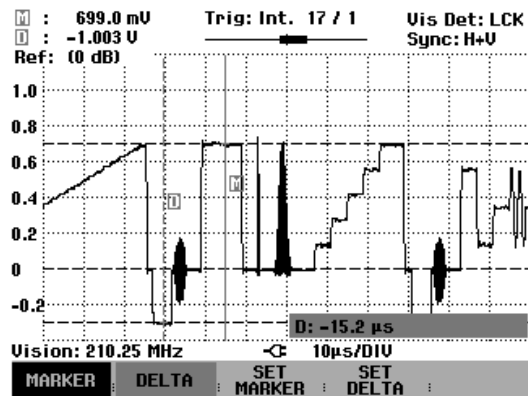

**Automatic Positioning of the Marker**

The R&S FSH3-TV has functions that make setting markers easier or allow instrument settings to be made on the basis of the current marker position:

- CENTER = MARKER      When you call this function, the R&S FSH3-TV sets the center position equal to the current position of the marker. This function is particularly useful if you want to investigate a signal more closely using a smaller span. This is accomplished by first placing the signal in the center of the frequency span and then reducing the span.
- PEAK      This function places the marker on the highest value in the trace.
- MINIMUM      This function places the marker on the lowest value in the trace. If the trace is displayed in Clear/Write mode, this function places the marker on the smallest value based on the maximum values of the trace.

**Operating sequence:**

- Press the MARKER key.
- Press the SET MARKER softkey.
- Select the desired function in the submenu using the rotary knob or the cursor keys.
- Confirm your choice with the ENTER key or the SET MARKER softkey.

The R&S FSH3-TV performs the desired action.

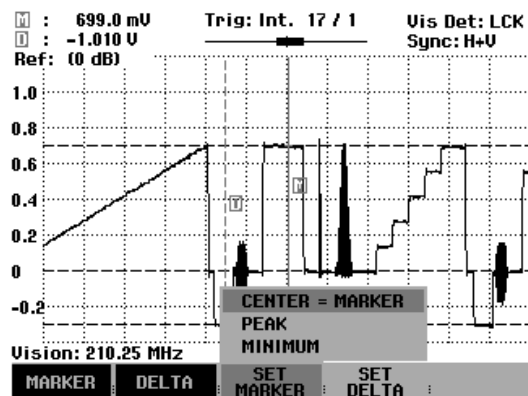

## Unit for the Delta Marker

The R&S FSH3-TV outputs the amplitude result for the delta marker in either absolute or relative terms. In the ABSOLUTE setting, the result is output in either mV or IRE depending on the current setting. If the current setting is RELATIVE, the measured value is output with respect to a reference measurement as a %. Before you can display the measured value as a %, it is necessary to perform the 100% reference measurement. The reference measurement sets the amplitude difference between the marker and delta marker to 100%. It is not possible to set the relative unit until you have performed the reference measurement.

### Operating sequence:

Set the relative unit:

- Press the MARKER key.

The main marker is activated.

- Use the rotary knob, the cursor keys or a numerical entry to set the desired position.
- Press the DELTA softkey.
- Use the rotary knob, the cursor keys or a numerical entry to set the desired position.
- Press the SET DELTA softkey.
- Select 100 % REF with the rotary knob or the cursor keys.
- Confirm your choice with the ENTER key or the SET DELTA softkey.

The R&S FSH3-TV sets the current measured value for the delta marker to 100%.

- Press the SET DELTA softkey.
- Select RELATIVE with the rotary knob or the cursor keys.
- Confirm your choice with the ENTER key or the SET DELTA softkey.

The R&S FSH3-TV displays the delta marker value with respect to the previously measured reference value as a %.

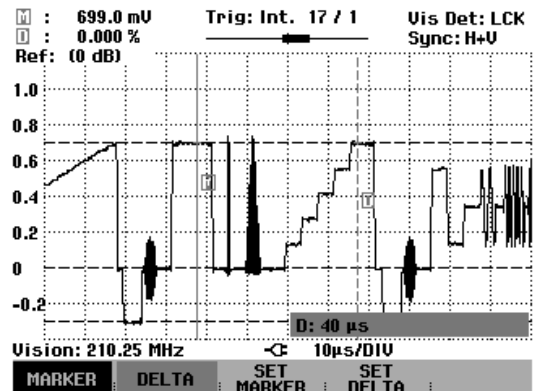
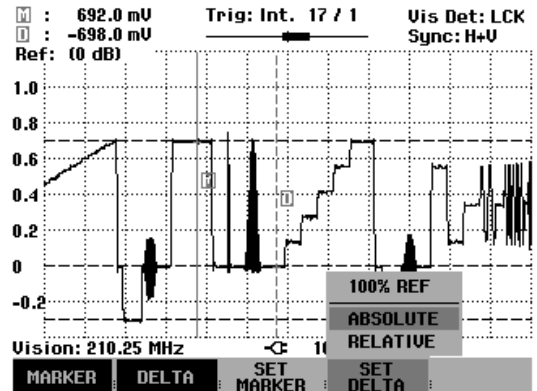

### Trace Modes

A variety of display modes can be selected for the trace:

- CLEAR/WRITE                      The R&S FSH3-TV clears the old trace during a new sweep. This is the default setting.
- AVERAGE                         The R&S FSH3-TV computes the average value based on consecutive measured traces. In the default setting, averaging is on a pixel-by-pixel basis and is sliding over the ten previous traces. Alternatively, you can set the number for the averaging from 2 to 999. This reduces the effects of noise, for example, but has no effect on video signals.
- MAX HOLD                         The trace indicates the maximum value that has been measured up to that point in time. The R&S FSH3-TV interrupts the Max Hold mode only if another setting is selected and the trace pixels from the new setting cannot be compared with the trace pixels from the previous setting – for example if the trigger setting is changed.
- MIN HOLD                         The trace indicates the minimum value that has been measured up to that point in time. The R&S FSH3-TV interrupts the Min Hold mode only if another setting is selected and the trace pixels from the new setting cannot be compared with the trace pixels from the previous setting.
- VIEW                                The R&S FSH3-TV freezes the currently displayed trace. The measurement is aborted. This, for instance, allows subsequent evaluation of spectra with the aid of the marker.

### Operating sequence:

- Press the TRACE key.
- Press the TRACE MODE softkey.

The R&S FSH3-TV opens the submenu with trace mode settings.

- Use the cursor keys or the rotary knob to select the desired Trace Mode and confirm your selection with the ENTER key or the TRACE MODE softkey.

The "Trace:" indicator at the top left of the display shows the current setting.

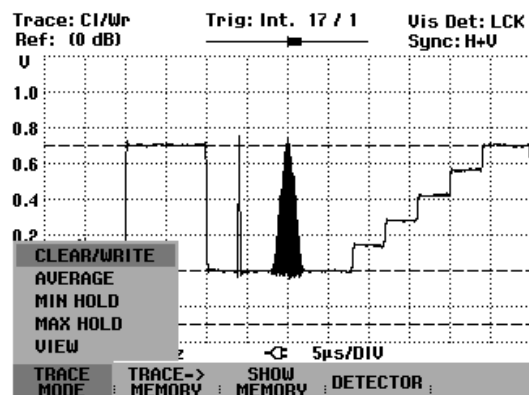

If TRACE MODE AVERAGE is selected, the AVG COUNT entry field opens and displays the set number of averagings.

The following actions can be performed:

- Confirm the displayed number of averagings with the TRACE softkey or the ENTER key.
- Using the numeric keypad, enter a new number between 2 and 999 for the number of averagings and confirm your entry with the TRACE softkey or the ENTER key.
- Change the number of averagings by using the rotary knob and confirm your entry with the TRACE softkey or the ENTER key.

The R&S FSH3-TV averages the pixels of the trace over the set number of averagings.

If the sweep is continuous, the instrument then performs a sliding averaging. In SINGLE SWEEP mode, it performs exactly those sweeps defined with AVG COUNT and averages the traces. It then stops the sweep and displays the averaged trace.

In the VIEW trace mode, the settings used for measuring the trace are displayed. This ensures that the measurement conditions are clearly specified in result documentation. In the status display (STATUS key), an indication is made in parentheses that the view mode is currently selected, e.g. Trace Mode: Maximum Hold (View).

## **Trace Memory**

The R&S FSH3-TV can transfer a trace to the trace memory and also display the current trace and the trace in trace memory for comparison. The saved trace is always displayed in white to distinguish it from the current trace.

### **Operating sequence:**

- Press the TRACE key.
- Press the TRACE -> MEMORY softkey.

The R&S FSH3-TV transfers the currently displayed trace to the trace memory.

- Press the SHOW MEMORY softkey.

The R&S FSH3-TV displays the saved trace in white. The SHOW MEMORY softkey is highlighted in green to indicate that the trace in the trace memory is being displayed.

- To remove the saved trace from the screen, press the SHOW MEMORY softkey again.

*Note: The R&S FSH3-TV saves the memory trace as a bit map in the screen memory. This means that it does not adapt the memory trace to the modified amplitude or time range.*



## Measuring the Vision Carrier Modulation

In the VISION MODULATION operating mode, the R&S FSH3-TV measures the modulation depth, the residual carrier and the vision carrier peak power. In the default setting, the measurement is made in the set test line. The marker positions are preset to the set test line for scanning the white and sync levels. By modifying the test line and offsetting the markers, it is also possible to make the measurement with other test lines.

*Note:* The video output signal is not available in the VISION MODULATION operating mode.

### Definitions of the Measurement Parameters

- Residual carrier for negative modulation of the vision carrier (all standards except for L standard):

$$\text{Residual picture carrier} = \frac{\text{white level}}{\text{sync level}} \cdot 100\% = \frac{\text{WHITE MARKER}}{\text{SYNC MARKER}} \cdot 100\%$$

- Residual carrier for positive modulation of the vision carrier (L standard):

$$\text{Residual picture carrier} = \frac{\text{sync level}}{\text{white level}} \cdot 100\% = \frac{\text{SYNC MARKER}}{\text{WHITE MARKER}} \cdot 100\%$$

- Modulation depth of the vision carrier:

$$\text{Modulation depth} = 100\% - \text{residual picture carrier}$$

- Vision carrier peak power:

The vision carrier power is the maximum power or the maximum level of the current sweep.

### Screen Layout

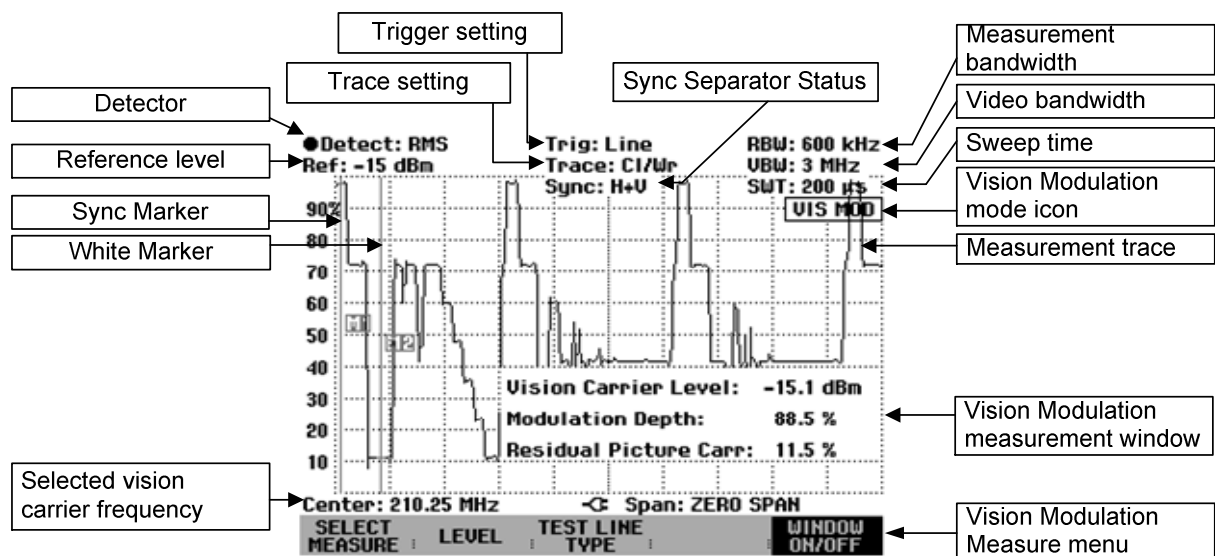

## Switching on Vision Modulation Operating Mode

Switching on the Vision Modulation operating mode if the analog TV receiver is already activated:

- Press the MEAS key until the F1 function key displays SELECT MEASURE.
- Press the SELECT MEASURE softkey.
- Using the rotary knob or the cursor keys, select VISION MODULATION and confirm your choice with the ENTER key or the SELECT MEASURE softkey.

The Vision Modulation measurement screen should appear in the display. The function keys for the menus should be switched. When the Vision Modulation operating mode is launched, the instrument settings are set to their defaults.

Switching on the Vision Modulation operating mode if another measurement mode besides analog TV receiver is already activated:

- Press the MEAS key until the F1 function key displays MEASURE.
- Using the rotary knob or the cursor keys, select ANALOG TV RECEIVER and confirm your choice with the ENTER key or the MEASURE softkey.
- Using the rotary knob or the cursor keys, select VISION MODULATION and confirm your choice with the ENTER key or the SELECT MEASURE softkey.

The Vision Modulation measurement screen should appear in the display. The function keys for the menus should be switched. When the Vision Modulation operating mode is launched, the instrument settings are set to their defaults.

## Level Adjust

To simplify operation and to avoid incorrect measurements, the R&S FSH3-TV is equipped with an automatic routine (LEVEL ADJUST) for setting the optimum reference level. In the Vision Modulation operating mode, the setting criterion for the LEVEL ADJUST function is the vision carrier level.

- Press the MEAS key until the F1 function key displays SELECT MEASURE.
- Press the LEVEL softkey.
- Start the routine with the ENTER key or the LEVEL softkey.

While the R&S FSH3-TV is looking for the optimum reference level, it will show a corresponding message on the display.

## Setting the Unit for the Vision Carrier Power

The measured peak vision carrier power can be displayed in either dBm, dBmV or dB $\mu$ V.

- Press the MEAS key.
- Press the LEVEL softkey.
- Using the rotary knob or the cursor keys, select the unit you want and confirm your choice with the ENTER key or the LEVEL softkey.

## Displaying the Measurement Parameters





In the Vision Modulation operating mode, the R&S FSH3-TV inserts the modulation parameters at the bottom of the measurement diagram. This can partially obscure the trace. If this is a problem, you can hide the indicators.

- Press the MEAS key until the F1 function key displays SELECT MEASURE.
- Press the WINDOW ON/OFF softkey.

The R&S FSH3-TV hides the measured value window. Press the WINDOW ON/OFF softkey again to redisplay the measured value window. If the softkey is highlighted in green, the display is on.

## Triggering in Vision Modulation Operating Mode

Triggering can be set to the received TV signal or to an external signal which is applied to the multi-function BNC jack.

- LINE... Triggering is based on the set video line in the demodulated video signal. This is the default setting. The trigger is preset to line 17. If the amplitude filter does not detect any vertical sync pulses, the R&S FSH3-TV triggers on each line. If neither vertical nor horizontal sync pulses are detected, the R&S FSH3-TV begins a new sweep as soon as the previous one is completed.
- VIDEO... A sweep starts when the video voltage exceeds a settable value. If the trigger setting VIDEO... was selected, you must enter the trigger level. The trigger level is expressed as a percentage (%) of the reference level. 100% means that the trigger level equals the reference level, 50% that the trigger level is in the middle of the Y axis on the measurement diagram (default setting). The R&S FSH3-TV shows the position of the video trigger level using a ">" on the level axis.
- EXT LINE... Triggering is based on the set video line of the video signal which is applied to the multi-function BNC jack. If the amplitude filter does not detect any vertical sync pulses, the R&S FSH3-TV triggers on each line. If neither vertical nor horizontal sync pulses are detected, the R&S FSH3-TV begins a new sweep as soon as the previous one is completed. For external triggering, the multi-function BNC jack must be set in the SETUP – HARDWARE SETUP menu to EXT TRIG. The video amplitude must range between 0.5 V and 2.0 V.
- EXTERN  and EXTERN  The sweep is started on the rising edge () or on the falling edge () of an external trigger signal. The external trigger signal is fed in via the multi-function BNC jack. The switching threshold is 1.4 V, i.e. a TTL signal level. In the SETUP / HARDWARE SETUP menu, you must set EXT TRIG.
- FIELD... In case of TV line triggering LINE... and EXT LINE..., you can select the field.
- DELAY... You can set a triggering delay. In this way, time differences between the trigger event and the measurement can be allowed for.

The R&S FSH3-TV shows the current trigger setting at the top center of the screen. For example, "Trig: Int Line 17/1" means that triggering is set for video line 17 of the first field of the internally demodulated video signal.

#### Operating sequence:

- Press the SWEEP key.
- Press the TRIGGER softkey.

The R&S FSH3-TV opens the menu for selecting the trigger.

- Use the cursor keys or the rotary knob to select the desired trigger and accept the input with the ENTER key or the TRIGGER softkey.

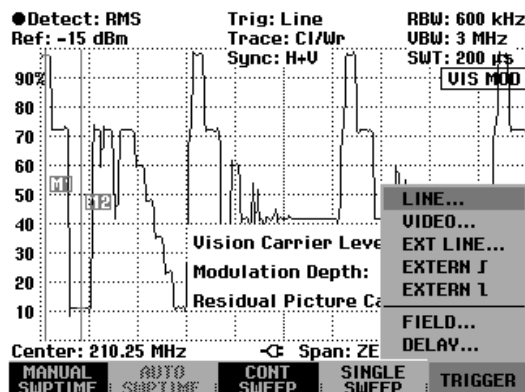

#### Triggering on a video line of the demodulated TV signal:

- Press the SWEEP key.
- Press the TRIGGER softkey.
- Using the rotary knob or the cursor keys, select the LINE... menu item and confirm your choice with the ENTER key or the TRIGGER softkey.

The R&S FSH3-TV opens the entry field for setting the video trigger line.

- Using the rotary knob or the cursor keys, change the trigger line or use the numeric keypad to enter the trigger line and confirm your choice with the ENTER key or the TRIGGER softkey.

#### Selecting the field:

When triggering on a TV line, the R&S FSH3-TV allows easy switching to the corresponding video line of the other field.

- Press the SWEEP key.
- Press the TRIGGER softkey.
- Using the rotary knob or the cursor keys, change the FIELD menu item or use the keypad and confirm your choice with the ENTER key or the TRIGGER softkey.

**Triggering on the amplitude of the measurement trace:**

If the trigger setting VIDEO... was selected, you must enter the trigger level. The trigger level is expressed as a percentage (%) of the reference level. 100% means that the trigger level equals the reference level, 50% that the trigger level is in the middle of the Y axis on the measurement diagram (default setting). The R&S FSH3-TV shows the position of the video trigger level using a ">" on the level axis.

- Use the cursor keys or the rotary knob to change the video trigger threshold (0 – 100 %).

The trigger threshold will be changed immediately after your input.

or

- Confirm the entry of the trigger threshold with the ENTER key or the TRIGGER softkey.

The R&S FSH3-TV closes the entry field.

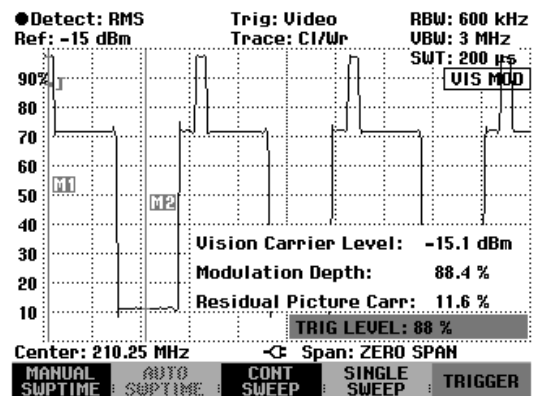

**Triggering on an external video signal or composite sync signal:**

- Press the SETUP key.
- Press the HARDWARE SETUP softkey.
- Using the cursor keys or the rotary knob, select EXT TRIG from the menu and confirm your choice with the ENTER key or the HARDWARE SETUP softkey.
- Press the SWEEP key.
- Press the TRIGGER softkey.
- Using the rotary knob or the cursor keys, select the EXT LINE... menu item and confirm your choice with the ENTER key or the TRIGGER softkey.

The R&S FSH3-TV opens the entry field for setting the video trigger line.

- Using the rotary knob or the cursor keys, change the trigger line or use the numeric keypad to enter the trigger line and confirm your choice with the ENTER key or the TRIGGER softkey.

**Triggering on an external signal with TTL levels:**

- Press the SETUP key.
- Press the HARDWARE SETUP softkey.
- Using the cursor keys or the rotary knob, select EXT TRIG from the menu and confirm your choice with the ENTER key or the HARDWARE SETUP softkey.
- Press the SWEEP key.
- Press the TRIGGER softkey.
- Using the cursor keys or the rotary knob, select the menu item EXTERN ] for triggering on the positive edge or EXTERN ] for triggering on the negative edge and confirm your selection with the ENTER key or the TRIGGER softkey.

As long as no triggering is occurring, a blue dot will appear at the top right of the measurement screen.

**Setting the trigger delay:**

You can use DELAY... to delay the trigger event. The trigger delay resolution depends on the delay selected.

Trigger delay (DELAY)	Resolution
0 to 1 ms	10 $\mu$ s
1 ms to 10 ms	100 $\mu$ s
10 ms to 100 ms	1 ms
100 ms to 1 s	10 ms
1 s to 10 s	100 ms
10 s to 100 s	1 s

- Use the cursor keys or the rotary knob to select DELAY... and confirm your input with the ENTER key or by pressing the DELAY... softkey.

The R&S FSH3-TV will open the field for entering the delay.

- Use the keypad, cursor keys or the rotary knob to enter the delay and confirm your input with the ENTER key or by pressing the TRIGGER softkey.

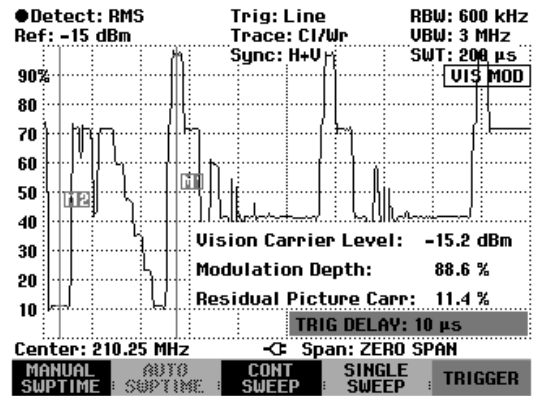

**Setting the Time Basis**

In the Vision Modulation operating mode, the default setting for the time range is 200  $\mu$ s. You can set the time range from 148  $\mu$ s to 100 s.

- Press the SWEEP key.
- Press the MANUAL SWPTIME key.

The R&S FSH3-TV will open the field for entering the time range.

- Using the number keys, enter the appropriate time range and terminate the entry with the appropriate unit key, or
- Change the time range with the rotary knob or the cursor keys.

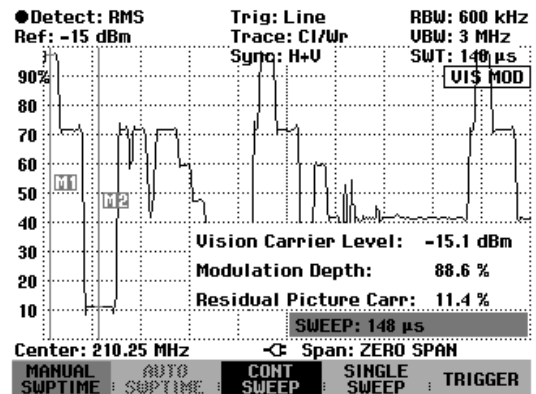

## Markers in the Vision Modulation Operating Mode

In order to compute the modulation parameters, the vision carrier power is scanned at the instant of the sync level and the white level. In the default setting, the marker positions are set depending on the setting of the test line. You can also offset the marker positions manually. This allows you to make the measurement in arbitrary test lines.

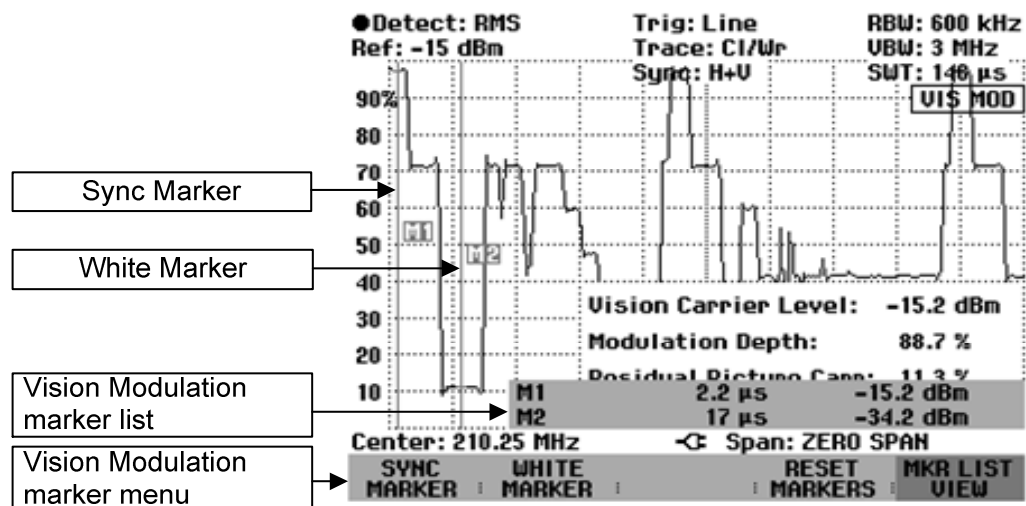

### Setting the markers for measuring the vision carrier modulation parameters:

- Press the MARKER key.
- Press the SYNC MARKER softkey.
- Use the cursor keys, the rotary knob or a numerical input to set the sync marker to the sync pulse.
- Press the WHITE MARKER softkey.

Use the cursor keys, the rotary knob or a numerical input to set the white marker to the white pulse.

The marker positions are referred to the leading edge of the trigger line.

### Resetting the marker positions:

In the default setting, the marker positions are matched to the setting for the test line. You can use Reset Markers to re-create this.

- Press the MARKER key.
- Press the RESET MARKERS softkey.

The R&S FSH3-TV will reset the marker positions depending on the set test line.

### Displaying the marker parameters:

You can show the marker parameters in the display.

- Press the MARKER key.
- Press the MKR LIST VIEW softkey.

The marker positions and the associated time and the level values will appear in the display.

**Hiding the marker values:**

- Press the MARKER key.
- Press the MKR LIST VIEW softkey.

The marker list is displayed if the softkey has a red background.

**Trace Modes**

A variety of display modes can be selected for the trace:

- CLEAR/WRITE                      The R&S FSH3-TV clears the old trace during a new sweep. This is the default setting.
- AVERAGE                          The R&S FSH3-TV computes the average value of the level based on consecutive measured traces. In the default setting, averaging is on a pixel-by-pixel basis and is sliding over the ten previous traces. Alternatively, you can set the number for the averaging from 2 to 999. This can help to suppress noise and produce more stable measured values, for example.
- MAX HOLD                          The trace indicates the maximum value that has been measured up to that point in time. The R&S FSH3-TV interrupts the Max Hold mode only if another setting is selected and the trace pixels from the new setting cannot be compared with the trace pixels from the previous setting – for example if the time range is changed.
- MIN HOLD                          The trace indicates the minimum value that has been measured up to that point in time. The R&S FSH3-TV interrupts the Min Hold mode only if another setting is selected and the trace pixels from the new setting cannot be compared with the trace pixels from the previous setting – for example if the time range is changed.
- VIEW                                  The R&S FSH3-TV freezes the currently displayed trace. The measurement is aborted. This, for instance, allows subsequent evaluation of signals with the aid of the marker.



**Operating sequence:**

- Press the TRACE key.
- Press the TRACE MODE softkey.

The R&S FSH3-TV opens the submenu with trace mode settings.

- Use the cursor keys or the rotary knob to select the desired Trace Mode and accept the input with the ENTER key or the TRACE MODE softkey.

The "Trace:" indicator at the top center of the display shows the current setting.

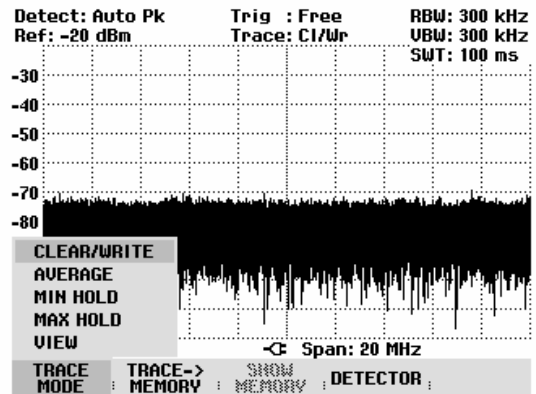

If TRACE MODE AVERAGE is selected, the AVG COUNT entry field opens, which displays the set number of averagings.

The following actions can be performed:

- Confirm the displayed number of averagings with the TRACE softkey or the ENTER key.
- Using the numeric keypad, enter a new figure between 2 and 999 for specifying the number of averagings and confirm your entry with the TRACE softkey or the ENTER key.
- Change the number of averagings by using the rotary knob and confirm your entry with the TRACE softkey or the ENTER key.

The R&S FSH3-TV averages the pixels of the trace over the set number of averagings.

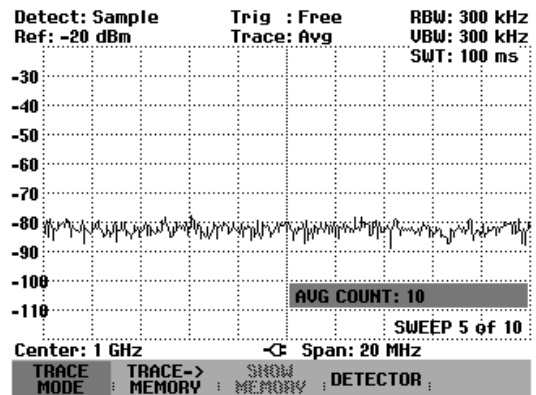

If the sweep is continuous, the instrument then performs a sliding averaging. In the SINGLE SWEEP mode, it performs exactly those sweeps defined with AVG COUNT and averages the traces. It then stops the sweep and displays the averaged trace.

In the trace mode VIEW, the settings used for measuring the trace are displayed. This ensures that the measurement conditions are clearly specified in result documentation. In the status display (STATUS key), an indication is made in parentheses that the view mode is currently selected, e.g. Trace Mode: Maximum Hold (View).

## Trace Memory

The R&S FSH3-TV can transfer a trace to the trace memory and also display the current trace and the trace in the trace memory for comparison. The saved trace is always displayed in white to distinguish it from the current trace.

### Operating sequence:

- Press the TRACE key.
- Press the TRACE -> MEMORY softkey.

The R&S FSH3-TV transfers the currently displayed trace to the trace memory.

- Press the SHOW MEMORY softkey.

The R&S FSH3-TV displays the saved trace in white. The SHOW MEMORY softkey is highlighted in green to indicate that the trace in the trace memory is being displayed.

- To remove the saved trace from the screen, press the SHOW MEMORY softkey again.

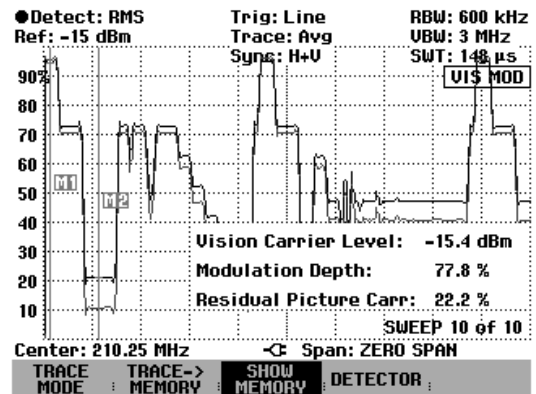

**Note:** *The R&S FSH3-TV saves the memory trace as a bit map in the screen memory. This means that it does not adapt the memory trace to the modified reference level or time range.*

## Measuring the Carrier Levels and Carrier Frequencies

In the CARRIER MEASUREMENTS operating mode, the R&S FSH3-TV measures the power and frequency of the vision carrier and the power and frequency spacing of the sound carriers with respect to the vision carrier.

Note: The video output signal is not available in the VISION MODULATION operating mode.

### Screen Layout

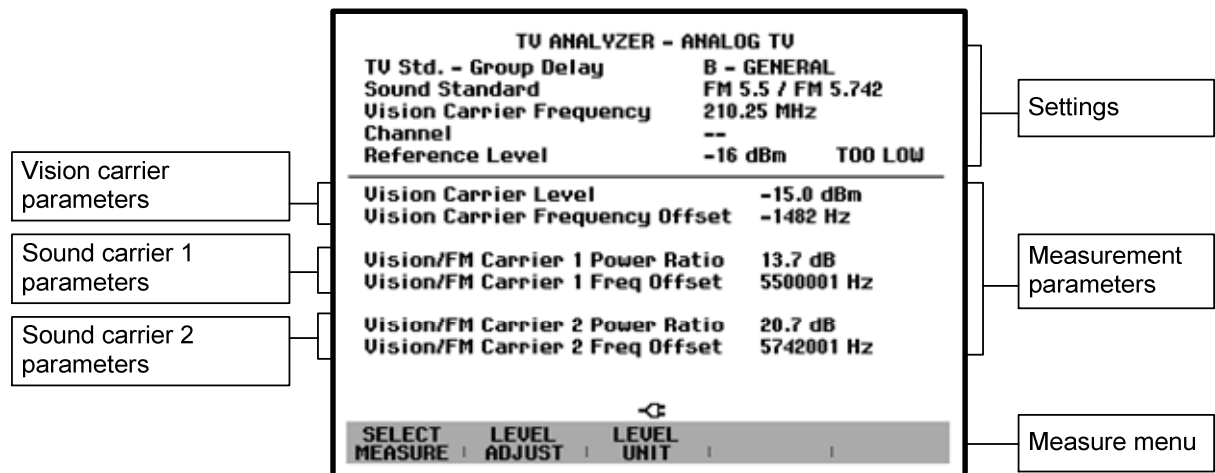

The instrument settings that are shown are dependent on the selected standard.

Instrument settings	Explanation
<b>TV std – group delay</b>	The selected analog TV standard and the group delay equalization of the video signal are displayed. You can select the standard in the SETUP – LOCAL SETTINGS – ANALOG TV menu.
<b>Sound standard</b>	This sound transmission standard that you have selected is displayed. You can select this sound standard along with the setting for the TV standard and the group delay equalization in the SETUP – LOCAL SETTINGS – ANALOG TV menu.
<b>Vision carrier frequency</b>	The vision carrier frequency you have selected is displayed.
<b>Channel</b>	The channel number and information about the selected channel are displayed. Information is displayed also when you are setting the vision carrier frequency, but only if the setting for the vision carrier frequency matches a corresponding vision carrier frequency of a channel in the selected channel table. A frequency offset of up to 40 kHz is tolerated.
<b>Reference level</b>	<p>The reference level which is set is displayed in the measurement screen.</p> <p>In case of overdrive, "TOO LOW" is shown next to the set value. In this case, the reference level must be increased.</p> <p>To simplify operation and to avoid incorrect measurements, the R&amp;S FSH3-TV is equipped with an automatic routine (LEVEL ADJUST) for setting the optimum reference level. In the Carrier Measurements operating mode, the setting criterion for the LEVEL ADJUST function is the vision carrier level.</p>

The measurement parameters that are shown are dependent on the selected standard.

Parameter	Explanation
<b>Vision carrier level</b>	The maximum vision carrier power for the received useful signal is displayed using the selected unit.
<b>Vision carrier frequency offset</b>	The frequency offset of the vision carrier with respect to the set vision carrier frequency is displayed.
<b>Vision / FM carrier power ratio</b>	The power ratio of the vision carrier to the corresponding FM sound carrier is displayed.
<b>Vision / FM carrier freq offset</b>	The frequency offset of the vision carrier to the corresponding FM sound carrier is displayed.
<b>Vision / NICAM carrier power ratio</b>	The power ratio of the vision carrier to the NICAM carrier is displayed.
<b>Vision / NICAM carrier freq offset</b>	The frequency offset of the vision carrier to the NICAM carrier is displayed.

### Switching on the Carrier Measurements Operating Mode

Switching on the Carrier Measurements operating mode if the analog TV receiver is already activated:

- Press the MEAS key until the F1 function key displays SELECT MEASURE.
- Press the SELECT MEASURE softkey.
- Using the rotary knob or the cursor keys, select CARRIER MEASUREMENTS and confirm your choice with the ENTER key or the SELECT MEASURE softkey.

The Carrier Measurements screen should appear in the display. The function keys for the menus should be switched.

Switching on the Carrier Measurements operating mode if another measurement mode besides analog TV receiver is already activated:

- Press the MEAS key until the F1 function key displays MEASURE.
- Using the rotary knob or the cursor keys, select ANALOG TV RECEIVER and confirm your choice with the ENTER key or the MEASURE softkey.
- Using the rotary knob or the cursor keys, select CARRIER MEASUREMENTS and confirm your choice with the ENTER key or the SELECT MEASURE softkey.

The Carrier Measurements screen should appear in the display. The function keys for the menus should be switched.

## **Level Adjust**

To simplify operation and to avoid incorrect measurements, the R&S FSH3-TV is equipped with an automatic routine (LEVEL ADJUST) for setting the optimum reference level. In the Carrier Measurements operating mode, the setting criterion for the LEVEL ADJUST function is the vision carrier level.

- Press the MEAS key until the F1 function key displays SELECT MEASURE.
- Press the LEVEL softkey.
- Start the routine with the ENTER key or the LEVEL softkey.

While the R&S FSH3-TV is looking for the optimum reference level, it will show a corresponding message on the display.

## **Setting the Unit for the Vision Carrier Level**

The measured vision carrier level can be displayed in either dBm, dBmV or dB $\mu$ V.

- Press the MEAS key until the F1 function key displays SELECT MEASURE.
- Press the LEVEL UNIT softkey.
- Using the rotary knob or the cursor keys, select the unit you want and confirm your choice with the ENTER key or the LEVEL UNIT softkey.

## Measuring the Hum Modulation

In the HUM MEASUREMENT operating mode, the R&S FSH3-TV measures the hum modulation of the vision carrier. For this measurement, the vision carrier is filtered with a bandwidth of 600 kHz. This ensures that sound carriers, color subcarriers and adjacent channels are suppressed and that the sync pulses are transmitted without any power degradation. The filtered vision carrier signal is sampled at the time of the sync pulse. As a result, the video information is removed from the measurement signal. The trace shows the envelope curve for the sync pulse amplitude values of the vision carrier.

### Definition of Hum Modulation

The R&S FSH3-TV measures the hum modulation ratio in conformity with the EN 50083 standard. The hum modulation ratio is defined as the ratio, expressed in dB, of the amplitude of the unmodulated carrier to the peak-to-peak value of the envelope curve produced by the hum modulation.

$$HUM = 20 \cdot \lg \left[ \frac{2 \cdot (Avg\_VisionCarrierAmplitude)}{Max\_VisionCarrierAmplitude - Min\_VisionCarrierAmplitude} \right]$$

$$HUM = 20 \cdot \lg \left[ \frac{Max\_VisionCarrierAmplitude + Min\_VisionCarrierAmplitude}{Max\_VisionCarrierAmplitude - Min\_VisionCarrierAmplitude} \right]$$

### Screen Layout

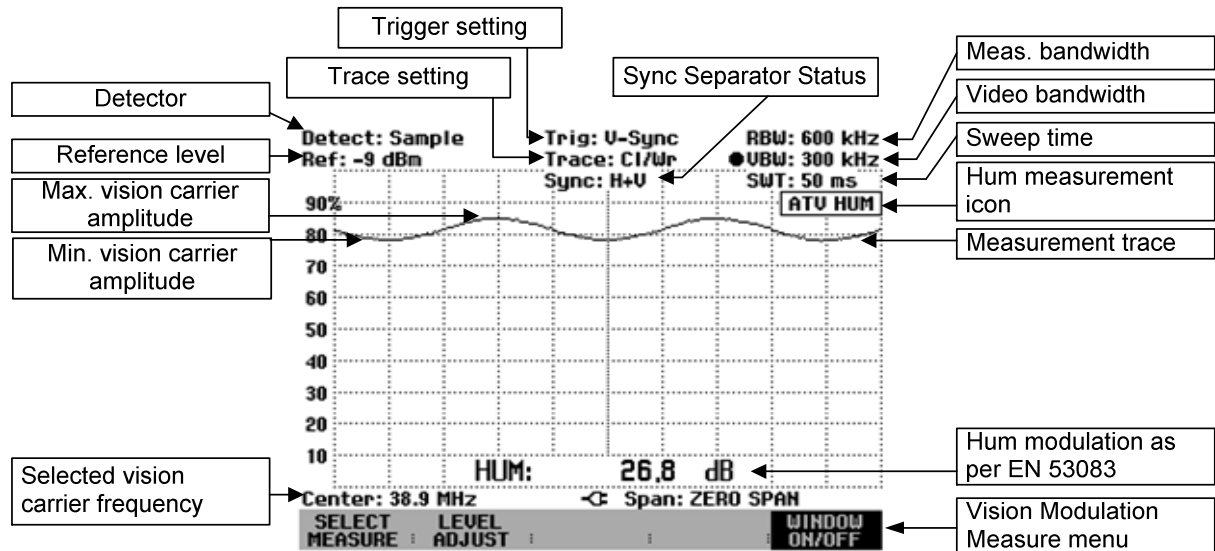

## **Switching on the Hum Measurement Operating Mode**

Switching on the Hum Measurement operating mode if the analog TV receiver is already activated:

- Press the MEAS key until the F1 function key displays SELECT MEASURE.
- Press the SELECT MEASURE softkey.
- Using the rotary knob or the cursor keys, select HUM MEASUREMENT and confirm your choice with the ENTER key or the SELECT MEASURE softkey.

The Hum Measurement screen should appear in the display. The function keys for the menus should be switched. When the Hum Measurement operating mode is launched, the instrument settings are set to their defaults.

Switching on the Hum Measurement operating mode if another measurement mode besides analog TV receiver is already activated:

- Press the MEAS key until the F1 function key displays MEASURE.
- Using the rotary knob or the cursor keys, select ANALOG TV RECEIVER and confirm your choice with the ENTER key or the MEASURE softkey.
- Using the rotary knob or the cursor keys, select HUM MEASUREMENT and confirm your choice with the ENTER key or the SELECT MEASURE softkey.

The Hum Measurement screen should appear in the display. The function keys for the menus should be switched. When the Hum Measurement operating mode is launched, the instrument settings are set to their defaults.

## **Level Adjust**

To simplify operation and to avoid incorrect measurements, the R&S FSH3-TV is equipped with an automatic routine (LEVEL ADJUST) for setting the optimum reference level. In the Vision Modulation operating mode, the setting criterion for the LEVEL ADJUST function is the vision carrier level.

- Press the MEAS key until the F1 function key displays SELECT MEASURE.
- Press the LEVEL softkey.
- Start the routine with the ENTER key or the LEVEL softkey.

While the R&S FSH3-TV is looking for the optimum reference level, it will show a corresponding message on the display.

### Triggering in Hum Measurement Operating Mode

Triggering can be set to the received TV signal or to an external signal which is applied to the multi-function BNC jack.

- V-SYNC... Triggering is based on the vertical sync pulse of the demodulated video signal. This is the default setting. If the amplitude filter does not detect any vertical sync pulses, the R&S FSH3-TV starts a new sweep as soon as the previous one is completed. This is the default setting.
- VIDEO... A sweep starts when the video voltage exceeds a settable value. If the trigger setting VIDEO... was selected, you must enter the trigger level. The trigger level is expressed as a percentage (%) of the reference level. 100% means that the trigger level equals the reference level, 50% that the trigger level is in the middle of the Y axis on the measurement diagram (default setting). The R&S FSH3-TV shows the position of the video trigger level using a ">" on the level axis.
- EXTERN  $\lrcorner$  and EXTERN  $\lrcorner$  The sweep is started on the rising edge ( $\lrcorner$ ) or on the falling edge ( $\lrcorner$ ) of an external trigger signal. The external trigger signal is fed in via the multi-function BNC jack. The switching threshold is 1.4 V, i.e. a TTL signal level. In the SETUP / HARDWARE SETUP menu, you must set EXT TRIG.
- DELAY... You can set a triggering delay. In this way, time differences between the trigger event and the measurement can be allowed for.

The current trigger setting is displayed centrally at the top of the screen.

#### Operating sequence:

- Press the SWEEP key.
- Press the TRIGGER softkey.

The R&S FSH3-TV opens the menu for selecting the trigger.

- Use the cursor keys or the rotary knob to select the desired trigger and accept the input with the ENTER key or the TRIGGER softkey.

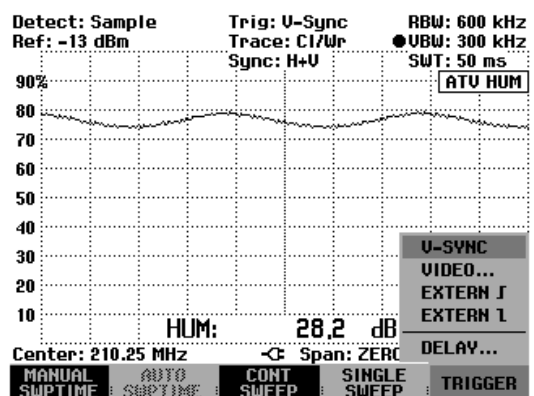

#### Triggering on the video sync pulse of the demodulated TV signal:

- Press the SWEEP key.
- Press the TRIGGER softkey.
- Using the rotary knob or the cursor keys, select V-SYNC... from the menu and confirm your choice with the ENTER key or the TRIGGER softkey.



**Triggering on the amplitude of the displayed measurement trace:**

If the trigger setting VIDEO... was selected, you must enter the trigger level. The trigger level is expressed as a percentage (%) of the reference level. 100% means that the trigger level equals the reference level, 50% that the trigger level is in the middle of the Y axis on the measurement diagram (default setting). The R&S FSH3-TV shows the position of the video trigger level using a ">" on the level axis.

In this setting, it is possible to trigger in response to the hum modulation.

- Use the cursor keys or the rotary knob to change the video trigger threshold (0 – 100 %).

The trigger threshold will be changed immediately after your input.

or

- Confirm the entry for the trigger threshold with the ENTER key or the TRIGGER softkey.

The R&S FSH3-TV closes the entry field.

**Triggering on an external signal with TTL levels:**

- Press the SETUP key.
- Press the HARDWARE SETUP softkey.
- Using the cursor keys or the rotary knob, select EXT TRIG from the menu and confirm your choice with the ENTER key or the HARDWARE SETUP softkey.
- Press the SWEEP key.
- Press the TRIGGER softkey.
- Using the cursor keys or the rotary knob, select the menu item EXTERN ] for triggering on the positive edge or EXTERN ] for triggering on the negative edge and confirm your selection with the ENTER key or the TRIGGER softkey.

As long as no triggering is occurring, a blue dot will appear at the top right of the measurement screen.

**Setting the trigger delay:**

You can use DELAY... to delay the trigger event. The trigger delay resolution depends on the delay selected.

Trigger delay (DELAY)	Resolution
0 to 1 ms	10 µs
1 ms to 10 ms	100 µs
10 ms to 100 ms	1 ms
100 ms to 1 s	10 ms
1 s to 10 s	100 ms
10 s to 100 s	1 s

- Use the cursor keys or the rotary knob to select DELAY... and confirm your input with the ENTER key or by pressing the DELAY... softkey.

The R&S FSH3-TV will open the field for entering the delay.

- Use the keypad, cursor keys or the rotary knob to enter the delay and confirm your input with the ENTER key or by pressing the TRIGGER softkey.

### Setting the Time Basis

In the Hum Modulation operating mode, the default setting for the time range is 50 ms. You can set the time range from 20 ms to 1 s.

➤ Press the SWEEP key.

The R&S FSH3-TV will open the field for entering the time range.

- Using the number keys, enter the appropriate time range and terminate the entry with the appropriate unit key, or
- Change the time range with the rotary knob or the cursor keys.

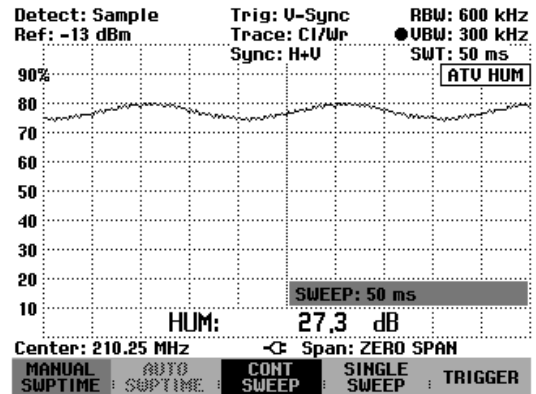

### Markers

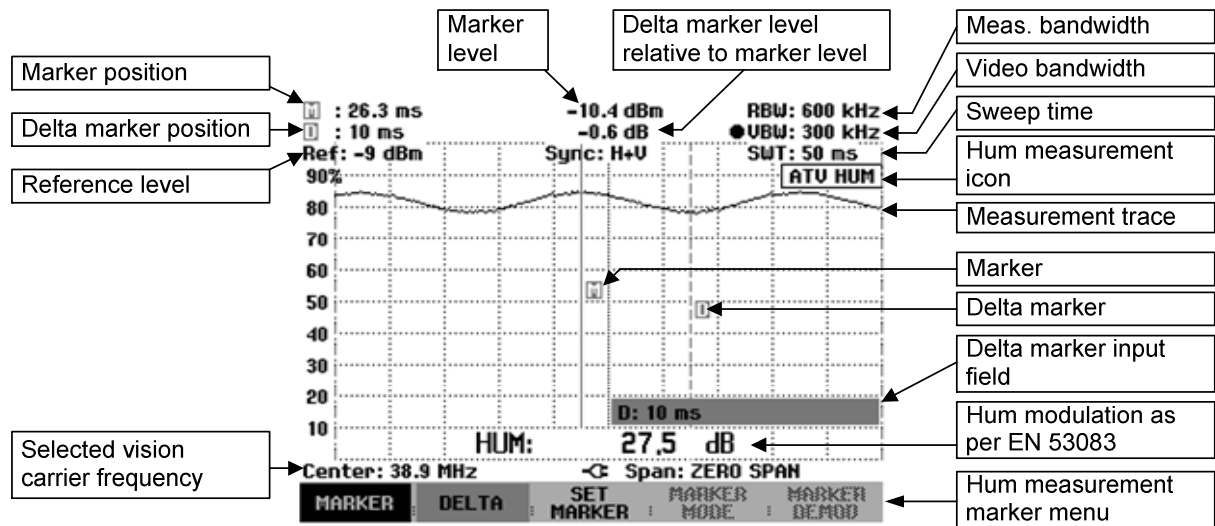

In the Hum Measurement operating mode, a marker and a delta marker are available. Using the SET MARKER functions, you can place the marker on the highest, the next highest or the lowest amplitude value.

The amplitude and position of the delta marker are referred to the marker.

## Trace Functions

A variety of display modes can be selected for the trace:

- CLEAR/WRITE                      The R&S FSH3-TV clears the old trace during a new sweep. This is the default setting.
- AVERAGE                              The R&S FSH3-TV computes the average value of the level based on consecutive measured traces. In the default setting, averaging is on a pixel-by-pixel basis and is sliding over the ten previous traces. Alternatively, you can set the number for the averaging from 2 to 999. This can help to suppress noise and produce more stabled measured values, for example. This setting makes sense only if the hum modulation is in sync with the trigger signal.
- MAX HOLD                              The trace indicates the maximum value that has been measured up to that point in time. The R&S FSH3-TV interrupts the Max Hold mode only if another setting is selected and the trace pixels from the new setting cannot be compared with the trace pixels from the previous setting – for example if the time range is changed.
- MIN HOLD                              The trace indicates the minimum value that has been measured up to that point in time. The R&S FSH3-TV interrupts the Min Hold mode only if another setting is selected and the trace pixels from the new setting cannot be compared with the trace pixels from the previous setting – for example if the time range is changed.
- VIEW                                      The R&S FSH3-TV freezes the currently displayed trace. The measurement is aborted. This, for instance, allows subsequent evaluation of signals with the aid of the marker.

**Operating sequence:**

- Press the TRACE key.
- Press the TRACE MODE softkey.

The R&S FSH3-TV opens the submenu with trace mode settings.

- Use the cursor keys or the rotary knob to select the desired Trace Mode and accept the input with the ENTER key or the TRACE MODE softkey.

The "Trace:" indicator at the top center of the display shows the current setting.

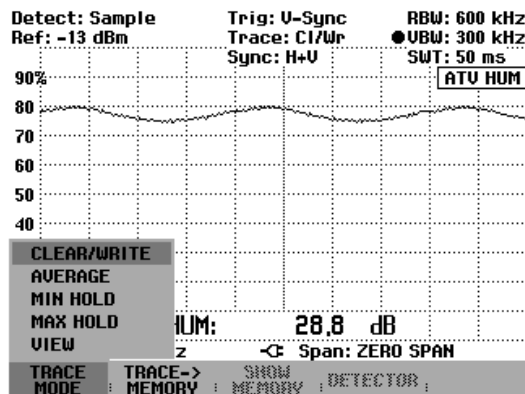

If TRACE MODE AVERAGE is selected, the AVG COUNT entry field opens and displays the set number of averagings.

The following actions can be performed:

- Confirm the displayed number of averagings with the TRACE softkey or the ENTER key.
- Using the numeric keypad, enter a new number between 2 and 999 for the number of averagings and confirm your entry with the TRACE softkey or the ENTER key.
- Change the number of averagings by using the rotary knob and confirm your entry with the TRACE softkey or the ENTER key.

The R&S FSH3-TV averages the pixels of the trace over the set number of averagings.

If the sweep is continuous, the instrument then performs a sliding averaging. In SINGLE SWEEP mode, it performs exactly those sweeps defined with AVG COUNT and averages the traces. It then stops the sweep and displays the averaged trace.

In the VIEW trace mode, the settings used for measuring the trace are displayed. This ensures that the measurement conditions are clearly specified in result documentation. In the status display (STATUS key), an indication is made in parentheses that the view mode is currently selected, e.g. Trace Mode: Maximum Hold (View).

## Operation as a Digital TV Receiver

(only available with the R&S FSHTV-K21 or R&S FSHTV-K22 software option)

The R&S FSH3-TV demodulates digital TV signals as are distributed in cable systems in compliance with the J.83/A/B/C QAM standards. The R&S FSHTV-K21 software option is needed to enable the QAM demodulator.

The R&S FSH3-TV also demodulates terrestrial transmission signals in compliance with the 8VSB/ATSC standard. To enable the 8VSB/ATSC demodulator, the R&S FSHTV-K22 software option is required.

Three modes are available for displaying the measurement results:

- **Measurement List**  
The measurement parameter list provides an overview of the presence and quality of the set receive signal.
- **Constellation Diagram**  
The constellation diagram allows qualitative assessment of the digital receive channel.
- **Shoulder Attenuation**  
In Shoulder Attenuation operating mode, the shoulder attenuation of QAM signals is measured in compliance with the technical guideline ETSI TR 101 290. 8VSB/ATSC signals are measured in compliance with the FCC recommendation.

In the Measurement List and Constellation Diagram operating modes, the asynchronous serial transport stream TS-ASI is provided on the instrument's BNC jack.

*Note: In the Shoulder Attenuation operating mode, the asynchronous serial transport stream TS-ASI is not available.*

### Switching on the digital TV receiver:

- Press the MEAS key.
- Press the MEASURE softkey.

The R&S FSH3-TV will open the menu for the measurement functions.

- Using the cursor keys or the rotary knob, select DIGITAL TV RECEIVER from the menu and confirm your choice with the ENTER key or the MEASURE softkey.

The R&S FSH3-TV will open the submenu for selection of the DIGITAL TV RECEIVER operating mode.

- Using the cursor keys or the rotary knob, select the desired operating mode and confirm your choice with the ENTER key or the MEASURE softkey.

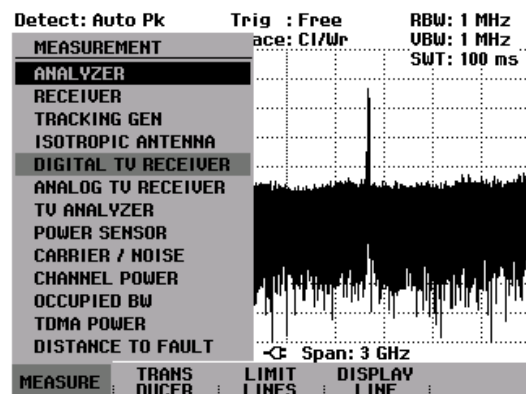

## Setting the Digital TV Standard

- Press the SETUP key.
- Press the LOCAL SETTINGS softkey.
- Using the cursor keys or the rotary knob, select DIGITAL TV STANDARD from the menu and confirm your choice with the ENTER key or the LOCAL SETTINGS softkey.
- Using the cursor keys or the rotary knob, select the desired standard and confirm your choice with the ENTER key or the LOCAL SETTINGS softkey.

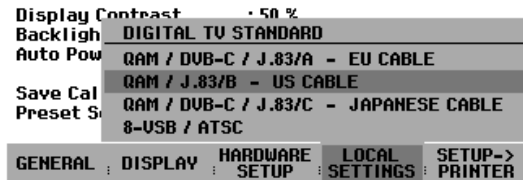
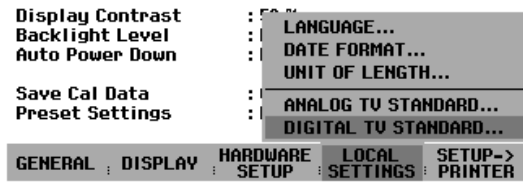

## Setting the Receive Frequency

You can set the frequency by inputting the center frequency or the channel number. For the 8VSB/ATSC standard, you can also input the pilot frequency.

### Setting the center frequency

- Press the FREQ key.

The R&S FSH3-TV opens the entry field for setting the center frequency.

- Use the rotary knob, the cursor keys or a numerical entry to set or change the center frequency.

Any change in the frequency setting when using the rotary knob will depend on the setting for the FREQ STEPSIZE.

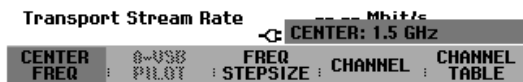

### Setting the pilot frequency:

You can input the pilot frequency only for the 8VSB/ATSC standard.

- Press the FREQ key.
- Press the 8VSB PILOT softkey.

The R&S FSH3-TV opens the entry field for the pilot frequency.

- Use the rotary knob, the cursor keys or a numerical entry to change the pilot frequency.

Any change in the frequency setting when using the rotary knob will depend on the setting for the FREQ STEPSIZE.

The R&S FSH3-TV computes the relationship between the 8VSB pilot frequency and the center frequency based on the sideband setting. When the 8VSB/ATSC standard is selected, the R&S FSH3-TV has a fixed setting to a standard symbol rate of 10762238 symbols per second.

Sideband	Relationship between 8VSB pilot frequency and center frequency
Upper sideband	8VSB pilot frequency = center frequency – symbol rate / 4
Lower sideband	8VSB pilot frequency = center frequency + symbol rate / 4

**Setting the frequency stepsize:**

You can set the stepsize for use in determining the frequency with the rotary knob or the cursor keys. In the default setting, the stepsize is dependent on the channel bandwidth (which is dependent on the standard).

- Press the **FREQ** key.
- Press the **FREQ STEPSIZE** softkey.



The R&S FSH3-TV opens the entry field for inputting the frequency stepsize.

- Enter the desired stepsize into the input field using the keypad and confirm your entry with the corresponding unit key, or change the stepsize with the rotary control or the cursor keys.

**Frequency Tuning in Channel Spacings**

As an alternative to frequency input, the R&S FSH3-TV allows you to tune the frequency using channel spacings. A simple channel table can be defined directly from the R&S FSH3-TV's front panel. Complicated channel tables, e.g. ones with gaps in the channel numbers or the frequency, must be defined using the R&S FSH View software and loaded into the R&S FSH3-TV's memory.

- Press the **FREQ** key.
- Press the **CHANNEL** softkey.

The R&S FSH3-TV opens the entry field for inputting the channel number. Set the frequency corresponding to the selected channel table.

- Enter the desired channel number into the input field using the keypad and confirm your entry with the **ENTER** key, or change the channel number with the rotary control or the cursor keys.

If you try to enter a channel outside of the defined range, the R&S FSH3-TV displays "Range exceeded".

*Note: The channel table shows the reference between a channel number and channel center frequency. The R&S FSH3-TV computes the 8VSB pilot frequency based on the setting for the sideband.*

A channel table is selected as follows:

- Press the **CHANNEL TABLE** softkey.

The R&S FSH3-TV switches to the submenu for selecting the channel configuration. All channel tables available in the instrument that were loaded with the R&S FSH View software are displayed. If no channel table is loaded, the R&S FSH3-TV displays "No bands available".

30/03/2004	BAND TABLE LIST	22:10:16
TU France	01/03/2004 15:59:02	
TU Japan	01/03/2004 14:58:52	
TU DK_DIRT	01/03/2004 14:40:20	
TU Australia	01/03/2004 14:40:08	
TU Europe	01/03/2004 14:39:56	
TU China	01/03/2004 14:34:40	
TU Italy	01/03/2004 14:30:40	
TU Ireland	01/03/2004 14:30:26	
TU French Overs	01/03/2004 14:30:16	
PCS UL	01/01/1995 02:00:00	
PCS DL	01/01/1995 02:00:00	
GSM UL	01/01/1995 02:00:00	
GSM DL	01/01/1995 02:00:00	

- Select the desired channel table using the rotary knob or the cursor keys.
- Confirm your selection with the **SELECT** softkey.

The R&S FSH3-TV will switch back to the measurement screen.

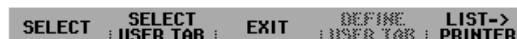

If no channel table is stored in the instrument or a different one is necessary, a user table can also be defined.

To define a user table, proceed as follows:

- Press the **FREQ** key.
- Press the **CHANNEL TABLE** softkey.
- Press the **SELECT USER TAB** softkey.
- Press the **DEFINE USER TAB** softkey.

The R&S FSH3-TV opens the submenu for entering the different parameters of the channel table. A channel table is defined by the number used for the first channel and the associated frequency, and by the number of channels and their frequency spacing.



- Select 1<sup>ST</sup> CHANNEL NO... by pressing the **ENTER** key.
- Enter the number of the first channel and confirm the entry with the **ENTER** key.
- Press the **DEFINE USER TAB** softkey.
- Select 1<sup>ST</sup> CHANNEL FREQ... from the menu and confirm with the **ENTER** key.
- Enter the frequency of the first channel and terminate the entry with the frequency unit.
- Press the **DEFINE USER TAB** softkey.
- Select NO OF CHANNELS... from the menu and confirm with the **ENTER** key.
- Enter the number of channels and confirm the entry with the **ENTER** key.
- Press the **DEFINE USER TAB** softkey.
- Select CHANNEL SPACING... from the menu and confirm with the **ENTER** key.
- Enter the channel spacing for the channels and terminate the entry with the required unit key.



## Setting the Reference Level

The reference level (REF LEVEL) controls the sensitivity of the digital TV receiver. Set the reference level so that the receiver is neither overdriven nor underdriven. This is the case when the modulation error or the vector error of the demodulated signal is at a minimum or the shoulder attenuation is at a maximum. The R&S FSH3-TV measures the modulation error and displays it in the Measurement List and Constellation Diagram operating modes. In the Shoulder Attenuation operating mode, set the reference level so that the highest possible shoulder attenuation is attained.

There is no fixed relationship between the useful received level and the reference level setting since the optimum setting is dependent on the overall received signal and not just the level of the useful channel.

In the Shoulder Attenuation operating mode, you can directly see the effect of the reference level setting in the measurement trace. In the Measurement List and Constellation Diagram operating modes, the difference with respect to the ideal demodulator level is displayed after the set reference level as an aid in making the setting.

## Manual Entry of the Reference Level

The reference level is set manually in the AMPT menu.

- Press the AMPT key.

The R&S FSH3-TV opens the entry field for setting the reference level.

- Modify the set reference level using the cursor keys or the rotary knob, or
- Enter a reference level with the number keys and either terminate the entry with one of the unit keys (-dBm or dBm for relative measurements or (), m,  $\mu$ , n for absolute measurements).

## Selecting the Reference Level Unit

The reference level can be entered in dBm, dB $\mu$ V, dBmV, V or W.

- Press the AMPT key.
- Press the UNIT softkey.
- Change the reference level setting with the cursor keys or the rotary knob, or enter a new reference level via the numeric keypad.

## Entering the Reference Offset

- Press the AMPT key.
- Press the REF OFFSET softkey.
- Using the number keys, enter a reference offset and terminate the entry with one of the unit keys or the ENTER key, or
- Change the reference level with the rotary knob or the cursor keys.

The reference offset unit is always dB – no matter what unit is used for the reference level.

To indicate that a non-zero reference offset has been set, the R&S FSH3-TV places a red circle before the reference level readout.

## Entering the Input Impedance

- Press the AMPT key.
- Press the RF INPUT softkey.

A submenu opens and the two input impedance options “50  $\Omega$ ” and “75  $\Omega$ ” are displayed.

- Using the rotary knob or the cursor keys, select the input impedance you want and confirm your selection by pressing the ENTER key.

*Note: If the input is set to 75  $\Omega$ , you will definitely need a resistive adapter on the RF input. Otherwise, the R&S FSH3-TV will display the wrong level. We recommended the R&S FSH-Z38 adapter (order No. 1300.7740.02).*

## Inputting the Display Range

In the Shoulder Attenuation operating mode, you can modify the scaling. The default setting is logarithmic scaling with 10 dB per division.

- Press the AMPT key.
- Press the RANGE softkey.

A menu box opens on the R&S FSH3-TV and the various options for scaling the level axis are displayed.

- Using the cursor keys or the rotary knob, select the desired scaling and confirm your choice with the ENTER key or the RANGE softkey.

The R&S FSH3-TV automatically sets the desired scaling.

## Automatic Routine for Setting the Optimum Reference Level

To simplify operation and to prevent incorrect measurements, the R&S FSH3-TV has an automatic routine for setting the reference level.

In the Parameter List und Constellation Diagram operating modes, the LEVEL ADJUST function measures the modulation error of the demodulated signal as a function of the reference level and sets the reference level so that the lowest modulation error is attained. This ensures that the receiver is optimally set, irrespective of the channels and levels of the input signal.

In the Shoulder Attenuation mode, the LEVEL ADJUST function measures the shoulder attenuation depending on the reference level, and sets the reference level to maximize the shoulder attenuation. This ensures that the receiver is optimally set, irrespective of the channels and levels of the input signal.

### Launching the LEVEL ADJUST routine in the Measurement List and Constellation Diagram operating modes:

- Press the MEAS key.
- Press the LEVEL ADJUST softkey.

The R&S FSH3-TV sets the reference level so that the vector error of the demodulation signal is at a minimum.

### Launching the LEVEL ADJUST routine in the Shoulder Attenuation operating mode:

- Press the MEAS key.
- Press the LEVEL softkey.
- Using the rotary knob or the cursor keys, select LEVEL ADJUST UPPER SHOULDER or LEVEL ADJUST LOWER SHOULDER and confirm your choice with the ENTER key or the LEVEL softkey.

The R&S FSH3-TV sets the reference level so that the maximum shoulder attenuation is attained.

## Setting the QAM Order

The R&S FSH3-TV demodulates single carrier signals with quadrature amplitude modulation. For the J.83/A and J.83/C QAM standards, the instrument supports 4QAM, 16QAM, 32QAM, 64QAM, 128QAM and 256QAM. In the default setting (QAM J.83/B), the instrument supports 64QAM and 256QAM.

- Press the BW key.
- Press the QAM ORDER softkey.
- Using the rotary knob or the cursor keys, select the desired QAM order and confirm your choice with the ENTER key or the BW softkey.

## Setting the Symbol Rate

The R&S FSH3-TV demodulates QAM signals with symbol rates from 2 MHz to 6.999 MHz.

- Press the BW key.
- Press the SYMBOL RATE softkey.

The R&S FSH3-TV opens the entry field for setting the symbol rate.

- Use the rotary knob, the cursor keys or a numerical entry to set or change the symbol rate.

The default setting is dependent on the standard.

Standard	Symbol rate
DVB-C in conformity with J.83/A standard	6 900 000 Hz
US cable in conformity with J.83/B 64QAM	5 056 941 Hz
US cable in conformity with J.83/B 256QAM	5 360 537 Hz
DVB-C in conformity with J.83/C standard	5 273 979 Hz
8VSB in conformity with ATSC	10 762 238 Hz

*Note: For the 8VSB/ATSC standard, you cannot modify the symbol rate. It is set to a fixed value of 10 762 238 Hz.*

## Selecting the Sideband

The R&S FSH3-TV demodulates digital TV signals with a normal sideband setting or an inverted sideband setting. With the QAM standards, it is possible to enable automatic operation. The R&S FSH3-TV automatically determines the sideband setting for the received digital TV signal. With the 8VSB/ATSC standard, automatic operation is not possible.

- Press the BW key.
- Press the SIDEBAND POSITION softkey.
- Using the cursor keys or the rotary knob, select the desired setting and confirm your choice with the ENTER key or the SIDEBAND POSITION softkey.

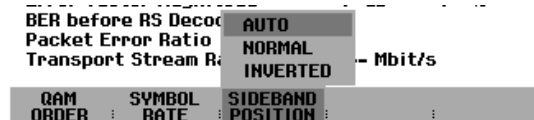

## TS-ASI Output

In the Measurement List and Constellation Diagram operating modes, the R&S FSH3-TV provides the asynchronous MPEG transport stream TS-ASI with a 75 Ohm source impedance on the instrument's BNC jack. In order to provide the TS-ASI signal, you must set the multi-function BNC jack in the SETUP / HARDWARE SETUP / BNC I/O MODE menu to TS-ASI OUT.

*Note: The TS-ASI signal is not available in the Shoulder Attenuation operating mode.*

### Switching on the TS-ASI output:

- Press the SETUP key.
- Press the HARDWARE SETUP softkey.
- Using the rotary knob or the cursor keys, select BNC I/O MODE... and confirm your choice with the ENTER key or the HARDWARE SETUP softkey.
- Using the rotary knob or the cursor keys, select TS-ASI OUT and confirm your choice with the ENTER key or the HARDWARE SETUP softkey.

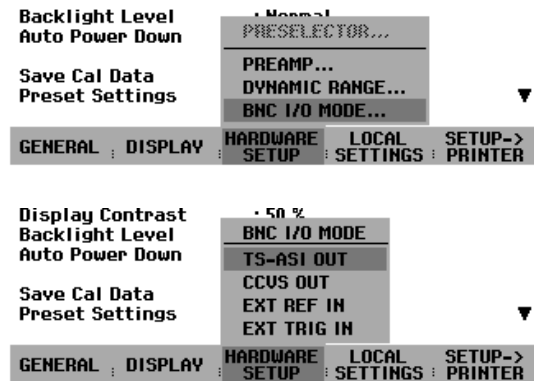

## Measurement Parameter List

The measurement parameter list provides an overview of the important instrument settings, the received signal status and the quality of the received digital TV signal.

### Instrument Settings

The instrument settings that are shown are dependent on the selected standard.

Instrument Settings	Explanation
<b>Standard</b>	The selected digital TV standard is displayed. You can select the standard in the SETUP – LOCAL SETTINGS – DIGITAL TV menu.
<b>Center frequency</b>	The center frequency you have selected is displayed. With the 8VSB/ATSC standard, the center frequency which you last entered is displayed. Otherwise, the 8VSB pilot frequency is displayed. The frequency is entered in the FREQ menu.
<b>8VSB pilot frequency</b>	With the 8VSB/ATSC standard, the 8VSB pilot frequency which you last entered is displayed. Otherwise, the center frequency is displayed. The frequency is entered in the FREQ menu.
<b>Channel</b>	The channel number and information about the selected channel are displayed. A display also occurs in the center frequency or 8VSB pilot setting but only if the set frequency matches a channel in the selected channel table. A frequency offset of up to 40 kHz is tolerated. The channel and the selection for the channel table are entered in the FREQ menu.
<b>Modulation</b>	The set modulation is displayed, e.g. 64QAM. Settings are made in the BW – QAM ORDER menu.
<b>Symbol rate</b>	The symbol rate you have selected is displayed. Settings are made in the BW – SYMBOL RATE menu.
<b>Reference level</b>	<p>The reference level you have selected is displayed.</p> <p>To the right of the reference level, the difference with respect to the ideal demodulator level is displayed in parentheses as an aid in setting the reference level. If the difference is too large, TOO LOW or TOO HIGH is displayed. You should then change the reference level setting accordingly.</p> <p>To simplify operation and to avoid incorrect measurements, the R&amp;S FSH3-TV is equipped with an automatic routine (LEVEL ADJUST) for setting the optimum reference level. In the Measurement List operating mode, the setting criterion for the LEVEL ADJUST function is the modulation error of the demodulated TV signal.</p>

## Measurement Parameters

The measurement parameters that are shown are dependent on the selected standard.

Measurement parameter	Explanation
<b>Power</b>	The power or the level of the received TV signal is displayed using the set unit.
<b>Carrier frequency offset</b>	The carrier frequency offset represents the frequency offset between the received digital TV signal and the frequency setting.
<b>Symbol rate offset</b>	The symbol rate offset represents the frequency offset between the measured symbol rate of the received TV signal and the set symbol rate.
<b>FEC decoder</b>	The status of the Reed-Solomon decoder is displayed. <b>LOCKED:</b> The Reed-Solomon decoder is locked.  <b>UNLOCKED:</b> The Reed-Solomon decoder is unlocked.
<b>Modulation error ratio</b>	The modulation error of the demodulated IQ components is displayed with respect to the RMS value of the carrier power. The ratio is displayed in % and dB. To compute the modulation error ratio, 10000 symbols are used. The measured value is updated whenever 1000 symbols have been analyzed. A clock symbol is displayed after the measurement parameter until 10000 symbols are available for the computation.
<b>Error vector magnitude</b>	The vector error of the demodulated IQ components is displayed with respect to the peak power. The ratio is displayed in % and dB. To compute the vector error ratio, 10000 symbols are used. The measured value is updated whenever 1000 symbols have been analyzed. A clock symbol is displayed after the measurement parameter until 10000 symbols are available for the computation.
<b>BER before RS decoder</b>	The bit error ratio representing the errored bits with respect to the transmitted bits as detected prior to the error correction equipment (Reed-Solomon decoder) is displayed. To measure the bit error ratio (BER), the R&S FSH3-TV uses a sliding computation, i.e. it automatically determines the required number of data samples to compute the bit error ratio as a function of the measured error rate. In case of error-free data streams, the number of samples used to compute the BER is continuously increased. The number of samples used in the computation is indicated after the measured value for the BER. The second number indicates how many samples are required to make the measurement given the current resolution of the measurement result. If this number is reached, the resolution of the BER measured value result is increased by one power of ten. For example, the indication (1K33/10K0) means that the computation of the current BER measured value used the 1330 samples. For 10000 samples, the resolution of the BER measurement result is increased by one power of ten. If errors occur in the transmission chain, only the required samples are used for the BER computation. Then, the resolution of the BER measured value result is no longer increased or decreased.

Measurement parameter	Explanation
<b>Packet error ratio</b>	The packet error ratio (PER) is displayed for the DVB-C standards J.83/A (Europe Cable) and J.83/C (Japanese Cable). The packet error ratio is the ratio of the errored, uncorrected MPEG frames with respect to the transmitted MPEG frames in the Reed-Solomon output data stream.  For the PER computation, the same principle is used as for the BER computation.
<b>Segment error ratio</b>	The segment error ratio (SER) is displayed for the DVB-C standard J.83/B (US Cable) and for the terrestrial transmission standard 8VSB/ATSC. The segment error ratio is the ratio of the errored, uncorrected segments with respect to the transmitted segments in the Reed-Solomon output data stream.  For the SER computation, the same principle is used as for the BER computation.
<b>Transport stream rate</b>	The transmission rate of the transport stream at the output of the Reed-Solomon decoder is displayed.

### Switching on the Measurement Parameter List

Switching on the measurement parameter list if the digital TV receiver is already activated:

- Press the MEAS key until the F1 function key displays SELECT MEASURE.
- Press the SELECT MEASURE softkey.
- Using the rotary knob or the cursor keys, select MEASUREMENT LIST and confirm your choice with the ENTER key or the SELECT MEASURE softkey.



Switching on the measurement parameter list if another measurement mode besides the digital TV receiver is already activated:

- Press the MEAS key until the F1 function key displays MEASURE.
- Using the rotary knob or the cursor keys, select DIGITAL TV RECEIVER and confirm your choice with the ENTER key or the MEASURE softkey.
- Using the rotary knob or the cursor keys, select MEASUREMENT LIST and confirm your choice with the ENTER key or the SELECT MEASURE softkey.

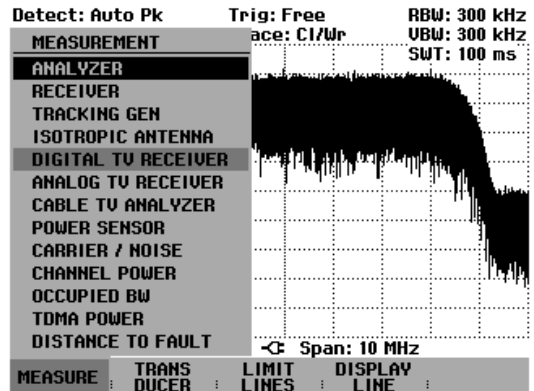

The measurement parameter list should appear in the display.  
The function keys for the menus should be switched.

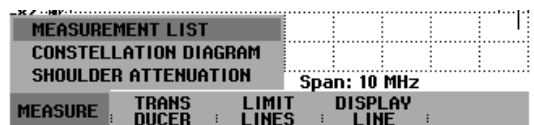



## **Level Adjust**

To simplify operation and to prevent incorrect measurements, the R&S FSH3-TV has an automatic routine for setting the reference level. In the Parameter List operating mode, the LEVEL ADJUST function measures the modulation error of the demodulated signal as a function of the reference level. Then, the reference level is set at which the lowest modulation error was measured. This ensures that the receiver is optimally set, irrespective of the channels and levels of the input signal.

## **Restart Measure**

Resetting the demodulator causes a restart of the synchronization routine. All of the measurements are reset.

- Press the MEAS key until the F1 function key displays SELECT MEASURE.
- Press the RESTART MEASURE key.

## **Selecting the Unit for Power Measurement of the Digital TV Signal**

The power of the digital TV channel can be measured in dBm, dBmV or dB $\mu$ V.

- Press the MEAS key until the F1 function key displays SELECT MEASURE.
- Press the PWR UNIT softkey.
- Using the rotary knob or the cursor keys, select the unit you want and confirm your choice with the ENTER key or the PWR UNIT softkey.

## Constellation Diagram

In the Constellation Diagram operating mode, the R&S FSH3-TV represents the complex baseband signal using a Cartesian coordinate system. The in-phase component corresponds to the abscissa and the quadrature component to the ordinate. The representation takes place only at the sampling instant. In addition to the constellation diagram, the same parameters of the measurement parameter list are displayed.

### Screen Layout

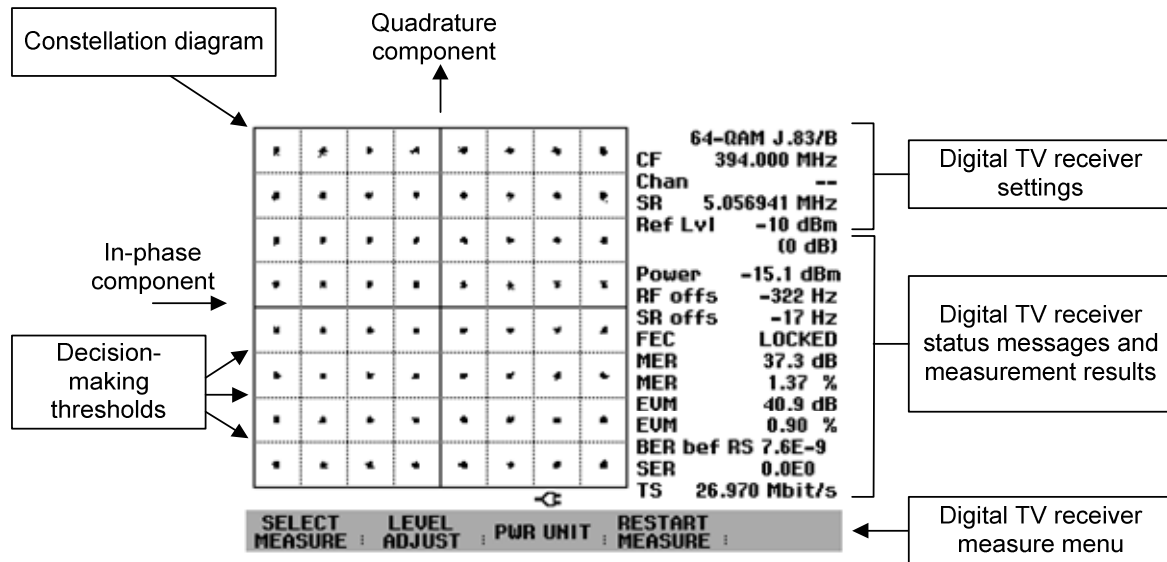

### Parameters

In the Constellation Diagram operating mode, in addition to the constellation diagram the same parameters are shown as in the Measurement List operating mode. To save space, abbreviations are used for the parameter names.

Status message or measurement parameter	Abbreviation used in the constellation diagram
Standard	An abbreviated version of the standard name appears.
Center frequency	CF
8VSB pilot frequency	PF
Channel	Chan
Modulation	The modulation is contained in the standard name and is not displayed.
Symbol rate	SR
Reference level	Ref Lvl
Power	Power
Carrier frequency offset	RF Offs
Symbol rate offset	SR Offs
FEC decoder	FEC

Modulation error ratio	MER
Error vector magnitude	EVM
BER before RS decoder	BER bef RS
Packet error ratio	PER
Segment error ratio	SER
Transport stream rate	TS

### Switching on the Constellation Diagram Operating Mode

Switching on the constellation diagram if the digital TV receiver is already activated:

- Press the MEAS key until the F1 function key displays SELECT MEASURE.
- Press the SELECT MEASURE softkey.
- Using the rotary knob or the cursor keys, select CONSTELLATION DIAGRAM and confirm your choice with the ENTER key or the SELECT MEASURE softkey.

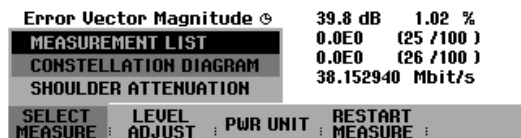

Switching on the constellation diagram if another measurement mode besides the digital TV receiver is already activated:

- Press the MEAS key until the F1 function key displays MEASURE.
- Using the rotary knob or the cursor keys, select DIGITAL TV RECEIVER and confirm your choice with the ENTER key or the MEASURE softkey.
- Using the rotary knob or the cursor keys, select CONSTELLATION DIAGRAM and confirm your choice with the ENTER key or the SELECT MEASURE softkey.

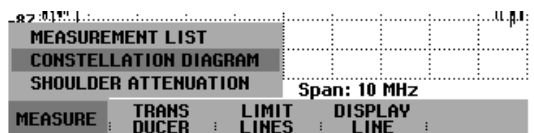
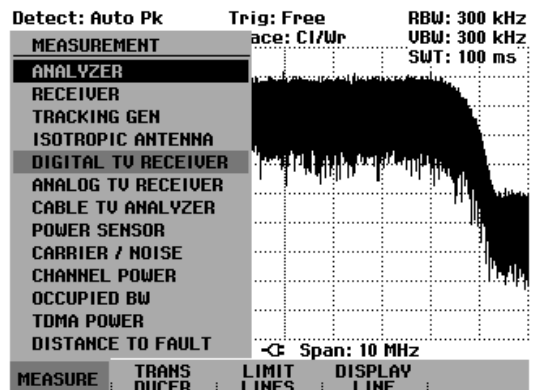

The measurement screen for the constellation diagram should appear in the display. The function keys for the menus should be switched.

## Level Adjust

To simplify operation and to prevent incorrect measurements, the R&S FSH3-TV has an automatic routine for setting the reference level. In the Constellation Diagram operating mode, the LEVEL ADJUST function measures the modulation error of the demodulated signal as a function of the reference level. Then, the reference level is set at which the lowest modulation error was measured. This ensures that the receiver is optimally set, irrespective of the channels and levels of the input signal.

## Restart Measure

Resetting the demodulator causes a restart of the synchronization routine. All of the measurements are reset.

- Press the MEAS key until the F1 function key displays SELECT MEASURE.
- Press the RESTART MEASURE key.

## Selecting the Unit for Power Measurement of the Digital TV Signal

The power of the digital TV channel can be measured in dBm, dBmV or dB $\mu$ V.

- Press the MEAS key until the F1 function key displays SELECT MEASURE.
- Press the PWR UNIT softkey.
- Using the rotary knob or the cursor keys, select the unit you want and confirm your choice with the ENTER key or the PWR UNIT softkey.

## Trace Functions

The IQ constellation can be analyzed in a number of different ways:

- CONT  
The R&S FSH3-TV displays the currently demodulated I/Q symbols. The number of the symbols can be set from 1000 to 1000000 symbols in steps of 1000 symbols. In the default setting, 10000 symbols are used. The screen is updated at intervals of 1000 symbols. A clock symbol is displayed below the constellation diagram until the requested number of symbols can be displayed. When activated, the IQ symbol memory is cleared, i.e. the screen is totally regenerated. If there is no synchronization to the received signal, 1000 symbols are displayed. CONT is the default setting.
- HOLD  
The R&S FSH3-TV adds up the IQ symbols. It does not interrupt this procedure until another setting has been chosen. When activated, the IQ symbol memory is cleared, i.e. the screen is totally regenerated.
- VIEW  
The R&S FSH3-TV freezes the currently displayed constellation diagram.

**Operating sequence:**

- Press the TRACE key.
- Press the softkey for the desired trace mode.

Setting the symbol counter in CONT mode:

- Press the TRACE key.
- Press the SYMBOL COUNT softkey.

The R&S FSH3-TV opens the entry field for setting the symbol counter. The following actions can be performed:

- Confirm the displayed number of symbols with the SYMBOL COUNT softkey or the ENTER key.
- Using the numeric keypad, enter a new figure between 1000 and 1000000 for the number of symbols and confirm your entry with the SYMBOL COUNT softkey or the ENTER key.
- Use the rotary knob to change the number of symbols in steps of 1000 symbols.
- Use the cursor keys to change the number of symbols in steps of 10000 symbols.

*Note:* You can set the symbol counter only in the TRACE CONT operating mode.

In the VIEW trace mode, the settings used for measuring the trace are displayed. This ensures that the measurement conditions are clearly specified in result documentation. In the status display (STATUS key), an indication is made in parentheses that the view mode is currently selected, e.g. Trace Mode: Hold (View).

f				←				→				↵				64-QAM J.83/A			
•				•				•				•				CF 1000.000 MHz			
•				•				•				•				Chan --			
•				•				•				•				SR 6.900000 MHz			
•				•				•				•				Ref Lvl -15 dBm (0 dB)			
•				•				•				•				Power -15.1 dBm			
•				•				•				•				RF offs -31 Hz			
•				•				•				•				SR offs 0 Hz			
•				•				•				•				FEC LOCKED			
•				•				•				•				MER 37.7 dB			
•				•				•				•				MER 1.31 dB			
•				•				•				•				EUM 41.4 dB			
•				•				•				•				EUM 0.86 %			
•				•				•				•				BER bef RS 0.0E0			
•				•				•				•				PER 0.0E0			
SC: 10000																			
CONT				HOLD				VIEW				SYMBOL COUNT							

## Measuring the Shoulder Attenuation

In Shoulder Attenuation mode, the R&S FSH3-TV measures the shoulder attenuation of the received digital TV signal. With the QAM standards, it makes measurements in accordance with ETSI TR 101 290, and with the 8VSB/ATSC standard in accordance with the FCC recommendation.

*Note:* The TS-ASI signal is not available in the Shoulder Attenuation operating mode.

### Shoulder Attenuation Measurement in Compliance with ETSI TR 101 290

With the QAM standards, the R&S FSH3-TV measures the shoulder attenuation in compliance with ETSI TR 101 290.

The shoulder attenuation in compliance with TR 101 290 indicates the power separation between the maximum power of the QAM signal and the spurious emissions above and below the useful channel. The measurements of the maximum power and the undesired spurious emissions are made with the same measurement bandwidth.

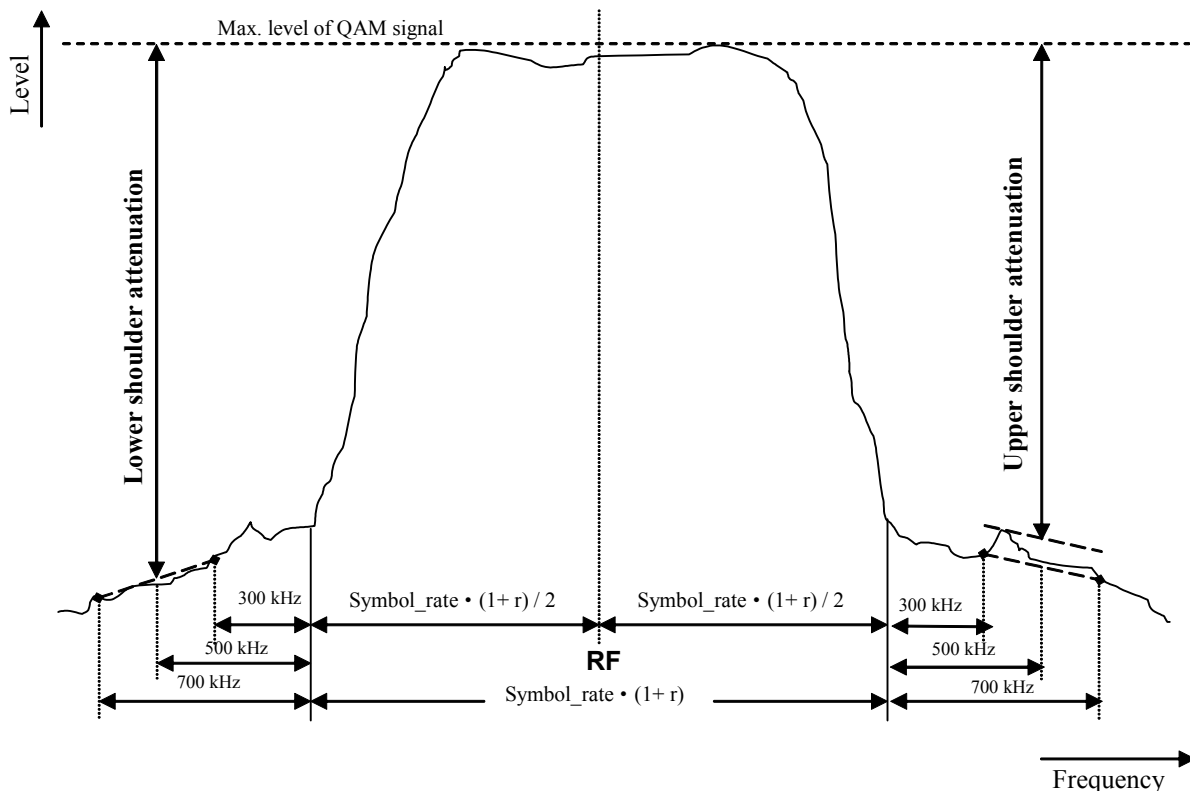

In compliance with the recommendation in the document ETSI TR 101 290, measurement of the shoulder attenuation involves multiple steps.

1. Search for the maximum power of the QAM signal within the transmission channel.
2. Power measurement of the spurious emission 300 kHz and 700 kHz above and below the QAM transmission channel.
3. Draw a straight line through the two points measured at a spacing of 300 kHz and 700 kHz above or below the useful signal.
4. Parallel shifting of this line until it intersects the maximum which occurs in the frequency range from 300 kHz to 700 kHz above or below the QAM signal.

5. Computation of the level at a spacing of 500 kHz above (upper shoulder) and below (lower shoulder) the QAM spectrum by solving the equation for the straight line.
6. The power ratio of the maximum power given under item 1 and the power computed under item 5 yields the values for the upper shoulder attenuation and the lower shoulder attenuation in compliance with ETSI TR 101 290.

The frequency ranges for determining the spurious emissions are determined automatically and are linked to the set symbol rate and the roll-off factor r (which is dependent on the standard which is selected).

### Shoulder Attenuation Measurement for 8VSB Signals in Compliance with the FCC Recommendation

With the 8VSB/ATSC standard, the R&S FSH3-TV measures the shoulder attenuation in compliance with the FCC recommendation.

According to the FCC, the spurious emissions in the adjacent channels in the first 500 kHz of the adjacent channel must be less than -47 dB referred to the total power of the useful channel. Starting at a frequency spacing  $\Delta f$  of 500 kHz from the channel limit, the spurious emissions must decrease in compliance with the following formula:

$$\text{Attenuation / dB} = -11.5 (\Delta f + 3.6)$$

Where  $\Delta f$  is the frequency spacing from the channel limit in MHz.

In order to measure the spurious emission, you must take into account the RMS value referred to a bandwidth of 500 kHz. The shoulder attenuation is the power ratio of the overall useful channel power including the pilot signal to the RMS power of the first 500 kHz in the adjacent channel. It is necessary to distinguish between the shoulder attenuation in the upper and lower adjacent channels. According to the FCC, the spurious emission can be measured with a bandwidth that is less than 500 kHz. However, the result must be converted to a bandwidth of 500 kHz in order to compute the shoulder attenuation.

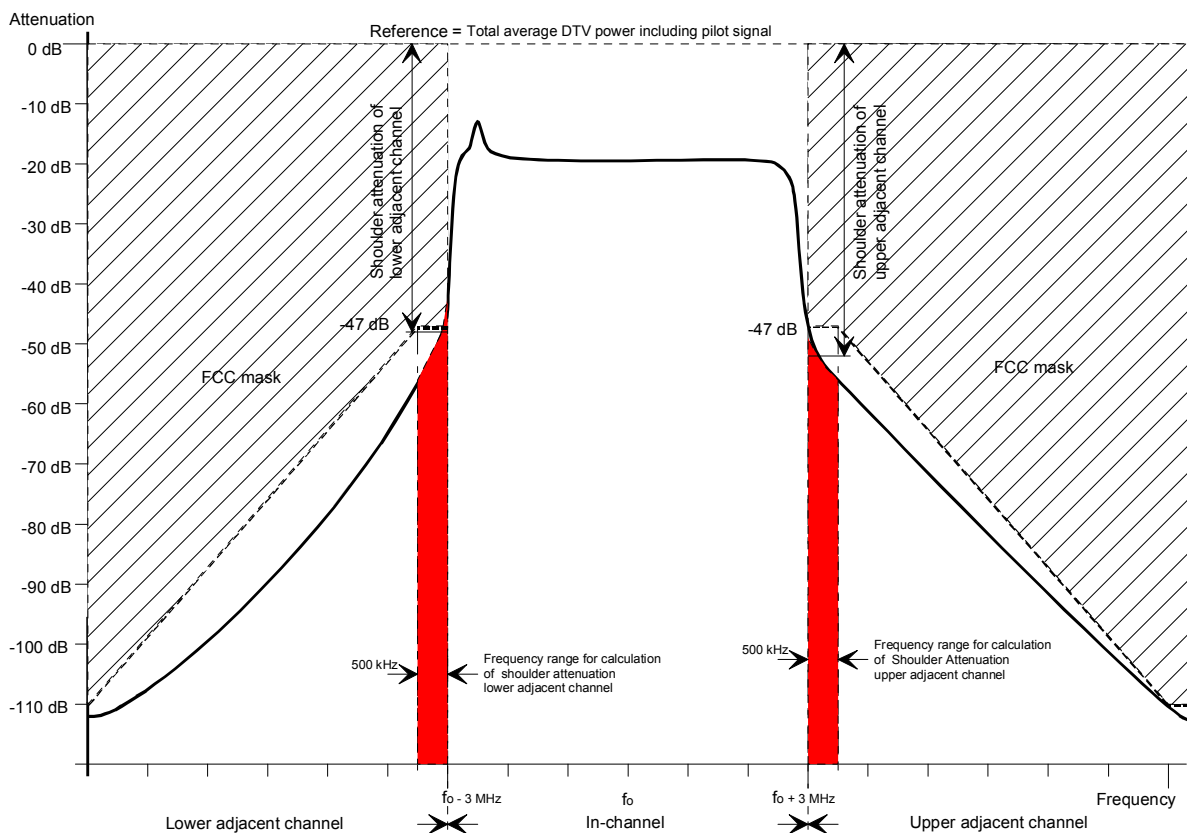

Screen Layout

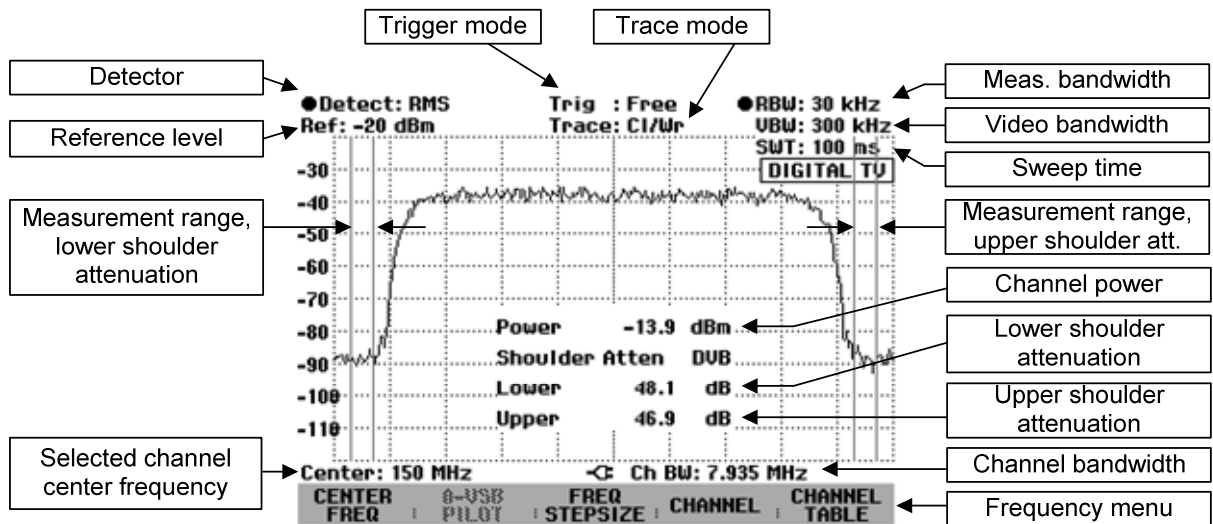

Switching on the Shoulder Attenuation Operating Mode

Switching on the shoulder attenuation measurement if the digital TV receiver is already activated:

- Press the MEAS key until the F1 function key displays SELECT MEASURE.
- Press the SELECT MEASURE softkey.
- Using the rotary knob or the cursor keys, select SHOULDER ATTENUATION and confirm your choice with the ENTER key or the SELECT MEASURE softkey.

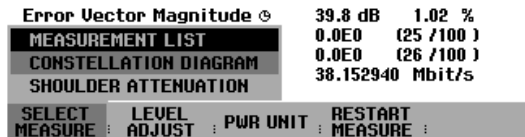

Switching on the shoulder attenuation measurement if another measurement mode besides the digital TV receiver is already activated:

- Press the MEAS key until the F1 function key displays MEASURE.
- Using the rotary knob or the cursor keys, select DIGITAL TV RECEIVER and confirm your choice with the ENTER key or the MEASURE softkey.
- Using the rotary knob or the cursor keys, select SHOULDER ATTENUATION and confirm your choice with the ENTER key or the SELECT MEASURE softkey.

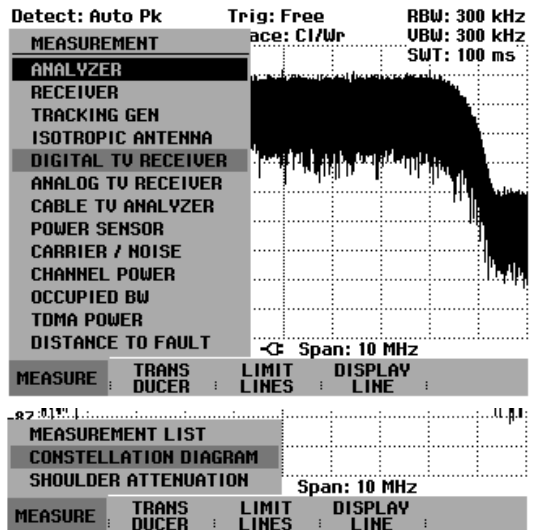

The measurement screen for the constellation diagram should appear in the display.



The measurement screen for the shoulder attenuation measurement should appear in the display. The function keys for the menus should be switched. When shoulder attenuation operating mode is launched, the instrument settings for measuring the shoulder attenuation are set to their default values.

### Level Adjust

To simplify operation and to prevent incorrect measurements, the R&S FSH3-TV has an automatic routine for setting the reference level. In the Shoulder Attenuation operating mode, the LEVEL ADJUST function measures the shoulder attenuation depending on the reference level. Then, the reference level is set at which the greatest shoulder attenuation was measured. This ensures that the receiver is optimally set, irrespective of the channels and levels of the input signal.

The Level Adjust routine can be used either on the upper or the lower shoulder.

*Note: The Level Adjust routine assumes that the shoulder frequency range is unoccupied. The shoulder frequency ranges are indicated with blue frequency lines in the measurement screen.*

- Pressed the key until the softkey labeling for the digital TV receiver main menu appears.
- Press the LEVEL softkey.
- Using the rotary knob or the cursor keys, select the routine you want and confirm your choice with the ENTER key or the LEVEL softkey.

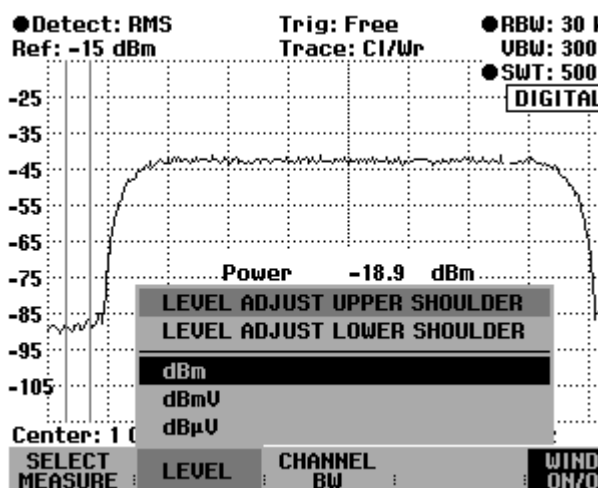

### Setting the Unit for the Measured Channel Power

The measured channel power can be displayed in either dBm, dBmV or dBµV.

- Pressed the MEAS key until the softkey labeling for the digital TV receiver main menu appears.
- Press the LEVEL softkey.
- Using the rotary knob or the cursor keys, select the unit you want and confirm your choice with the ENTER key or the LEVEL softkey.

## Displaying the Shoulder Attenuation Parameters

In Shoulder Attenuation operating mode, the R&S FSH3-TV displays the channel power and the upper and the lower shoulder attenuation at the bottom of the measurement diagram. Usually this does not obscure the trace. However, if the trace is in this area of the screen, the display can be blanked out. Simply press the WINDOW ON/OFF key. If the softkey is highlighted in green, the display is on.

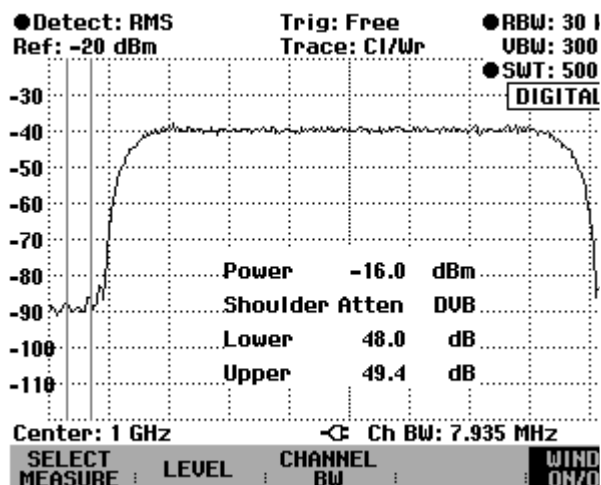

## Setting the Channel Bandwidth

In the default setting, the R&S FSH3-TV automatically sets the channel bandwidth. With the QAM standards, it calculates the channel bandwidth from the standard-dependent roll-off factor and the set symbol rate.

$$\text{Channel bandwidth} = \text{symbol rate} * (1 + \text{roll-off factor})$$

With the 8VSB/ATSC standard, the channel bandwidth is set to 6 MHz during automatic setting.

You can also set the channel bandwidth manually instead of using the automatic setting. This allows you to also measure the shoulder attenuation values of carrier signals where the power is equally distributed, e.g. DVB-T signals with OFDM modulation.

### Setting the channel bandwidth manually:

- Pressed the MEAS key until the softkey labeling for the digital TV receiver main menu appears.
- Press the CHANNEL BW softkey.
- Using the rotary knob or the cursor keys, select MANUAL... and confirm your choice with the ENTER key or the CHANNEL BW softkey.

The R&S FSH3-TV opens the entry field for setting the channel bandwidth.

- Use the rotary knob, the cursor keys or a numerical entry to set or change the channel bandwidth.

## Setting the Resolution Bandwidth

In the default setting, the R&S FSH3-TV automatically sets the resolution bandwidth depending on the frequency span. You can also set the resolution bandwidth manually instead of using the automatic setting. Your choice of the resolution bandwidth will influence the noise display. If the bandwidth is small, the noise displayed drops. If the bandwidth is reduced or increased by a factor of 3, the noise displayed drops or goes up by 5 dB. If the bandwidth is changed by a factor of 10, the displayed noise changes by 10 dB. The resolution bandwidth which is selected also has an effect on the sweep speed. If the true spectrum is to be displayed, the band filters that determine the resolution bandwidth must settle at all frequencies of interest. Narrow band filters take longer to settle than wide filters. This is why a longer sweep time must be selected for narrow resolution bandwidths. If the bandwidth is reduced by a factor of 3 (e.g. from 10 kHz to 3 kHz), the sweep time must be increased by a factor of 9. If the reduction factor is 10 (e.g. from 10 kHz to 1 kHz), the sweep time must be increased by a factor of 100.

### Setting the resolution bandwidth manually:

- Press the BW key.
- Press the MANUAL RES BW softkey.

The R&S FSH3-TV opens the entry field for setting the resolution bandwidth.

- Use the rotary knob, the cursor keys or a numerical entry to set or change the resolution bandwidth.

## Setting the Video Bandwidth

The video filter is a lowpass filter that smoothes out the measurement trace. In the default setting, the R&S FSH3-TV automatically sets the video bandwidth depending on the resolution bandwidth and the detector. You can also set the video bandwidth manually instead of using the automatic setting. Like the resolution bandwidth, the video bandwidth has an effect on sweep speed. The spectrum analyzer must pause before each measurement to allow the video filter to settle.

### Setting the video bandwidth manually:

- Press the BW key.
- Press the MANUAL VIDEO BW softkey.

The R&S FSH3-TV opens the entry field for setting the video bandwidth.

- Use the rotary knob, the cursor keys or a numerical entry to set or change the video bandwidth.

## Setting the Detector

In the default setting for shoulder attenuation measurement, the RMS detector is selected. The user can manually select the detector.

### Operating sequence:

- Press the TRACE key.
- Press the DETECTOR softkey.
- Using the rotary knob or the cursor keys, select the detector you want and confirm your choice with the ENTER key or the DETECTOR softkey.

## Trace Functions

A variety of display modes can be selected for the trace:

- CLEAR/WRITE                      The R&S FSH3-TV clears the old trace during a new sweep. This is the default setting.
- AVERAGE                          The R&S FSH3-TV computes the average value of the level based on consecutive measured traces. In the default setting, averaging is on a pixel-by-pixel basis and is sliding over the ten previous traces. Alternatively, you can set the number for the averaging from 2 to 999. This reduces the effects of noise, for example, but has no effect on discrete interference.
- MAX HOLD                          The trace indicates the maximum value that has been measured up to that point in time. The R&S FSH3-TV interrupts the Max Hold mode only if another setting is selected and the trace pixels from the new setting cannot be compared with the trace pixels from the previous setting – for example if the span is changed. Intermittent signals in the spectrum or the maximum of fluctuating signals are easy to find with MAX HOLD.
- MIN HOLD                          The trace indicates the minimum value that has been measured up to that point in time. The R&S FSH3-TV interrupts the Min Hold mode only if another setting is selected and the trace pixels from the new setting cannot be compared with the trace pixels from the previous setting – for example if the span or the center frequency is changed. With MIN HOLD, sine signals within the noise can be highlighted or intermittent signals suppressed.
- VIEW                                  The R&S FSH3-TV freezes the currently displayed trace. The measurement is aborted. This, for instance, allows subsequent evaluation of spectra with the aid of the marker.

**Operating sequence:**

- Press the TRACE key.
- Press the softkey for the desired trace mode.

**Setting the averaging factor:**

- Press the TRACE key.
- Press the TRACE MODE softkey.
- Using the rotary knob or the cursor keys, select AVERAGE and confirm your choice with the ENTER key or the TRACE MODE softkey.

The R&S FSH3-TV opens the entry field for setting the averaging factor. The following actions can be performed:

- Confirm the displayed averaging factor with the TRACE MODE softkey or the ENTER key.
- Use the numerical keypad to enter an averaging factor between 2 and 999 and confirm your choice with the TRACE MODE softkey or the ENTER key.
- Use the rotary knob to change the averaging factor in single steps.

Use the cursor keys to change the averaging factor in steps of 10.

In the status display (STATUS key), it is indicated in brackets that the view mode is currently selected, e.g. Trace Mode: AVERAGE (View).

## Measurements with the Cable TV Analyzer

Intermodulation products arise in cable TV systems due to nonlinear distortion. To allow measurement of composite triple beat (CTB) intermodulation products and composite second order (CSO) intermodulation products, the R&S FSH3-TV can perform CTB and CSO measurements in the CABLE TV ANALYZER menu.

The R&S FSH3-TV carries out the measurement in compliance with the EN 50083 standard in two steps. First, the reference power is measured or a reference power is determined which is then used to calculate the CTB or CSO ratio. In the second step, the instrument measures the power of the CTB or CSO intermodulation products in an unoccupied transmission channel and calculates their ratio to the reference power.

### Activating the CTB or CSO Measurement

- Press the MEAS key until the F1 function key displays MEASURE.
- Press the MEASURE softkey.
- Using the cursor keys or the rotary knob, select CABLE TV ANALYZER from the menu and confirm your choice with the ENTER key or the MEASURE softkey.
- Using the cursor keys or the rotary knob, select CTB or CSO measurement from the menu and confirm your choice with the ENTER key or the MEASURE softkey.

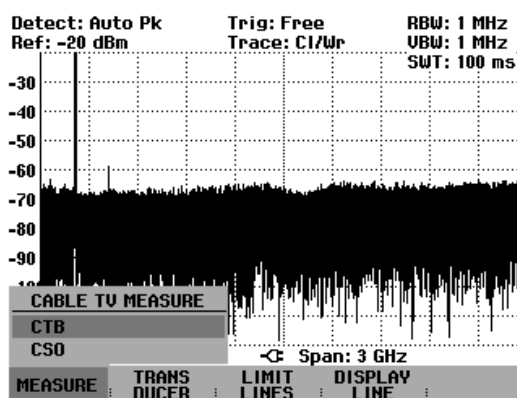

The R&S FSH3-TV activates the desired measurement mode and starts the reference measurement. To indicate that the reference measurement has been activated, the REF MEASURE softkey is highlighted in green.

## Determining the Reference

Before you can determine the CTB or CSO ratio, it is necessary to determine the reference power or the reference level. The R&S FSH3-TV offers two ways to determine the reference: Measurement of the vision carrier power and manual entry of the reference. The reference is the peak power of the vision carrier.

### Screen Layout for the Reference Measurement

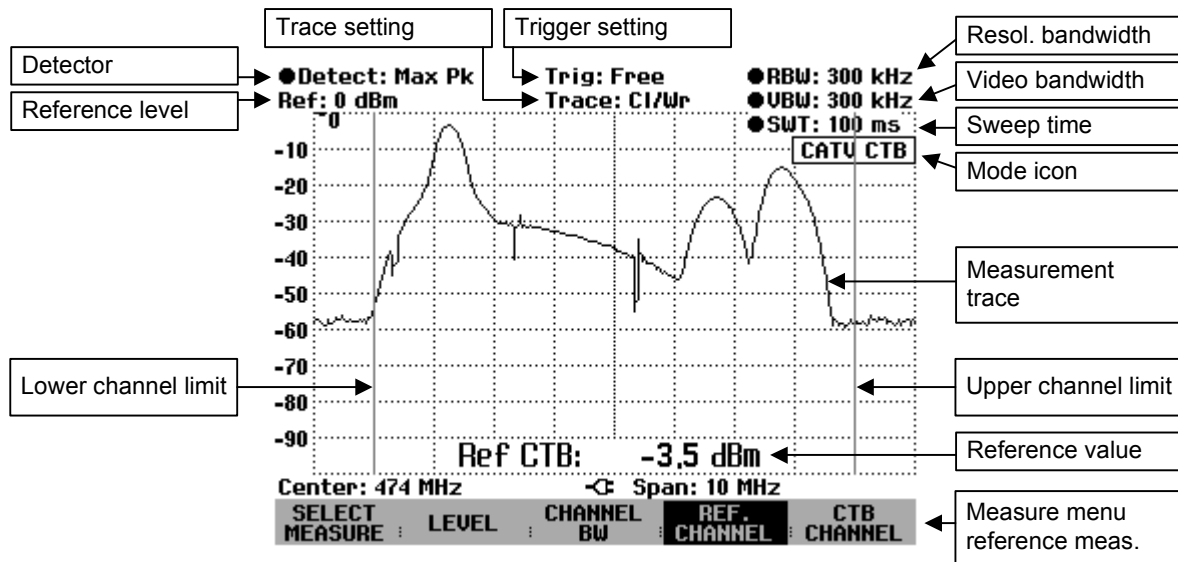

### Setting the Channel Bandwidth

- Press the MEASURE softkey until the measurement menu for the CATV analyzer appears.
- Press the CHANNEL BW softkey.
- Using the rotary knob or the cursor keys, change the channel bandwidth or use the numeric keypad to enter a new channel bandwidth and confirm your choice with the ENTER key or the CHANNEL BW softkey.

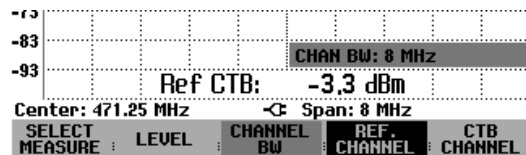

*Note:* You should make this setting prior to setting the frequency since the vision carrier frequency and the channel center frequency are dependent on the channel bandwidth and are computed accordingly (see below).

## Setting the Reference Channel

You can set the reference channel by entering the channel number for a loaded channel table, the vision carrier frequency or the channel center frequency.

When entering the channel center frequency, the R&S FSH3-TV computes the vision carrier frequency as a function of the set channel bandwidth and the sideband setting.

Upper sideband: Vision carrier frequency = channel center frequency – channel bandwidth / 2 + 1.25 MHz

Lower sideband: Vision carrier frequency = channel center frequency + channel bandwidth / 2 - 1.25 MHz

*Note: The sideband is set in the BW menu. In the default setting, the R&S FSH3-TV automatically sets the proper sideband depending on the analog TV standard which is selected.*

When you enter the channel number, the R&S FSH3-TV computes the vision carrier frequency. It assumes that the channel center frequency is entered in the channel table. This is true for the supplied TV channel tables with the R&S FSH VIEW software and must be taken into account when creating channel tables.

- Press the MEASURE softkey until the measurement menu for the CATV analyzer appears.
- Press the REF MEASURE softkey.
- Using the cursor keys or the rotary knob, select CHANNEL, VISION CARR FREQ or CHANNEL CTR FREQ from the menu and confirm your choice with the ENTER key or the REF MEASURE softkey.

The appropriate input box should open. There are the following possibilities:

- Use the rotary knob or the cursor keys to change the frequency or the channel.
- Use the numerical keypad to enter a new frequency or channel and confirm your input with the ENTER key or the REF MEASURE softkey.
- Confirm the displayed frequency or channel with the ENTER key or the REF MEASURE softkey.

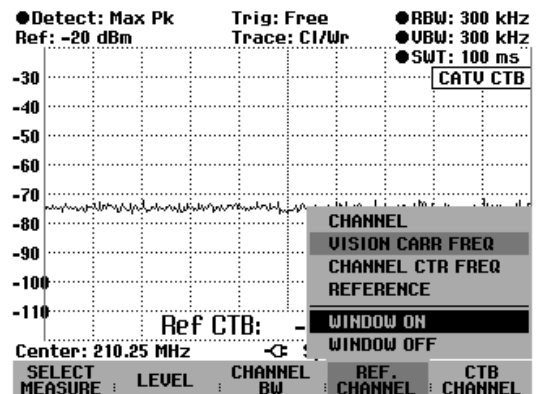

The R&S FSH3-TV performs the reference measurement in the selected receive channel. It measures the maximum power or maximum level within the receive channel, interprets it as the reference and shows it at the bottom of the display. The channel limits are indicated with blue display lines.



## Setting the Reference Level

The setting for the reference level determines the drive conditions for the receiver. Manual settings are made in the AMPT menu.

- Press the **FREQ** key.
- Change the reference level setting with the cursor keys or the rotary knob, or enter a new reference level via the numeric keypad. Press the **LEVEL** softkey.

To simplify operation and to avoid wrong settings, the R&S FSH3-TV is equipped with an automatic routine for setting the reference level. During the reference measurement, the **LEVEL ADJUST** function measures the level at the input mixer and sets the reference level accordingly.

- Press the **MEASURE** softkey until the measurement menu for the CATV analyzer appears.
- Press the **LEVEL** softkey.
- Confirm the **LEVEL ADJUST** setting with the **ENTER** key.

The R&S FSH3-TV will display an appropriate message on the screen while it is determining the optimum reference level setting.

## Measuring the Reference for Vision Carriers with Negative Modulation

The vision carrier has negative modulation in the B, G, H, I, D, K, M and N standards. The maximum vision carrier power occurs at the instant of the sync pulse.

The default settings for the frequency display range (span), resolution bandwidth, video bandwidth and sweep time have been optimized. If you want to change the settings, note the following:

- The span is preset to the channel bandwidth of the reference channel. When changes are made to the channel bandwidth, the R&S FSH3-TV automatically sets the appropriate span.
- The resolution bandwidth (RBW) should be at least 300 kHz to ensure that the peak power of the vision carrier is measured.
- The peak detector is recommended. It ensures that the peak power of the vision carrier is correctly measured.
- The video bandwidth (VBW) must be at least as wide as the resolution bandwidth. This prevents incorrect power measurement results due to the compression of signal peaks by the video filter. In the default setting, the R&S FSH3-TV automatically sets the optimum video bandwidth.
- The sweep time is coupled to the span, resolution bandwidth and video bandwidth. Set the sweep time in such a way that the filters can settle. Too short a sweep time distorts the measurement result. In the default setting, the R&S FSH3-TV automatically sets the optimum sweep time.

The R&S FSH3-TV displays the measurement result at the bottom center of the screen. The measurement result is updated after each sweep.

## Measuring the Reference for Vision Carriers with Positive Modulation

In the L standard, the vision carrier has positive modulation, i.e. the peak power occurs only for white modulation. White modulation occurs reliably only in the test lines which are transmitted in the vertical blanking interval. Using the settings described below, the R&S FSH3-TV can reliably measure the peak power.

- Set the display range (span) to Zero Span.
  - Press the SPAN key.
  - Press the ZERO SPAN softkey.

The R&S FSH3-TV will automatically set the receive frequency to the vision carrier frequency. It will make the computation based on the selected channel bandwidth and analog TV standard.
- Set the resolution bandwidth to 300 kHz.
  - Press the BW key.
  - Use the rotary knob, the cursor keys or the numerical keypad to set the resolution bandwidth to 300 kHz.
- Set the video bandwidth to 3 MHz.
  - Press the BW key.
  - Press the MANUAL VIDEO BW softkey.
  - Use the rotary knob, the cursor keys or the numerical keypad to set the video bandwidth to 3 MHz.
- Set to sweep time to 50 ms.
  - Press the SWEEP key.
  - Use the rotary knob, the cursor keys or the numerical keypad to set the sweep time to 50 ms.
  - Select the RMS detector.
  - Press the TRACE key.
  - Press the DETECTOR softkey.
  - Use the rotary knob or the cursor keys to select RMS and confirm your entry with the ENTER key.

The R&S FSH3-TV displays the measurement result at the bottom center of the screen. The measurement result is updated after each sweep.

### Averaging of Measured Values

In order to determine the reference, individual measurement result can be averaged. In the default setting, averaging is sliding over the ten previous measured values. Alternatively, you can set the number for the averaging from 2 to 999. This helps, for example, to suppress noise.

- Press the TRACE key.
- Press the TRACE MODE softkey.
- Use the rotary knob or the cursor keys to select AVERAGE and confirm your entry with the ENTER key.

The AVG COUNT input field will open to display the selected number of averagings.

The following actions can be performed:

- Confirm the displayed number of averagings with the TRACE softkey or the ENTER key.
- Using the numeric keypad, enter a new number between 2 and 999 for the number of averagings and confirm your entry with the TRACE softkey or the ENTER key.
- Change the number of averagings with the rotary knob or the cursor keys.

The R&S FSH3-TV averages the measured values over the set number of averagings.

If the sweep is continuous, the instrument then performs a sliding averaging. In SINGLE SWEEP mode, it performs exactly those sweeps defined with AVG COUNT and averages the measured values. It then stops the sweep and displays the average measured value.

### Manually Determining the Reference

As an alternative to the reference measurement, you can specify the reference.

- Press the MEASURE softkey until the measurement menu for the CATV analyzer appears.
- Press the REF MEASURE softkey.
- Using the rotary knob or the cursor keys, select the REFERENCE and confirm your choice with the ENTER key or the LEVEL softkey.

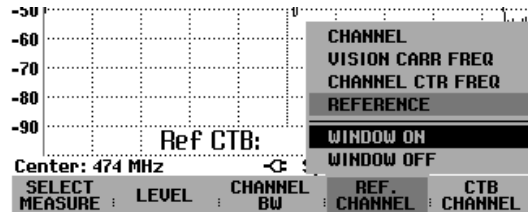

The R&S FSH3-TV opens the entry field for setting the reference.

- Using the rotary knob or the cursor keys, change the reference or use the numeric keypad to enter a new reference value and confirm your choice with the ENTER key or a unit key.

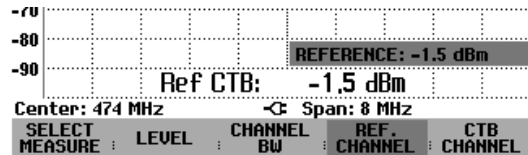

The R&S FSH3-TV interprets your input depending on the selected reference unit. It displays the reference in the bottom center of the screen. The measurement result is updated after each sweep.

## Selecting the Unit for the Reference

The R&S FSH3-TV can display the reference in the measurement screen either in dBm, dB $\mu$ V or dBmV.

- Press the MEASURE softkey until the measurement menu for the CATV analyzer appears.
- Press the LEVEL softkey.
- Using the rotary knob or the cursor keys, select the unit you want and confirm your choice with the ENTER key or the LEVEL softkey.

The result of the reference measurement is displayed in the selected unit.

## Blanking Out the Reference

The R&S FSH3-TV displays the reference at the bottom of the measurement screen. Usually this does not obscure the trace. However, if the trace is in this area of the screen, the display window can be removed from the screen.

Switch off the reference display.

- Press the MEASURE softkey until the measurement menu for the CATV analyzer appears.
- Press the REF MEASURE softkey.
- Using the rotary knob or the cursor keys, select WINDOW OFF and confirm your choice with the ENTER key or the REF MEASURE softkey.

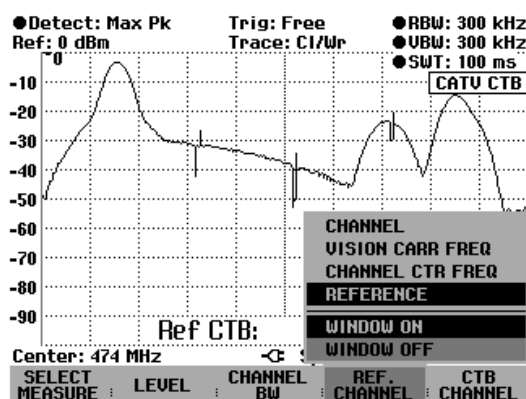

Switch on the reference display.

- Press the MEASURE softkey until the measurement menu for the CATV analyzer appears.
- Press the REF MEASURE softkey.
- Using the rotary knob or the cursor keys, select WINDOW ON and confirm your choice with the ENTER key or the REF MEASURE softkey.

*Note:* Switching the measured value window on and off will also affect the CTB measurement.

## Measuring the Composite Triple Beat Interference

Composite triple beat (CTB) interference represents undesired intermodulation products between the vision carriers. This is due to nonlinearities in the transmission system. CTB interference involves third-order intermodulation products which occur with vision carrier frequencies at the channel spacings. In cable TV systems, the individual intermodulation products tend to "pile up".

The CTB measurement result represents the ratio of the CTB interference power to the reference. The R&S FSH3-TV performs the measurement in two steps. In the first step, the reference is measured or determined so it can be used to compute the CTB ratio. In the second step, the R&S FSH3-TV measures the power of the CTB interference in compliance with EN 50083 standard in an unoccupied transmission channel and calculates its ratio to the reference power.

In order to increase the measurement dynamic range, the R&S FSH3-TV measures the noise power at a spacing of 100 kHz from the vision carrier and takes this into account in computing the CTB measured value.

### Screen Layout for the CTB Measurement

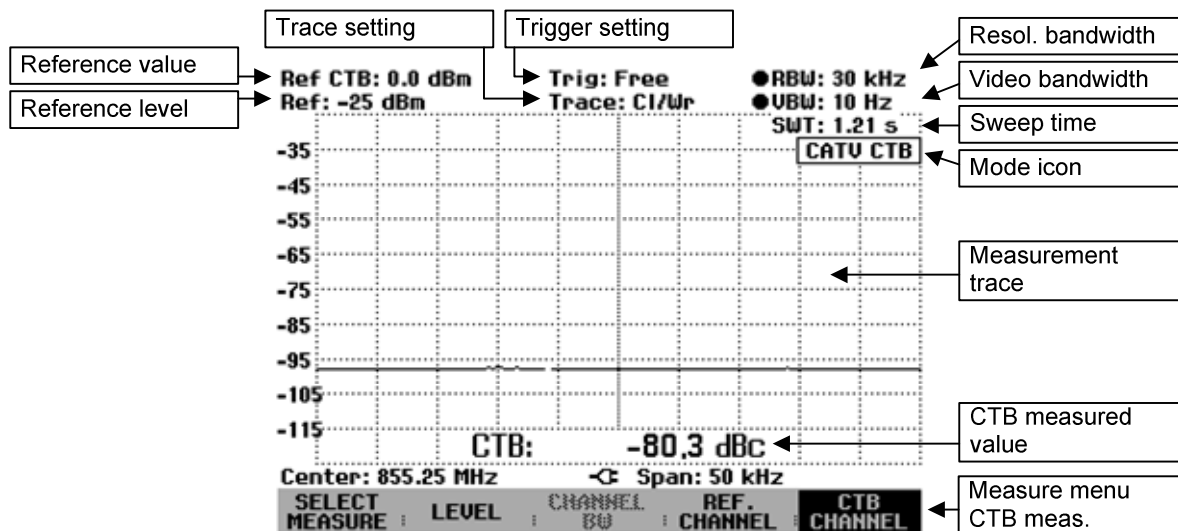

### Activating the CTB Measurement

After the CTB reference has been determined, it is necessary to activate the CTB measurement.

- Press the MEASURE softkey until the measurement menu for the CATV analyzer appears.
- Press the CTB MEASURE softkey.

The R&S FSH3-TV opens the menu for selection of the unoccupied channel in which the CTB interference is to be measured.

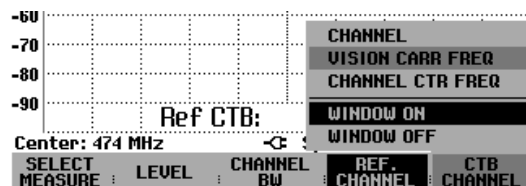

## Setting the CTB Receive Channel

You can set the frequency by entering the channel number for a loaded channel table, the vision carrier frequency or the channel center frequency.

When entering the channel center frequency, the R&S FSH3-TV computes the vision carrier frequency as a function of the channel bandwidth which was set in the reference measurement and the sideband setting.

Upper sideband: Vision carrier frequency = channel center frequency – channel bandwidth / 2 + 1.25 MHz

Lower sideband: Vision carrier frequency = channel center frequency + channel bandwidth / 2 - 1.25 MHz

*Note: The sideband is set in the BW menu. In the default setting, the R&S FSH3-TV automatically sets the proper sideband depending on the analog TV standard which is selected.*

When you enter the channel number, the R&S FSH3-TV computes the vision carrier frequency. It assumes in the computation that the channel center frequency is entered in the channel table. This is true for the supplied TV channel tables with the R&S FSH VIEW software and must be taken into account when creating channel tables.

➤ Using the cursor keys or the rotary knob, select CHANNEL, VISION CARR FREQ or CHANNEL CTR FREQ from the menu and confirm your choice with the ENTER key or the CTB MEASURE softkey.

The appropriate input box should open. There are the following possibilities:

- Use the rotary knob or the cursor keys to change the frequency or the channel.
- Use the numerical keypad to enter a new frequency or channel and confirm your input with the ENTER key or the CTB MEASURE softkey.
- Confirm the displayed frequency or channel with the ENTER key or the CTB MEASURE softkey.

The R&S FSH3-TV first measures the noise power in the CTB measurement channel at the vision carrier frequency +100 kHz. Then, it performs the CTB measurement in the selected receive channel. The following settings are made in compliance with the EN 50083 standard.

- The display range (span) is set to 50 kHz.
- The resolution bandwidth (RBW) is set to 30 kHz. A change in the resolution bandwidth changes the measurement result. Then, the measurement is no longer compliance with the EN 50083 standard.
- The MAX PEAK detector is set. The MAX PEAK detector is required for the measurement to be in compliance with the EN 50083 standard.
- The video bandwidth (VBW) is set to 10 Hz. A change in the video bandwidth changes the measurement result. Then, the measurement is no longer compliance with the EN 50083 standard.
- The sweep time is coupled to the span, resolution bandwidth and video bandwidth. In this setting, it is set to 1.21 seconds.

The R&S FSH3-TV measures the CTB interference, computes the ratio to the reference and displays the measurement result at the bottom center of the screen. The measurement result is updated after each sweep.

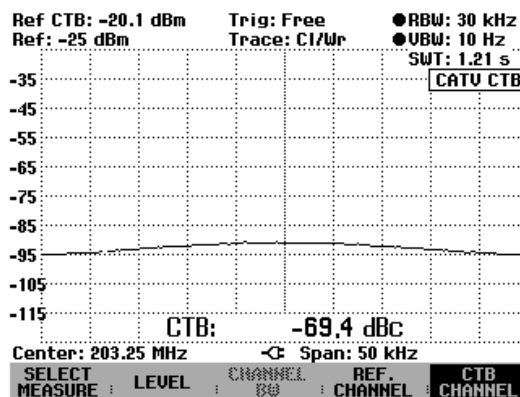

### Changing the CTB Measurement Channel

As described above, the CTB measurement channel can be selected when starting the CTB measurement in the CTB MEASURE menu or the FREQ menu. The setting is made by entering the vision carrier frequency, the channel number or the channel center frequency. The FREQ menu also allows you to select a frequency stepsize. When changing the frequency with the rotary knob or the cursor keys, the frequency change is based on this stepsize. When entering the channel with the rotary knob, the channel changes by one channel. With the cursor keys, it changes by ten channels. The channel table is also selected in the FREQ menu.

### Setting the Reference Level

The reference level influences the response of the receiver. Settings are made in the AMPT menu.

To simplify operation and to prevent incorrect measurements, the R&S FSH3-TV has an automatic routine for setting the reference level. During the CTB measurement, the LEVEL ADJUST function measures the power of the CTB noise "pile" depending on the reference level and then sets the reference level where the CTB noise power is lowest. This ensures that the R&S FSH3-TV is optimally set, irrespective of the channels and levels of the input signal.

- Press the MEASURE softkey until the measurement menu for the CATV analyzer appears.
- Press the LEVEL softkey.
- Confirm the LEVEL ADJUST preselection with the ENTER key or the LEVEL softkey.

## Trace Functions

The R&S FSH3-TV offers trace functions for use in determining the CTB measured value. The following settings are available:

- CLEAR/WRITE                      The R&S FSH3-TV clears the old trace during a new sweep. At the end of the sweep, the maximum value is used to compute the CTB. This is the default setting.
- AVERAGE                          The R&S FSH3-TV computes the average value based on consecutive measured traces and their associated CTB measured values. In the default setting, averaging is sliding over the ten previous measurement traces. Alternatively, you can set the number for the averaging from 2 to 999.
- MAX HOLD                          The trace indicates the maximum value that has been measured up to that point in time. The minimum CTB measured value which occurs is displayed. The R&S FSH3-TV interrupts the Max Hold mode only if another setting is selected and the trace and the CTB measured value no longer match one another.
- MIN HOLD                          The trace indicates the minimum value that has been measured up to that point in time. The maximum CTB measured value which occurs is displayed. The R&S FSH3-TV interrupts the Min Hold mode only if another setting is selected and the trace pixels from the new setting cannot be compared with the trace pixels from the previous setting.
- VIEW                                  The R&S FSH3-TV freezes the currently displayed trace and the associated CTB measured value. The measurement is aborted. This, for instance, allows subsequent evaluation of spectra with the aid of the marker.

### Operating sequence:

- Press the TRACE key.
- Press the TRACE MODE softkey.
- Using the rotary knob or the cursor keys, select the function you want and confirm your choice with the ENTER key or the TRACE MODE softkey.

If AVERAGE is selected, the AVG COUNT entry field opens and displays the set number of averagings.

The following actions can be performed:

- Confirm the displayed number of averagings with the TRACE softkey or the ENTER key.
- Using the numeric keypad, enter a new number between 2 and 999 for the number of averagings and confirm your entry with the TRACE softkey or the ENTER key.
- Change the number of averagings with the rotary knob or the cursor keys.

The R&S FSH3-TV averages the measured values over the set number of averagings.

If the sweep is continuous, the instrument then performs a sliding averaging. In SINGLE SWEEP mode, it performs exactly those sweeps defined with AVG COUNT and averages the measured values. It then stops the sweep and displays the average measured value.



## Blanking Out the CTB Measured Value

The R&S FSH3-TV displays the CTB measured value at the bottom of the measurement screen. Usually this does not obscure the trace. However, if the trace is in this area of the screen, the display window can be removed from the screen.

Blanking out the CTB measurement result.

- Press the MEASURE softkey until the measurement menu for the CATV analyzer appears.
- Press the CTB MEASURE softkey.
- Using the rotary knob or the cursor keys, select WINDOW OFF and confirm your choice with the ENTER key or the CTB MEASURE softkey.

Displaying the CTB measurement result.

- Press the MEASURE softkey until the measurement menu for the CATV analyzer appears.
- Press the CTB MEASURE softkey.
- Using the rotary knob or the cursor keys, select WINDOW ON and confirm your choice with the ENTER key or the CTB MEASURE softkey.

*Note: Switching the measured value window on and off will also affect the reference measurement.*

## Measuring the Composite Second Order Interference

Composite second order (CSO) interference represents undesired intermodulation products between the analog TV carriers. This is due to second-order nonlinearities in the transmission system. The CSO interference occurs at a frequency offset with respect to the vision carrier frequency. In cable TV systems, the individual intermodulation products tend to "pile up".

The CSO measurement result represents the ratio of the CSO interference power to the reference. The R&S FSH3-TV performs the measurement in two steps. In the first step, the reference is measured or determined so it can be used to compute the CSO ratio. In the second step, the R&S FSH3-TV measures the power of the CSO interference in compliance with EN 50083 standard in an unoccupied transmission channel and calculates its ratio to the reference power.

### Screen Layout for the CSO Measurement

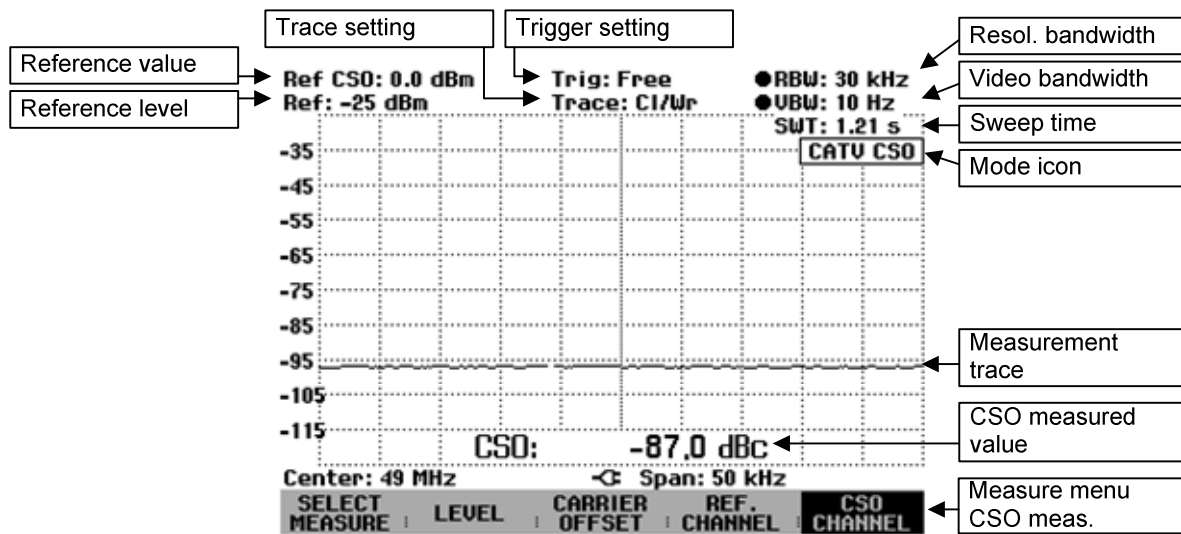

### Activating the CSO Measurement

After the CSO reference has been determined (see above), it is necessary to activate the CSO measurement.

- Press the MEASURE softkey until the measurement menu for the CATV analyzer appears.
- Press the CSO MEASURE softkey.

The R&S FSH3-TV opens the menu for selection of the unoccupied channel in which the CSO interference is to be measured.

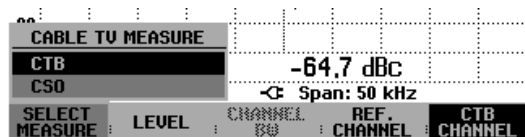

### Setting the CSO Receive Channel

You can set the frequency by entering the channel number for a loaded channel table, the vision carrier frequency or the channel center frequency.

When entering the channel center frequency, the R&S FSH3-TV computes the vision carrier frequency as a function of the channel bandwidth which was set in the reference measurement and the sideband setting.

Upper sideband:

$$\text{Vision carrier frequency} = \text{channel center frequency} - \text{channel bandwidth} / 2 + 1.25 \text{ MHz}$$

Lower sideband:

$$\text{Vision carrier frequency} = \text{channel center frequency} + \text{channel bandwidth} / 2 - 1.25 \text{ MHz}$$

*Note: The sideband is set in the BW menu. In the default setting, the R&S FSH3-TV automatically sets the proper sideband depending on the analog TV standard which is selected.*

When you enter the channel number, the R&S FSH3-TV computes the vision carrier frequency. It assumes in the computation that the channel center frequency is entered in the channel table. This is true for the supplied TV channel tables with the R&S FSH VIEW software and must be taken into account when creating channel tables.

- Using the cursor keys or the rotary knob, select CHANNEL, VISION CARR FREQ or CHANNEL CTR FREQ from the menu and confirm your choice with the ENTER key or the CSO MEASURE softkey.

The appropriate input box should open. There are the following possibilities:

- Use the rotary knob or the cursor keys to change the frequency or the channel.
- Use the numerical keypad to enter a new frequency or channel and confirm your input with the ENTER key or the CSO MEASURE softkey.
- Confirm the displayed frequency or channel with the ENTER key or the CSO MEASURE softkey.

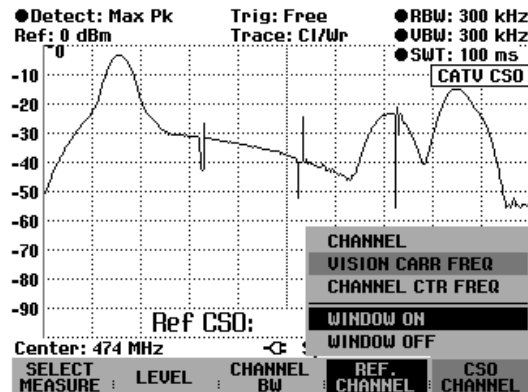

The R&S FSH3-TV first measures the noise power in the CSO measurement channel at the vision carrier frequency +100 kHz. Then, it performs the CSO measurement. Depending on the CATV system, the CSO interference occurs at a frequency spacing of ±250 kHz and ±750 kHz with respect to the vision carrier. The CSO interference with the greatest power determines the CSO measured value.

The R&S FSH3-TV measures all of the CSO interference in a sweep, compares the CSO power levels at the different offset frequencies and sets the receive frequency at which the maximum CSO interference was measured. The following settings are made in compliance with the EN 50083 standard.

- The display range (span) is set to 50 kHz.
- The resolution bandwidth (RBW) is set to 30 kHz. A change in the resolution bandwidth changes the measurement result. Then, the measurement is no longer compliance with the EN 50083 standard.
- The MAX PEAK detector is set. The MAX PEAK detector is required for the measurement to be in compliance with the EN 50083 standard.
- The video bandwidth (VBW) is set to 10 Hz. A change in the video bandwidth changes the measurement result. Then, the measurement is no longer compliance with the EN 50083 standard.
- The sweep time is coupled to the span, resolution bandwidth and video bandwidth. In this setting, it is set to 1.21 seconds.

The R&S FSH3-TV measures the CSO interference, computes the ratio to the reference and displays the measurement result at the bottom center of the screen. The measurement result is updated after each sweep.

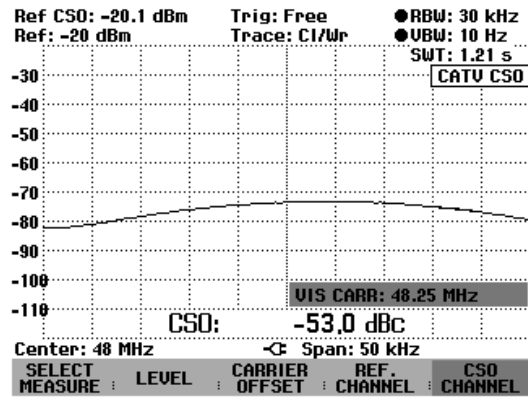

### Changing the Carrier Offset

Depending on the CATV system, the CSO interference occurs at a frequency spacing of  $\pm 250$  kHz and  $\pm 750$  kHz with respect to the vision carrier. You can choose the offset frequency at which the CSO ratio is measured.

- Press the MEASURE softkey until the measurement menu for the CATV analyzer appears.
- Press the CARRIER OFFSET softkey.
- Using the cursor keys or the rotary knob, select the offset frequency with respect to the vision carrier and confirm your choice with the ENTER key or the CARRIER OFFSET softkey.

The R&S FSH3-TV performs the CSO interference measurement at the selected frequency spacing with respect to the vision carrier frequency of the CSO measurement channel.

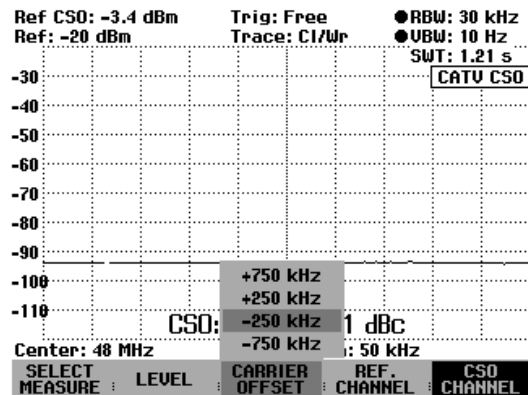

### Changing the CSO Measurement Channel

As described above, the CSO measurement channel can be selected when starting the CSO measurement in the CSO MEASURE menu or the FREQ menu. The setting is made by entering the vision carrier frequency, the channel number or the channel center frequency. The FREQ menu also allows you to select several frequency stepsizes. When changing the frequency with the rotary knob or the cursor keys, the frequency change is based on this stepsize. When entering the channel with the rotary knob, the channel changes by one channel. With the cursor keys, it changes by ten channels. The channel table is also selected in the FREQ menu.

## Setting the Reference Level

The reference level influences the response of the receiver. Settings are made in the AMPT menu.

To simplify operation and to prevent incorrect measurements, the R&S FSH3-TV has an automatic routine for setting the reference level. During the CSO measurement, the LEVEL ADJUST function measures the power of the CSO noise "pile" depending on the reference level and then sets the reference level where the CSO noise power is lowest. This ensures that the R&S FSH3-TV is optimally set, irrespective of the channels and levels of the input signal.

- Press the MEASURE softkey until the measurement menu for the CATV analyzer appears.
- Press the LEVEL softkey.
- Confirm the LEVEL ADJUST preselection with the ENTER key or the LEVEL softkey.

## Trace Functions

The R&S FSH3-TV offers trace functions for use in determining the CSO measured value. The following settings are available:

- CLEAR/WRITE                      The R&S FSH3-TV clears the old trace during a new sweep. At the end of the sweep, the maximum value is used to compute the CSO. This is the default setting.
- AVERAGE                         The R&S FSH3-TV computes the average value based on consecutive measured traces and their associated CSO measured values. In the default setting, averaging is sliding over the ten previous measurement traces. Alternatively, you can set the number for the averaging from 2 to 999.
- MAX HOLD                         The trace indicates the maximum value that has been measured up to that point in time. The minimum CSO measured value which occurs is displayed. The R&S FSH3-TV interrupts the Max Hold mode only if another setting is selected and the trace and the CSO measured value no longer match one another.
- MIN HOLD                         The trace indicates the minimum value that has been measured up to that point in time. The maximum CSO measured value which occurs is displayed. The R&S FSH3-TV interrupts the Min Hold mode only if another setting is selected and the trace pixels from the new setting cannot be compared with the trace pixels from the previous setting.
- VIEW                                The R&S FSH3-TV freezes the currently displayed trace and the associated CSO measured value. The measurement is aborted. This, for instance, allows subsequent evaluation of spectra with the aid of the marker.

**Operating sequence:**

- Press the TRACE key.
- Press the TRACE MODE softkey.
- Using the rotary knob or the cursor keys, select the function you want and confirm your choice with the ENTER key or the TRACE MODE softkey.

If AVERAGE is selected, the AVG COUNT entry field opens and displays the set number of averagings.

The following actions can be performed:

- Confirm the displayed number of averagings with the TRACE softkey or the ENTER key.
- Using the numeric keypad, enter a new number between 2 and 999 for the number of averagings and confirm your entry with the TRACE softkey or the ENTER key.
- Change the number of averagings with the rotary knob or the cursor keys.

The R&S FSH3-TV averages the measured values over the set number of averagings.

If the sweep is continuous, the instrument then performs a sliding averaging. In SINGLE SWEEP mode, it performs exactly those sweeps defined with AVG COUNT and averages the measured values. It then stops the sweep and displays the average measured value.

**Blanking Out the CSO Measured Value**

The R&S FSH3-TV displays the CSO measured value at the bottom of the measurement screen. Usually this does not obscure the trace. However, if the trace is in this area of the screen, the display window can be removed from the screen.

Blanking out the CSO measurement result.

- Press the MEASURE softkey until the measurement menu for the CATV analyzer appears.
- Press the CSO MEASURE softkey.
- Using the rotary knob or the cursor keys, select WINDOW OFF and confirm your choice with the ENTER key or the CSO MEASURE softkey.

Displaying the CSO measurement result.

- Press the MEASURE softkey until the measurement menu for the CATV analyzer appears.
- Press the CSO MEASURE softkey.
- Using the rotary knob or the cursor keys, select WINDOW ON and confirm your choice with the ENTER key or the CSO MEASURE softkey.

*Note: Switching the measured value window on and off will also affect the reference measurement.*

## Measuring the Carrier-to-Noise Ratio

The R&S FSH3-TV offers a carrier/noise measurement for measuring the ratio of carrier power to noise power. The R&S FSH3-TV performs the measurement in two steps.

First, it measures the carrier power of a transmission channel, or you determine a reference power which is then used for C/N calculation. In the second step, the R&S FSH3-TV measures the noise power of an unoccupied transmission channel and calculates the ratio of carrier power to noise power.

### Determining the carrier power (reference power or reference level)

The R&S FSH3-TV offers the carrier power measurement for three different types of carrier signals.

- **Digital Tx**

In the Digital Tx operating mode, the channel power of a reference channel with a digitally modulated signal is measured. This is common with digitally modulated carriers where power is equally distributed across the channel, i.e. where the carrier power is independent of the modulation signal.

- **Analog TV**

In the Analog TV operating mode, the peak power of the vision carrier is measured. This measurement method is common with amplitude-modulated TV signals.

- **CW Tx**

In the CW Tx operating mode, the power of an unmodulated carrier is measured.

- **Manual entry of a reference power or reference level**

The R&S FSH3-TV also allows you to manually enter the reference power or the reference level which will then be used for the carrier/noise calculation.

### Noise power and carrier-to-noise power ratios C/N and C/N<sub>0</sub>

For noise power measurements, the R&S FSH3-TV is set to an unoccupied transmission channel where it measures the noise power in accordance with the selected noise channel bandwidth.

The R&S FSH3-TV defines the carrier-to-noise ratio by determining the ratio of the previously determined reference to the measured noise power of the unoccupied transmission channel (C/N). The R&S FSH3-TV displays the ratio logarithmically.

$$C/N = \text{reference level} - \text{noise level in the channel}$$

If required, the R&S FSH3-TV determines the ratio with reference to the noise power density of the unoccupied transmission channel (C/N<sub>0</sub>).

$$C/N_0 = C/N + 10 \lg (\text{noise channel bandwidth/Hz})$$

### Operating sequence:

- Press the MEAS key.
- Press the MEASURE softkey.

The menu for measurement functions opens.

- Using the cursor keys or the rotary knob, select CARRIER / NOISE from the menu and confirm your choice with the ENTER key or the MEASURE softkey.

The R&S FSH3-TV activates the carrier/noise mode and starts the reference measurement that was selected last.

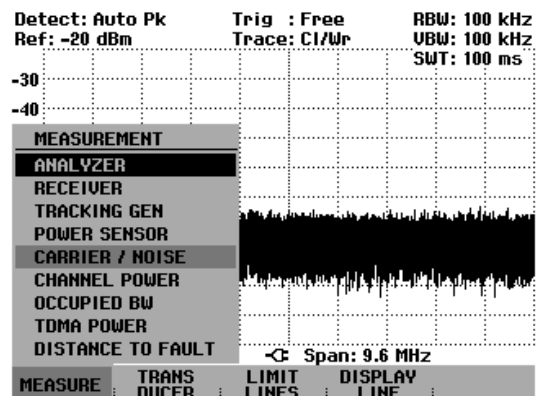

The major measurement parameter settings are available directly in the main menu of the carrier/noise measurement or can be entered using the corresponding function keys.

Center: 362 MHz		-G Ch BW: 8 MHz		
SELECT	LEVEL	CHANNEL	REF	NOISE
MEASURE	:	BW	MEASURE	MEASURE



## Determining the reference

Before the carrier-to-noise power ratio can be determined, the reference power or the reference level must be specified. To specify the reference, the R&S FSH3-TV offers four possibilities: the DIGITAL Tx, ANALOG TV, or CW Tx operating modes as well as manual reference. Enter the reference channel and the channel bandwidth of the reference channel to measure the reference. To indicate that the reference measurement has been activated, the REF MEASURE softkey is highlighted in green.

### DIGITAL Tx mode

In the Digital Tx operating mode, the channel power of a reference channel is selectively measured. It is then used as a carrier power (reference) for determining the carrier-to-noise ratio.

The settings for span, resolution bandwidth, video bandwidth and sweep time are coupled to the channel bandwidth and are optimally set by the R&S FSH3-TV.

If you want to change the settings, note the following:

- The span is preset to 1.2 times the reference channel bandwidth. The span is always coupled to the channel bandwidth. When changes are made, the R&S FSH3-TV automatically sets the appropriate span.
- The resolution bandwidth should be between 1% and 4% of the channel bandwidth. This ensures that the channel power is measured with good selectivity with respect to adjacent channels.
- The video bandwidth must be at least three times the resolution bandwidth. This prevents incorrect results due to the compression of signal peaks by the video filter.
- The RMS detector is recommended. It ensures that the power is always correctly measured irrespective of the waveform to be measured.
- Set the sweep time in such a way that the result is stable. If the sweep time is extended, the R&S FSH3-TV also increases the integration time for the RMS detector, thus yielding measured values that are more stable.

➤ Press the SELECT MEASURE softkey.

The menu for selecting the reference measurement opens.

➤ Using the rotary knob or the cursor keys, select DIGITAL Tx and confirm your choice with the ENTER key or the F1 softkey.

The R&S FSH3-TV starts the DIGITAL Tx reference measurement. C/N-DTx is inserted in the top right-hand corner of the display. The reference channel and the channel bandwidth are set in accordance with the last DIGITAL Tx reference measurement.

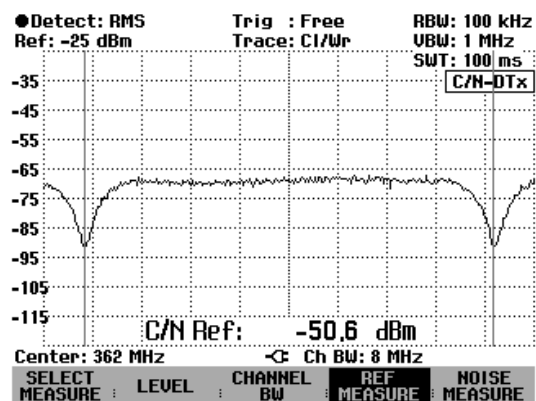

## ANALOG TV mode

In the ANALOG TV operating mode, the maximum power in the reference channel is measured. It is then used as the carrier power (reference) for determining the carrier-to-noise ratio.

To measure the peak power of the vision carrier, the settings for span, resolution bandwidth, video bandwidth and sweep time are optimally preset by the R&S FSH3-TV.

If you want to change the settings, note the following:

- The span is preset to the channel bandwidth of the reference channel. The span is coupled to the channel bandwidth. When changes are made, the R&S FSH3-TV automatically sets the appropriate span.
- The resolution bandwidth should be at least 300 kHz to ensure that the peak power of the vision carrier is sampled.
- The video bandwidth must be at least as wide as the resolution bandwidth. This prevents incorrect results due to the compression of signal peaks by the video filter.
- The peak detector is recommended. It ensures that the peak power of the vision carrier is correctly measured.
- The sweep time is coupled to span, resolution bandwidth and video bandwidth. Set the sweep time in such a way that the filters can settle. Too short a sweep time distorts the measurement result.

➤ Press the SELECT MEASURE softkey.

The menu for selecting the reference measurement opens.

➤ Using the rotary knob or the cursor keys, select ANALOG TV and confirm your choice with the ENTER key or the F1 softkey.

The R&S FSH3-TV starts the ANALOG TV reference measurement. C/N-ATV is inserted in the top right-hand corner of the display. Reference channel and channel bandwidth are set in accordance with the last ANALOG TV reference measurement.

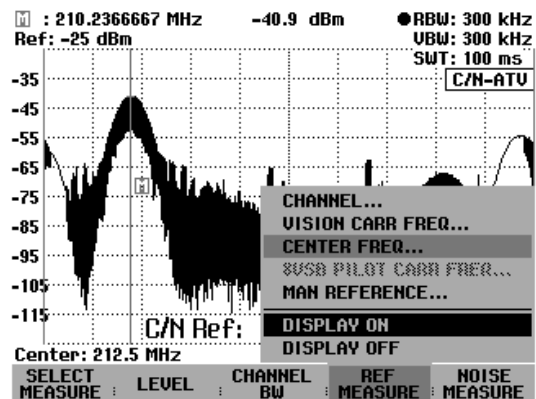

In the ANALOG TV operating mode, the count marker is automatically activated. After each sweep, the marker is set to the highest power in the reference channel. Marker power and marker frequency are indicated at the top edge of the display. The marker power corresponds to the reference.

**CW Tx mode**

In the CW Tx operating mode, the maximum power in the reference channel is measured, which is then used as a reference for determining the carrier-to-noise ratio.

The settings for span, resolution bandwidth, video bandwidth and sweep time are optimally set by the R&S FSH3-TV.

If you want to change the settings, note the following:

- The span is set and coupled to the channel bandwidth. When changes are made, the R&S FSH3-TV automatically sets the appropriate span.
- The resolution bandwidth is coupled to the channel bandwidth. When changes are made, the R&S FSH3-TV automatically sets the appropriate resolution bandwidth.
- The video bandwidth of the recommended peak detector must be at least as wide as the resolution bandwidth. If the RMS detector is used, the video bandwidth must be at least three times the resolution bandwidth. This prevents incorrect results due to the compression of signal peaks by the video filter.
- The peak detector is recommended. It ensures that the peak power of the vision carrier is correctly measured.
- The sweep time is coupled to span, resolution bandwidth and video bandwidth. Set the sweep time in such a way that the filters can settle. Too short a sweep time distorts the measurement result.

➤ Press the SELECT MEASURE softkey.

The menu for selecting the reference measurement opens.

➤ Using the rotary knob or the cursor keys, select CW Tx and confirm your choice with the ENTER key or the F1 softkey.

The R&S FSH3-TV starts the CW Tx reference measurement. C/N-CW Tx appears in the top right-hand corner of the display. Reference channel and channel bandwidth are set in accordance with the last CW Tx reference measurement.

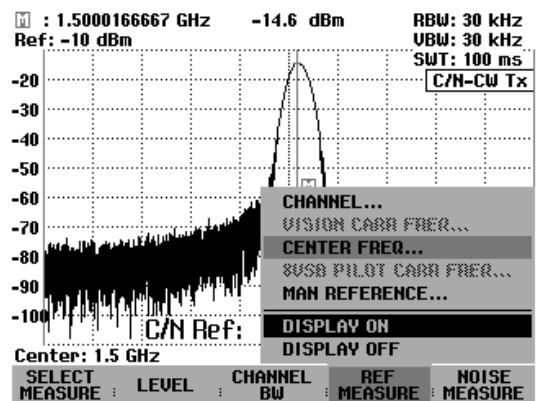

In the CW Tx operating mode, the count marker is automatically activated. After each sweep, the marker is set to the highest power in the reference channel. Marker power and marker frequency are indicated at the top edge of the display. The marker power corresponds to the reference.

**Manual reference mode**

As an alternative to the C/N reference measurement, the R&S FSH3-TV allows you to manually determine the C/N reference.

- Press the REF MEASURE softkey.
- Using the rotary knob or the cursor keys, select MAN REFERENCE POWER / LEVEL and confirm your choice with the ENTER key or the F4 softkey.
- Using the numeric keypad, enter the desired reference and terminate your entry with the appropriate unit key or the ENTER key.

The R&S FSH3-TV indicates the selected reference at the bottom of the display.

## Setting the reference channel

The reference channel is set by entering the channel number in accordance with the selected channel/frequency table or by entering the channel center frequency. In the DIGITAL Tx operating mode, the 8VSB/ATSC pilot frequency can also be entered. In the ANALOG TV operating mode, you can additionally enter the vision carrier frequency.

- Press the REF MEASURE softkey.
- Using the rotary knob or the cursor keys, select the desired entry and confirm your choice with the ENTER key or the F4 softkey.
- Using the numeric keypad, enter the channel or frequency of the desired reference channel.
- Terminate your entry with the appropriate unit key or the ENTER key.

The R&S FSH3-TV displays the frequency spectrum of the reference channel as symmetrical to the channel center.

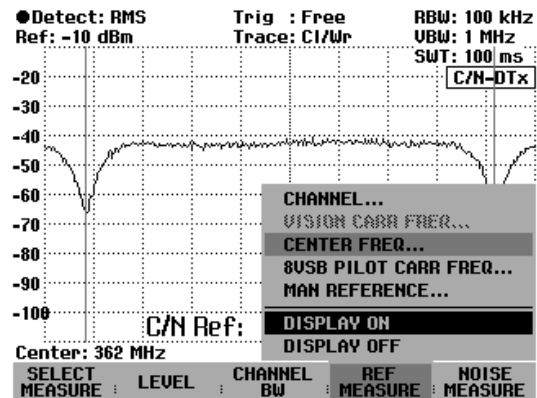

You can alternatively also enter the channel center frequency of the reference channel by pressing the FREQ function key.

## Setting the reference channel bandwidth

The reference channel bandwidth is entered with the CHANNEL BW softkey. Make the entry after the reference measurement has been activated. To indicate this, the REF MEASURE softkey is highlighted in green.

**Note:** *If the noise channel measurement has been activated, the NOISE MEASURE softkey is highlighted in green.*

- If DIGITAL Tx is set, the R&S FSH3-TV measures the power in accordance with the selected channel bandwidth. Measurement is performed selectively, i.e. any existing adjacent channels do not affect the measurement.
- If the 8VSB/ATSC pilot frequency is entered, the R&S FSH3-TV calculates the channel center frequency as a function of the 8VSB/ATSC symbol rate.  

$$\text{Channel center frequency} = \text{8VSB/ATSC pilot frequency} + \text{symbol rate} / 4,$$
 where the frequency of the 8VSB/ATSC symbol rate is 10.762238 MHz.
- If ANALOG TV is set, the R&S FSH3-TV measures the peak power of the vision power in the reference channel.
- If the vision carrier frequency is entered, the R&S FSH3-TV calculates the channel center frequency as a function of the channel bandwidth.  

$$\text{Channel center frequency} = \text{vision carrier frequency} - 1.25 \text{ MHz} + \text{reference channel bandwidth} / 2$$
- If CW Tx is set, the R&S FSH3-TV measures the peak power within the channel bandwidth.
- The R&S FSH3-TV indicates the channel limits by means of two blue vertical display lines.

**Operating sequence:**

- If the reference measurement is active, press the CHANNEL BW softkey.

An entry box showing the current channel bandwidth setting opens.

- Enter the reference channel bandwidth using the numeric keys and terminate your entry with the appropriate unit key, or
- Set the channel bandwidth with the rotary knob or the cursor keys.

The R&S FSH3-TV automatically adapts the span to the set channel bandwidth.

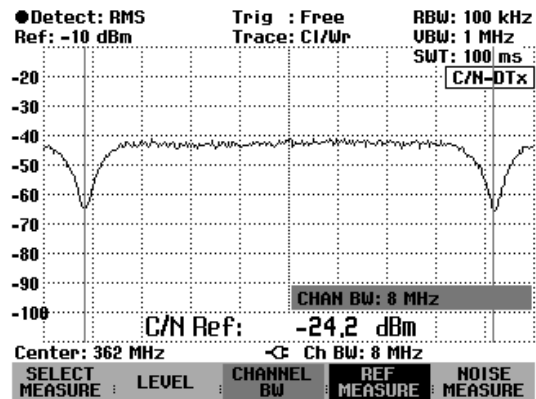

The minimum settable channel bandwidth is 834 Hz. If you attempt to enter a smaller channel bandwidth, the R&S FSH3-TV will automatically set 834 Hz and outputs the message "Limit exceeded".

**Setting the analyzer reference level for the reference channel measurement**

When selecting the reference level, make sure that the R&S FSH3-TV is not overdriven. Since the power is measured with a resolution bandwidth that is small in comparison with the signal bandwidth, the R&S FSH3-TV may be overdriven although the trace is within the measurement diagram. To prevent the R&S FSH3-TV from being overdriven, the signal can be measured at the largest possible resolution bandwidth using the peak detector. If this setting is selected, the trace must not exceed the reference level.

To simplify operation and to prevent incorrect measurements, the R&S FSH3-TV offers an automatic routine for setting the analyzer reference level.

- If the reference channel measurement is active (the REF MEASURE softkey is highlighted in green), press the LEVEL softkey.
- Confirm the LEVEL ADJUST selection with the ENTER key.

The R&S FSH3-TV starts the routine for determining the optimum reference level using a resolution bandwidth of 1 MHz, a video bandwidth of 1 MHz and the peak detector. During the measurement routine, a corresponding message is displayed.

The optimum reference level is then set.

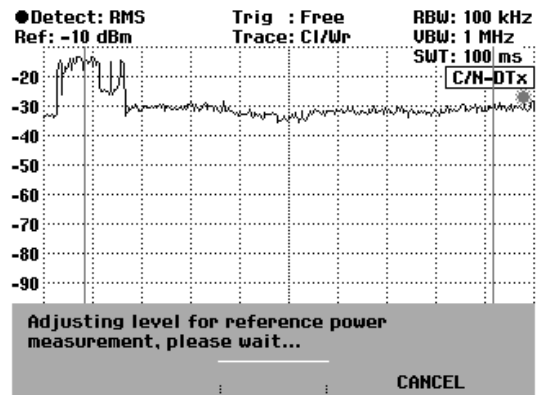

### Inserting the C/N reference

If the reference measurement has been activated, the R&S FSH3-TV inserts the reference power or the reference level at the bottom of the measurement diagram. Usually this does not obscure the trace. However, if the trace is in this area of the screen, the reference display can be blanked out.

Switch off the reference display.

- Press the REF MEASURE softkey.
- Using the rotary knob or the cursor keys, select DISPLAY OFF and confirm your choice with the ENTER key or the F4 softkey.

Switch the reference display on again.

- Press the REF MEASURE softkey.

Using the rotary knob or the cursor keys, select DISPLAY ON and confirm your choice with the ENTER key or the F4 softkey.

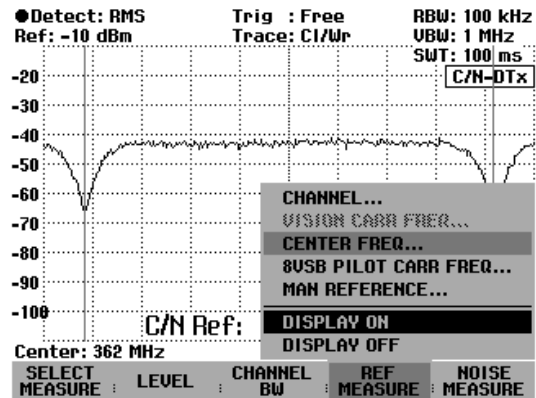

*Note: Switching the measurement result on or off also affects the insertion of the measured value of the noise measurement.*

### Units of the C/N reference

The R&S FSH3-TV displays the C/N reference as a level in dBm, dBμV or dBmV. The C/N reference is manually entered in accordance with the selected unit.

- Press the LEVEL softkey.
- Using the rotary knob or the cursor keys, select the desired unit and confirm your choice with the ENTER key or the F2 softkey.

The C/N reference is displayed in the selected unit.

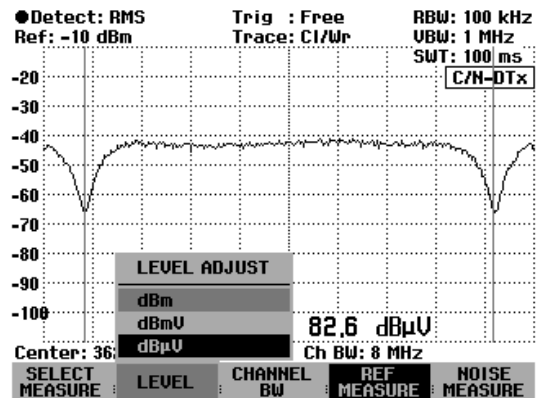

## Measuring the noise channel power and calculating the carrier power/noise power

The noise channel power is measured in an unoccupied transmission channel. The R&S FSH3-TV measures the spectrum within the channel using a resolution bandwidth that is small in comparison with the channel bandwidth. The measured values on the trace are then integrated to form the total power. The R&S FSH3-TV takes into account the behaviour of the selected display mode (linear or logarithmic) of the selected detector and the resolution bandwidth. The small resolution bandwidth acts like a steep channel filter, thus preventing out-of-channel emissions from affecting the result.

To determine the C/N power ratio, the measured noise channel power is set in relation to the reference.

$$\text{carrier/noise} = \text{reference/noise channel power}$$

The settings span, resolution bandwidth, video bandwidth and sweep time are coupled to the channel bandwidth and are optimally set by the R&S FSH3-TV.

If you want to change the settings, note the following:

- The span is coupled to the channel bandwidth. When changes are made, the R&S FSH3-TV automatically sets the appropriate span.
- The resolution bandwidth is coupled to the channel bandwidth. If it is set manually, it should be between 1% and 4% of the channel bandwidth. This ensures that the R&S FSH3-TV measures the channel power with good selectivity with respect to adjacent channels.
- The video bandwidth is coupled to the resolution bandwidth. If the RMS detector is used, the video bandwidth must be at least three times the resolution bandwidth. Thus, the video filter does not impair the power measurement by compressing signal peaks.
- The RMS detector is recommended. It ensures that the R&S FSH3-TV always measures the power correctly, irrespective of the measurement signal characteristics.
- Set the sweep time in such a way that the result is stable. If the sweep time is extended, the R&S FSH3-TV also increases the integration time for the RMS detector, thus yielding measured values that are more stable.

Press the NOISE MEASURE softkey to start the measurement. For calculation purposes, the R&S FSH3-TV uses the reference value that was last measured or manually set. During the noise channel measurement, it outputs the reference value at the top left edge of the display.

### Setting the noise channel

The noise channel is set by entering the channel number in accordance with the selected channel/frequency table, or by entering the channel center frequency, the vision carrier frequency or the 8VSB/ATSC pilot frequency.

- Press the NOISE MEASURE softkey.

The R&S FSH3-TV starts the noise channel measurement in the noise channel last set and opens the NOISE MEASURE menu for setting a new channel.

- Using the rotary knob or the cursor keys, select the desired noise channel entry and confirm your choice with the ENTER key or the NOISE MEASURE softkey.

The appropriate entry field opens.

- Using the numeric keys, enter the channel or the frequency of the desired transmission channel and terminate your entry with the appropriate unit key or the ENTER key.

The R&S FSH3-TV displays the frequency spectrum of the noise channel as symmetrical to the channel center.

You can alternatively enter the channel center frequency using the FREQ key.

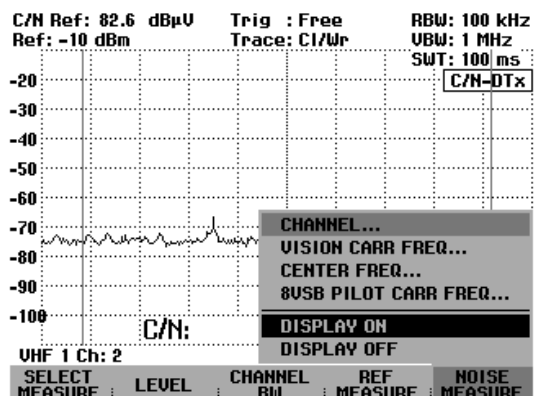

### Setting the noise channel bandwidth

Enter the noise channel bandwidth with the CHANNEL BW softkey. Make the entry after the noise channel measurement has been activated. This is the case when the NOISE MEASURE softkey is highlighted in green.

*Note: During the reference channel measurement, the REF MEASURE softkey is highlighted in green.*

The R&S FSH3-TV indicates the channel limits by means of two vertical display lines.

- If the noise channel measurement is active, press the CHANNEL BW softkey.

The R&S FSH3-TV opens the entry box for the channel bandwidth (CHAN BW) with the noise channel bandwidth just selected.

- Using the numeric keys, enter the noise channel bandwidth and terminate your entry with the appropriate unit key, or
- Set the noise channel bandwidth with the rotary knob or the cursor keys.

The R&S FSH3-TV automatically adapts the span to the set channel bandwidth.

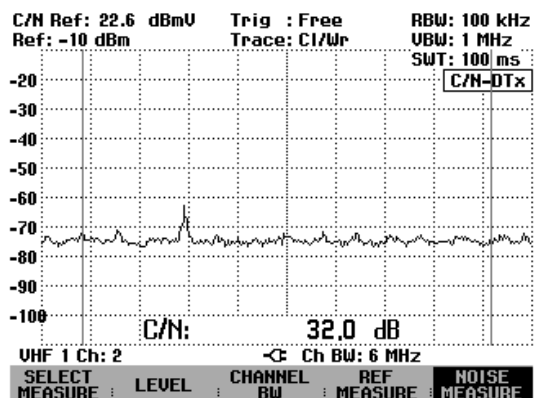

The minimum settable channel bandwidth is 834 Hz. If you attempt to enter a smaller channel bandwidth, the R&S FSH3-TV will automatically set 834 Hz and outputs the message "Limit exceeded".



### Setting the reference level during noise channel measurement

When selecting the reference level, make sure that the R&S FSH3-TV is optimally set with regard to the input signal. It must be set to be as sensitive as possible (corresponds to a low reference level) without being overdriven to ensure optimum C/N measurement results. This is the case when the measured noise power is at its lowest or the C/N ratio at its highest.

To simplify operation and to prevent incorrect measurements, the R&S FSH3-TV has an automatic routine for setting the reference level.

- If the noise channel measurement is active (the NOISE MEASURE softkey is highlighted in green), press the LEVEL softkey.
- Confirm the LEVEL ADJUST selection with the ENTER key.

The R&S FSH3-TV starts the routine for determining the optimum reference level. During the measurement routine, a corresponding message is displayed. The optimum reference level is then set.

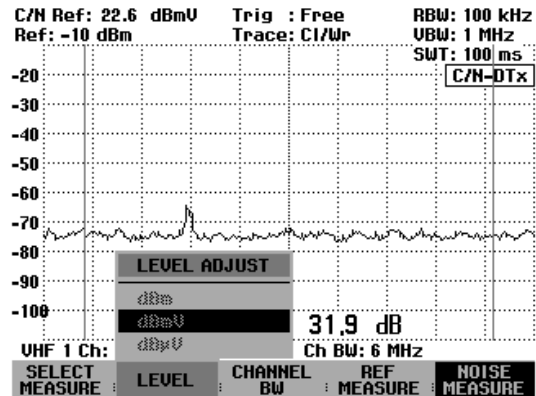

### Selecting the C/N result display

The R&S FSH3-TV either displays the carrier/noise power ratio referenced to the total noise channel power C/N or referenced to the noise power density C/No. It calculates the noise power density from the set noise channel bandwidth.

$$C/No = C/N + 10 \lg (\text{noise channel bandwidth})$$

- Press the SELECT MEASURE softkey.
- Using the rotary knob or the cursor keys, select the desired result display and confirm your choice with the ENTER key or the SELECT MEASURE softkey.

If the noise channel measurement is active, the R&S FSH3-TV displays the measured C/N or C/No value.

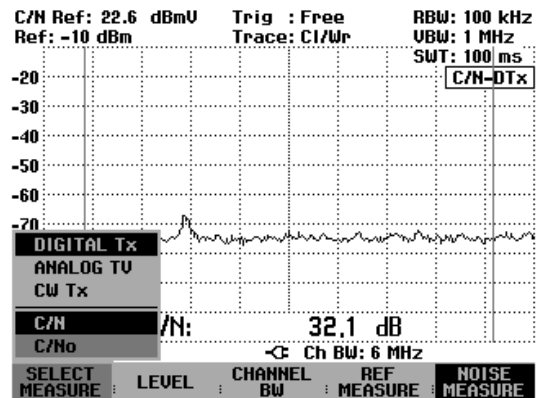

## C/N measurement result display

If the noise channel measurement is active, the R&S FSH3-TV inserts the C/N measurement result at the bottom of the measurement diagram. Usually this does not obscure the trace. However, if the trace is in this area of the screen, the display can be blanked out.

Switch off the C/N measurement result.

- Press the NOISE MEASURE softkey.
- Using the rotary knob or the cursor keys, select DISPLAY OFF and confirm your choice with the ENTER key or the F5 softkey.

Switch the C/N measurement result on again.

- Press the NOISE MEASURE softkey.

Using the rotary knob or the cursor keys, select DISPLAY ON and confirm your choice with the ENTER key or the F5 softkey.

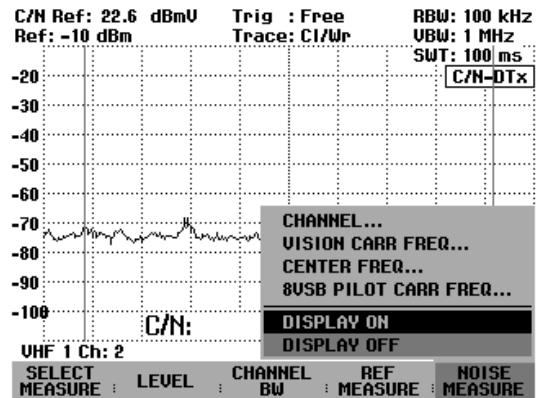

*Note:* Switching the C/N measurement result on or off also affects the insertion of the measured value of the reference measurement.

## Changing the span

The span set by the R&S FSH3-TV yields extremely precise measurement results. However, signals in the environment of the measurement channel can now no longer be detected. To give you an overview of the spectrum outside the measurement channel, the span can be changed up to a factor of ten times the channel bandwidth during the channel power measurement.

- Press the SPAN key.

The AUTO SPAN softkey is highlighted in green to indicate that the optimum span for the channel power measurement is set. MANUAL SPAN is activated to allow immediate entry of another span.

- Using the numeric keys, enter a new span and terminate the entry with the appropriate unit, or
- Change the span with the rotary knob or the cursor keys and terminate the entry with the ENTER key or the MANUAL SPAN softkey.

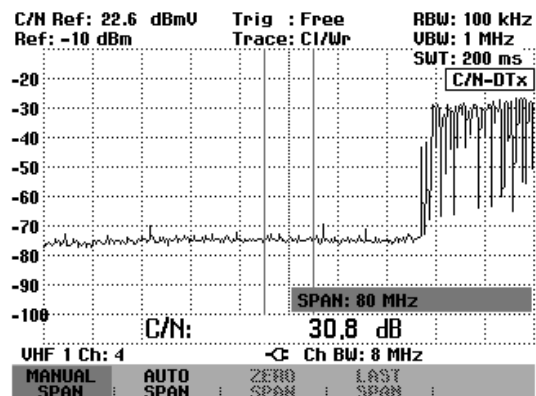

The largest permissible span for the channel power measurement is ten times the channel bandwidth. With larger spans, the result of the channel power measurement would be increasingly imprecise, because too few points of the trace occur in the channel to be measured.

- Press the AUTO SPAN softkey to reset the optimum span.
- To return to the menu for carrier/noise measurement, press the MEAS key.

# Measuring the channel power of continuously mod. signals

Thanks to the channel power measurement function, the power of modulated signals can be measured selectively. Unlike a power meter which measures power over its whole frequency range, the channel power mode allows the power in a specific transmission channel to be measured. Other signals in the frequency spectrum have no effect on the result.

When the channel power mode is selected, the R&S FSH3-TV determines the spectrum within the channel using a resolution bandwidth that is small in comparison with the channel bandwidth. The measured values on the trace are then integrated to give the total power. The R&S FSH3-TV takes into account the selected display mode (absolute or relative), the selected detector and the resolution bandwidth, which means that the result is comparable to the result that would have been obtained from a thermal power meter. The small resolution bandwidth acts like a narrow channel filter and so prevents out-of-channel emissions from affecting the result.

The R&S FSH3-TV has presets for the 3GPP WCDMA, cdmaOne and cdma2000 1x systems and so the user does not have to enter any settings himself. However, user-defined channel settings can also be entered to set up the R&S FSH3-TV for other communications systems.

### Operating sequence:

- Press the MEAS key.
- Press the MEASURE softkey.

The submenu for selecting the measurement functions opens.

- Using the rotary knob or the cursor keys, select the CHANNEL POWER menu item. (CHANNEL POWER highlighted in red)
- Confirm your selection with the ENTER key or the MEASURE softkey.

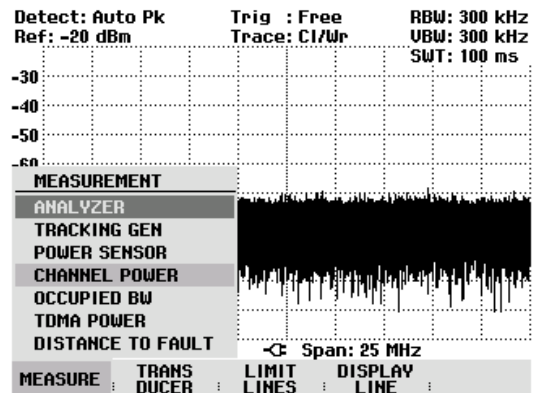

The R&S FSH3-TV displays the softkey menu for setting the channel power measurement. Two vertical lines in the measurement diagram indicate the channel bandwidth. The measured channel power is shown in large letters below the measurement diagram.

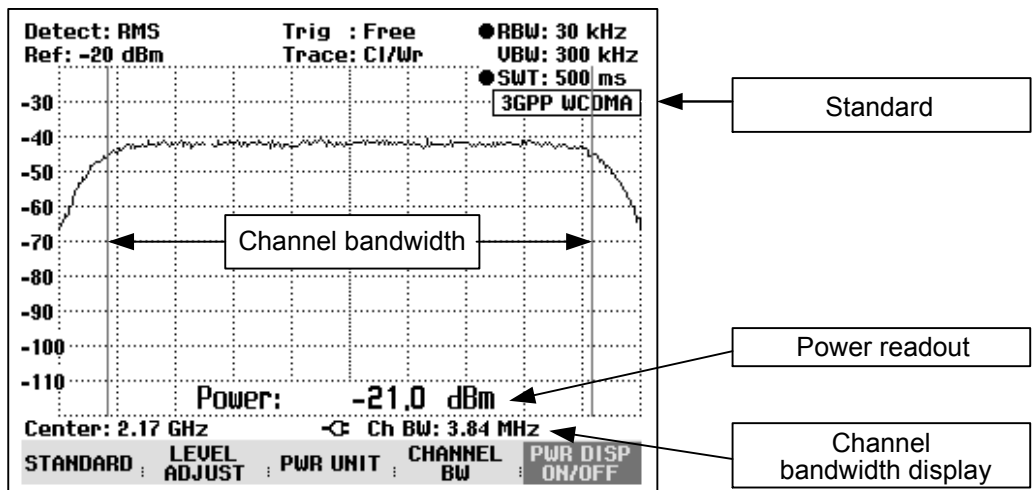

The default setting is power measurement for 3GPP WCDMA signals.

## Selecting the standard

The R&S FSH3-TV has a channel power measurement default setting for various standards. It is also possible to define and save user-specified configurations.

➤ Press the STANDARD softkey.

A submenu with the available standards opens.

➤ Select the standard you want using the rotary knob or the cursor keys.

➤ Confirm your selection with the ENTER key or the STANDARD softkey.

The R&S FSH3-TV sets the selected standard. The optimal span, resolution bandwidth, video bandwidth, sweep time and detector for the standard are selected automatically.

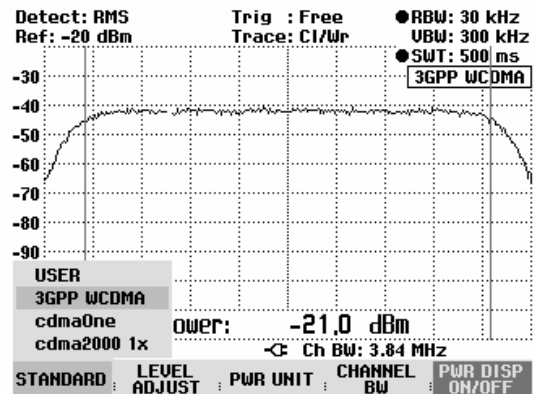

If USER is selected, the R&S FSH3-TV sets the last channel power measurement setting used in the USER mode. The R&S FSH3-TV automatically makes changes to the setting so that it is again available when the USER standard is called again.

The following should be noted when changes to the settings are made:

- The span is always coupled to the channel bandwidth. When changes are made, the R&S FSH3-TV automatically sets the appropriate span.
- The resolution bandwidth should be between 1 % and 4 % of the channel bandwidth. This means that the channel power measurement has good selectivity with respect to adjacent channels.
- The video bandwidth must be at least three times the resolution bandwidth. This prevents incorrect results due to the compression of signal peaks by the video filter.
- The RMS detector is recommended. This ensures that the true power is always obtained irrespective of the shape of the signal being investigated.
- The sweep time must be set so that the result is stable. If the sweep time is increased, the R&S FSH3-TV also increases the integration time for the RMS detector and so ensures more stable measured values.

**Renaming the USER standard:**

The setting for the USER standard can be assigned a user-defined name. Thus, the setting used by the R&S FSH3-TV in the USER setting is immediately clear. The name entered as the USER standard also appears on the screen, thus making it possible to document the setting along with the measurement.

- Press the STANDARD softkey.
- A table with the available standards opens.
- Select Rename USER with the rotary knob or the cursor keys.
- Confirm your selection with the ENTER key or the STANDARD softkey.

The R&S FSH3-TV will open the input window for the name of the USER standard.

- Using the numeric keys, enter a name.
- Press the ENTER key to complete the entry.

When the STANDARD menu is called, the entered name appears under USER (e.g. DAB (USER)). The name also appears at the top right-hand corner of the screen after the USER standard is selected.

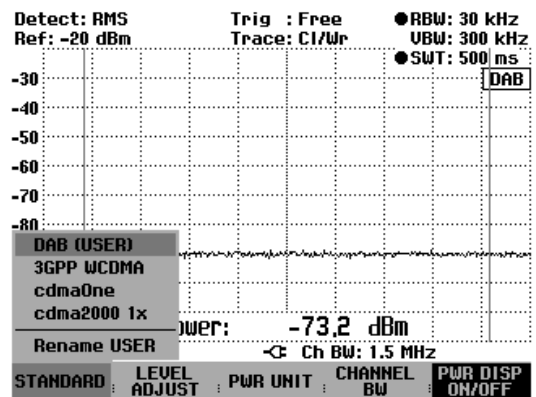
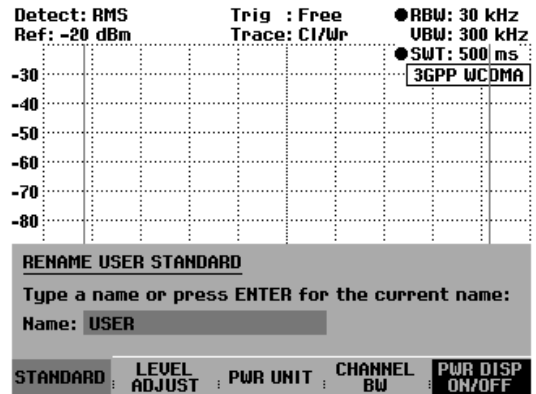

Using the R&S FSH View control software, additional standards can be generated and permanently loaded into the R&S FSH3-TV. You can also delete the factory-set standards provided in the instrument if you do not need them. The R&S FSH3-TV then offers only the standards you require, for example for measurements on TV signals.

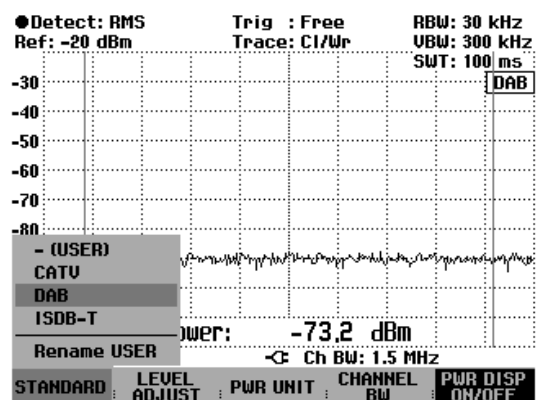

## Setting the reference level

When selecting the reference level, ensure that the R&S FSH3-TV is not overdriven. As the power is measured with a resolution bandwidth that is small in comparison with the signal bandwidth, the R&S FSH3-TV may still be overdriven even though the trace is still within the measurement diagram. To prevent the R&S FSH3-TV from being overdriven, the signal can be measured at the largest resolution bandwidth possible using the peak detector. If this setting is selected, it is not possible for the trace to exceed the reference level. To simplify operation and to prevent incorrect measurements, the R&S FSH3-TV has an automatic routine for setting the reference level.

- Press the LEVEL ADJUST softkey.

The R&S FSH3-TV starts the measurement of the optimal reference level using a resolution bandwidth of 1 MHz, a video bandwidth of 1 MHz and the peak detector. During the measurement, the message "Adjusting level for channel power measurement, please wait..." is output.

The optimal reference level is then set.

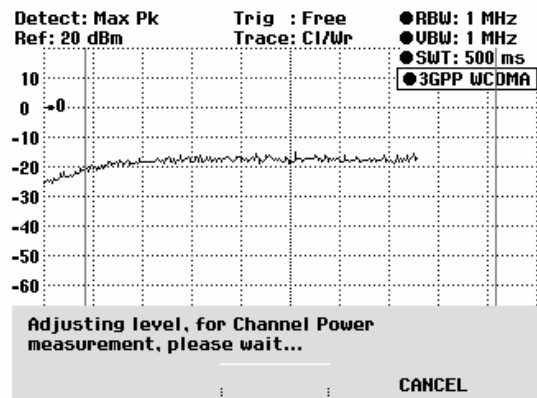

## Setting the channel bandwidth

The channel bandwidth specifies the frequency range about the center frequency, over which the R&S FSH3-TV performs the power measurement.

- Press the CHAN BW softkey.

The value entry box showing the current channel bandwidth setting opens.

- Using the number keys enter a new channel bandwidth and terminate the entry with the appropriate unit, or
- Using the rotary knob or the cursor keys, change the channel bandwidth and confirm with the ENTER key or the CHANNEL BW softkey.

The R&S FSH3-TV automatically sets the appropriate span for the channel bandwidth that has been entered (span = 1.2 x channel bandwidth) to ensure that no incorrect channel power measurements are made.

The minimum settable channel bandwidth is 834 Hz. If you attempt to enter a smaller channel bandwidth, the R&S FSH3-TV will automatically set 834 Hz and outputs the message "Limit exceeded".

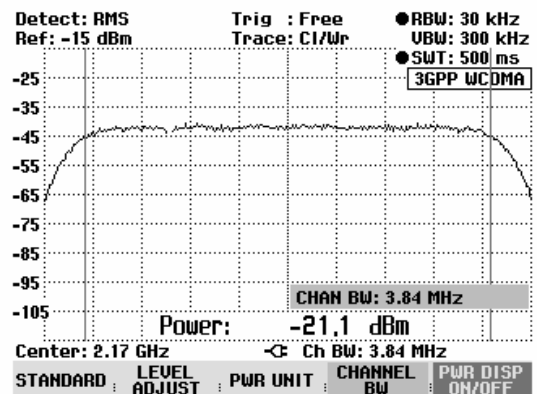

## Changing the span

The span set by the R&S FSH3-TV yields extremely precise measurement results. However, signals in the environment of the measurement channel are no longer detectable. To enable users to see the spectrum outside the measurement channel, the span can be changed up to a factor of ten times the channel bandwidth during the channel power measurement.

### Operation:

- Press the SPAN key.

The AUTO SPAN softkey label is highlighted in green to indicate that the optimum span for the channel power measurement is set. MANUAL SPAN is activated to allow immediate entry of another span.

- Using the numeric keys, enter a new span and terminate the entry with the appropriate unit, or
- Change the span with the rotary knob or the cursor keys and terminate the entry with the ENTER key or the MANUAL SPAN softkey.

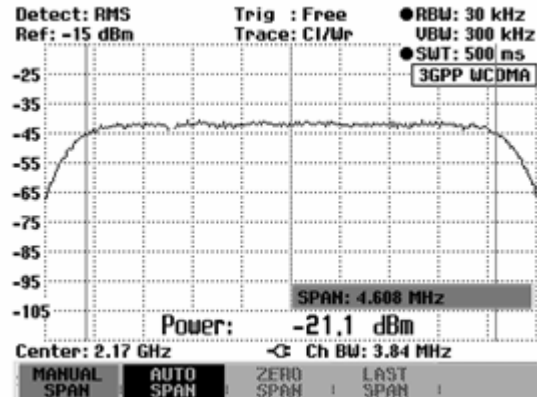

The largest permissible span for the channel power measurement is ten times the channel bandwidth. At larger spans, the result of the channel power measurement would be increasingly imprecise, because too few points of the trace occur in the channel to be measured.

- Press the AUTO SPAN softkey to again set the optimum span.
- To return to the menu for channel power measurement, press the MEAS key.

## Power display

The R&S FSH3-TV displays the power at the bottom of the measurement diagram (Power = nn.n dBm). Usually the trace is not obscured. However, if the trace is in this area of the screen, the power readout can be removed from the screen. Simply press the PWR DISP ON/OFF softkey. If the softkey label is highlighted in green, the power readout is on.

**Unit for power display:**

The R&S FSH3-TV can use different units for power output. The basic unit is dBm.

- Press the PWR UNIT softkey.

The R&S FSH3-TV opens the submenu with the units: dBm, dBmV and dBμV.

- Using the rotary knob or the cursor keys, select the required unit.
- Confirm your selection with the ENTER key or the PWR UNIT softkey.

The R&S FSH3-TV displays the power level in the selected unit.

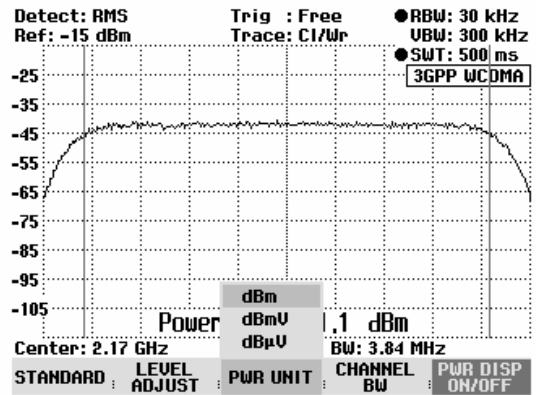



## Power measurements on TDMA signals

When TDMA (time division multiple access) methods are used, e.g. for GSM, several users share a channel. Each user is assigned a period of time or timeslot. The R&S FSH3-TV's TDMA POWER function measures the power over one of these timeslots. This is a time-domain measurement (span = 0 Hz). The power measurement is started on an external trigger or the video trigger. The power measurement time is selected with MEAS TIME.

To prevent incorrect power measurements in the time domain, ensure that the whole signal lies within the selected resolution bandwidth. If the resolution bandwidth is too narrow, the displayed power will be lower than the actual power.

- Press the MEAS key.
- Press the MEASURE softkey.

The submenu for selecting the measurement functions opens.

- Using the rotary knob or the cursor keys select the TDMA POWER menu item.
- Confirm your selection with the ENTER key or the MEAS softkey.

The R&S FSH3-TV displays the softkeys for configuring time-domain power measurements.

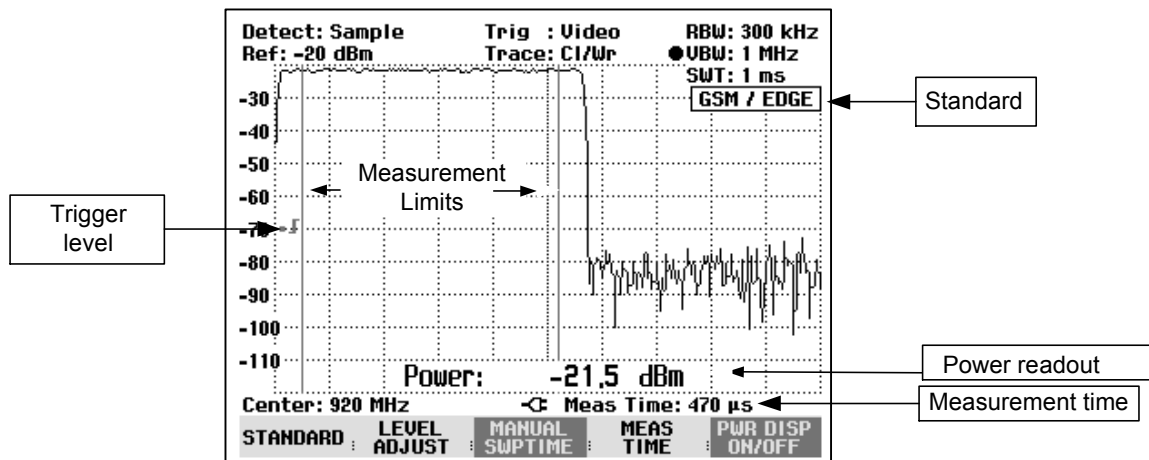
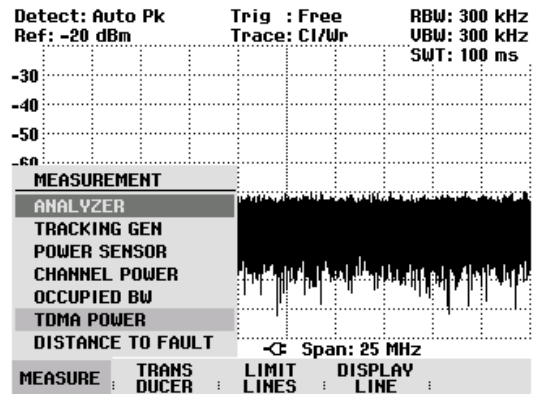

## Selecting a standard

When the function is switched on, the R&S FSH3-TV automatically selects the GSM/EDGE standard. All default settings are selected so that power measurements on GSM or EDGE bursts give true readings.

A different default setting can be configured with USER.

- Press the STANDARD softkey.
- Using the rotary knob or the cursor keys, select the USER menu item.
- Confirm your selection with the ENTER key or the STANDARD softkey.

The USER STANDARD settings that have already been stored are set on the R&S FSH3-TV. When the USER STANDARD is called for the first time, it sets the measurement parameters for the GSM/EDGE standard.

If the USER STANDARD is set, the R&S FSH3-TV automatically accepts all measurement parameter changes so that they are available next time USER STANDARD is selected.

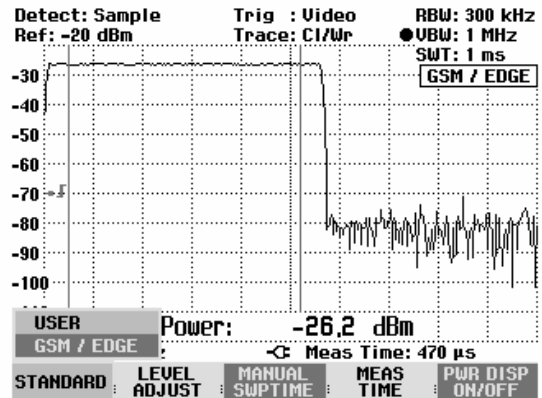

### Renaming the USER standard:

The setting for the USER standard can be assigned a user-defined name. The name entered as the USER standard also appears on the screen, thus making it possible to document the setting along with the measurement.

- Press the STANDARD softkey.

A table with the available standards opens.

- Select Rename USER with the rotary knob or the cursor keys.
- Confirm your selection with the ENTER key or the STANDARD softkey.

The R&S FSH3-TV will open the input window for the name of the USER standard.

- Using the numeric keys, enter a name.
- Press the ENTER key to complete the entry.

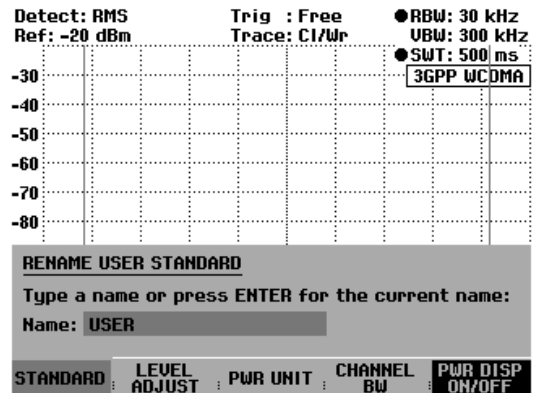

When the STANDARD menu is called, the entered name appears under USER (e.g. TETRA (USER)). The name also appears at the top right-hand corner of the screen after the USER standard is selected.

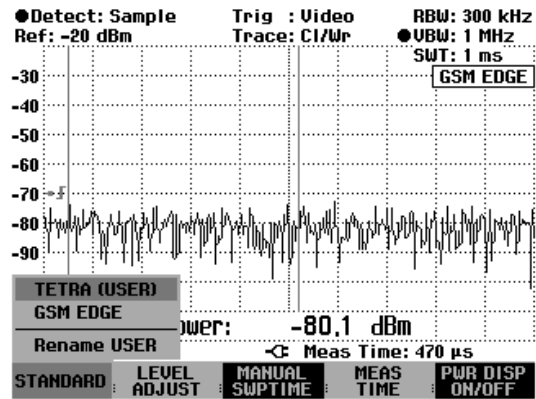

Using the R&S FSH View control software, additional standards can be generated and permanently loaded into the R&S FSH3-TV. You can also delete the factory-set standards provided in the instrument if you do not need them. The R&S FSH3-TV then offers only the standards you require.

## Setting the measurement time

The measurement time (MEAS TIME) is the time over which the R&S FSH3-TV performs a power measurement. A value less than or equal to the sweep time can be selected.

- Press the MEAS TIME softkey.

The value entry box displaying the current measurement time opens.

- Using the number keys, enter a new measurement time and terminate the entry with the appropriate unit, or
- Using the rotary knob or the cursor keys change the measurement time and confirm with the ENTER key or the MEAS TIME softkey.

If the measurement time you have entered is greater than the sweep time, the R&S FSH3-TV outputs the message "Maximum reached" and sets a measurement time equal to the sweep time. If you want to set a longer measurement time, you must increase the sweep time first.

The minimum measurement time is the time corresponding to one trace pixel (= sweep time /301).

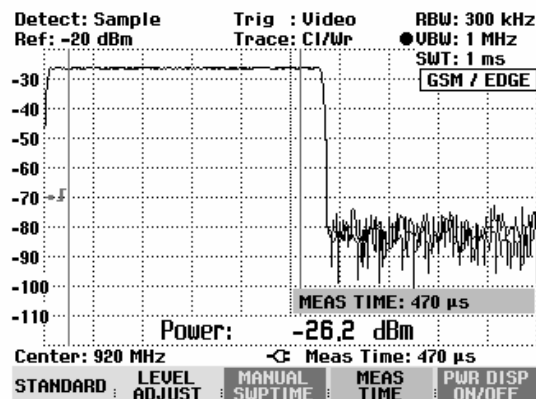

## Optimizing the reference level

To obtain the greatest possible dynamic range for burst signals, the lowest reference level possible must be set. If this is not done, the R&S FSH3-TV will be overdriven by the measurement signal, if its maximum level exceeds the maximum reference level. Because the R&S FSH3-TV's resolution bandwidths are implemented digitally after the A/D converter, depending on the resolution bandwidth selected, the signal level at the A/D converter can be higher than the level indicated by the trace. To prevent the A/D converter from being overdriven, the signal must be measured at the widest resolution bandwidth (1 MHz) and video bandwidth (1 MHz) with the peak detector. The trace maximum then determines the optimal reference level.

The R&S FSH3-TV's LEVEL ADJUST routine will automatically determine the optimal reference level for you.

➤ Press the LEVEL ADJUST softkey.

The R&S FSH3-TV starts the measurement to determine the optimal reference level, using a resolution bandwidth of 1 MHz, a video bandwidth of 1 MHz and the peak detector. While the measurement is in progress, the R&S FSH3-TV outputs the message "Adjusting level for TDMA power measurement, please wait...".

The optimal reference level is then set.

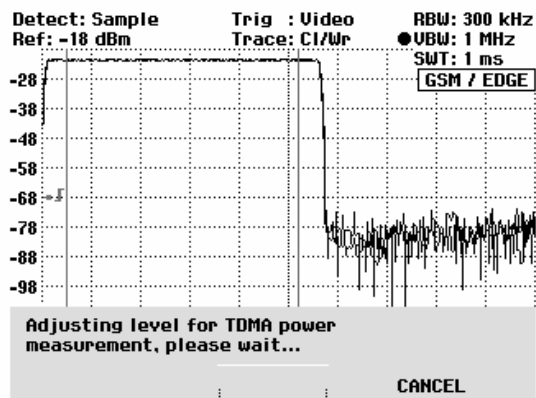

## Power readout

The R&S FSH3-TV displays the measured power at the bottom of the measurement diagram (Power = nn.n dBm). Usually the trace is not obscured. However, if the trace is in this area of the screen, the power readout can be removed from the screen. Simply press the PWR DISP ON/OFF softkey. If the softkey label is highlighted in green, the power readout is on.

## Setting the trigger

A trigger is usually required to perform power measurements on bursts. In the default setting, the R&S FSH3-TV is configured to use the video trigger at 50 % of the Y scale on the measurement diagram. Assuming that the burst on which the measurement is to be made crosses the 50 % point of the trigger, the R&S FSH3-TV will trigger on the rising edge of the burst.

Should this not be the case, the trigger level must be adjusted so that the R&S FSH3-TV is triggered by the burst edge. Otherwise no measurement will be performed.

If the DUT has a trigger facility, the external trigger can also be used for the measurement.

- Connect the DUT's trigger output to the R&S FSH3-TV's trigger input.
- Press the SWEEP key.
- Press the TRIGGER softkey.
- Select the EXTERN menu item (rising or falling edge).
- Confirm your selection with the ENTER key or the TRIGGER softkey.

Select the appropriate trigger delay to position the burst in the measurement window.

- Press the DELAY... softkey.
- Using the rotary knob or the cursor keys, adjust the trigger delay until the TDMA burst is inside the vertical lines indicating the measurement range, or
- Using the number keys, enter the appropriate trigger delay and terminate the entry with the appropriate unit key.

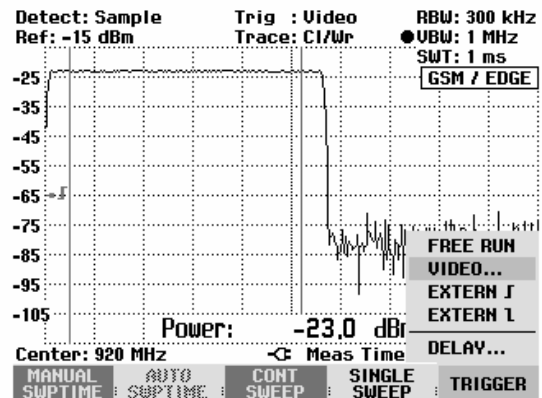

## Measuring the occupied bandwidth

Ensuring the proper operation of a transmission network requires that all transmitters adhere to the bandwidths assigned to them. This is checked by measuring the occupied bandwidth, which is defined as the bandwidth in which a specified percent (99 %) of power is transmitted.

One of the measurement functions of the R&S FSH3-TV is the measurement of occupied bandwidth. After the channel bandwidth has been entered, the R&S FSH3-TV automatically selects the measurement parameters so that an optimal result is attained.

### Operating sequence:

- Press the MEAS key.
- Press the MEASURE softkey.

The R&S FSH3-TV opens the menu containing the measurement functions.

- Using the rotary knob or the cursor, select OCCUPIED BW from the menu (highlighted in red).
- Confirm your selection with the ENTER key or the MEASURE softkey.

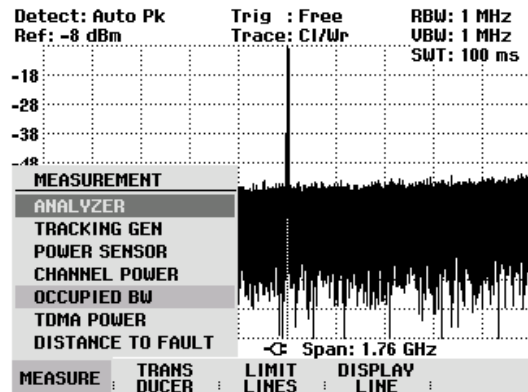

The R&S FSH3-TV displays the softkey menu for setting the measurement of occupied bandwidth. Two vertical lines in the measurement diagram indicate the occupied bandwidth. The measured numeric value (OBW) is shown in large characters below the measurement diagram.

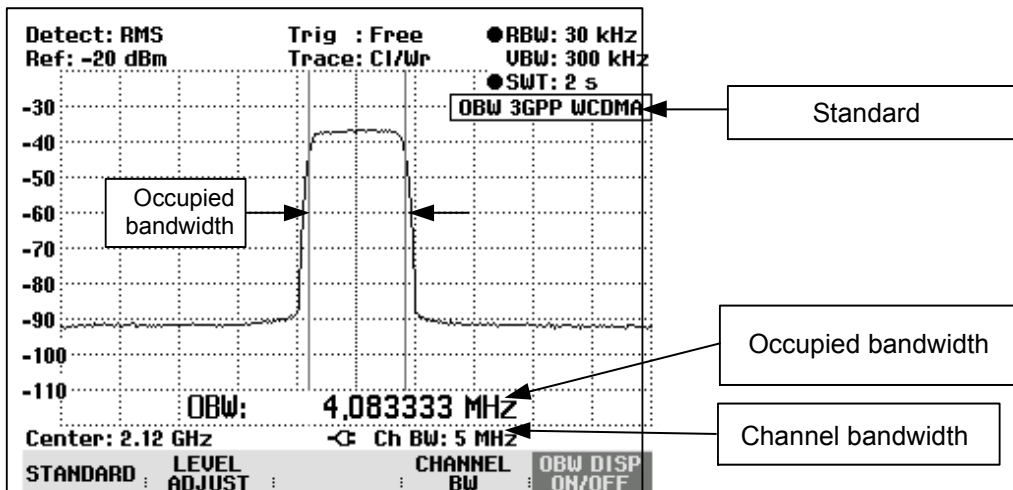

## Selecting a standard

The R&S FSH3-TV offers a default for measuring the occupied bandwidth for different standards. It is also possible to define and save user-specific configurations.

➤ Press the STANDARD softkey.

A table with the available standards opens.

➤ Using the rotary knob or the cursor keys, select the appropriate standard.

➤ Confirm your selection with the ENTER key or the STANDARD softkey.

The selected standard is set. The optimal span, resolution bandwidth, video bandwidth, sweep time and detector for the standard are selected automatically.

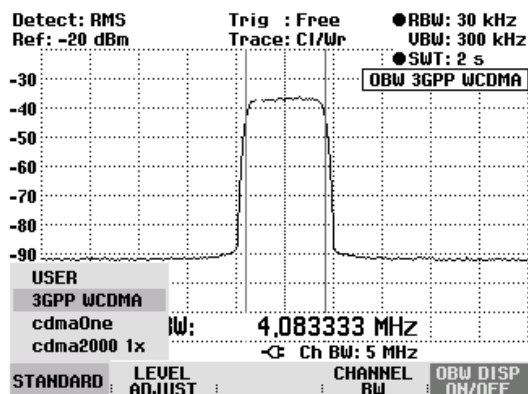

If USER is selected, the R&S FSH3-TV restores the last setting used in the USER mode for measuring the occupied bandwidth. The R&S FSH3-TV automatically makes changes to the setting so that it is again available when USER is called again.

The following should be noted when changes to the settings are made:

- The span is always coupled to the channel bandwidth (CHANNEL BW). When changes are made, the R&S FSH3-TV automatically sets the appropriate span (= 5 x channel bandwidth).
- The resolution bandwidth should be between 1% and 4% of the channel bandwidth. This ensures that the occupied bandwidth is measured with high accuracy.
- The video bandwidth must be at least three times the resolution bandwidth. This prevents incorrect results due to the compression of signal peaks by the video filter.
- The RMS detector is recommended. This ensures that the power measurement is always correct irrespective of the waveform being investigated.
- The sweep time must be set so that the result is stable. If the sweep time is increased, the R&S FSH3-TV also increases the integration time for the RMS detector and thus ensures more stable measured values.

**Renaming the USER standard:**

The setting for the USER standard can be assigned a user-defined name. The name entered as the USER standard also appears on the screen, thus making it possible to document the setting along with the measurement.

- Press the STANDARD softkey.

A table with the available standards opens.

- Select Rename USER with the rotary knob or the cursor keys.
- Confirm your selection with the ENTER key or the STANDARD softkey.

The R&S FSH3-TV will open the input window for the name of the USER standard.

- Using the numeric keys, enter a name.
- Press the ENTER key to complete the entry.

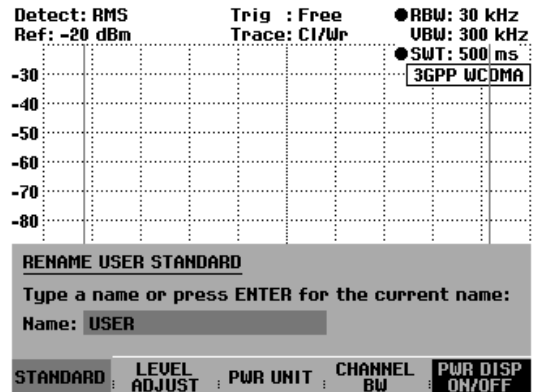

When the STANDARD menu is called, the entered name appears under USER (e.g. DAB (USER)). The name also appears at the top right-hand corner of the screen after the USER standard is selected.

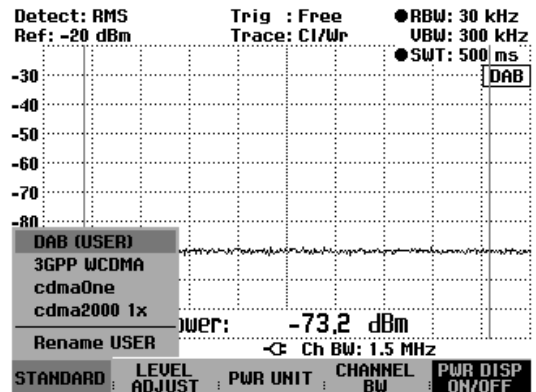

Using the R&S FSH View control software, additional standards can be generated and permanently loaded into the R&S FSH3-TV. You can also delete the factory-set standards provided in the instrument if you do not need them. The R&S FSH3-TV then offers only the standards you require.



## Setting the reference level

When selecting the reference level, ensure that the R&S FSH3-TV is not overdriven. As the power is measured with a resolution bandwidth that is small in comparison with the signal bandwidth, the R&S FSH3-TV may still be overdriven even though the trace is within the measurement diagram. To prevent the R&S FSH3-TV from being overdriven, the signal can be measured at the largest resolution bandwidth possible using the peak detector. If this setting is selected, the trace may not exceed the reference level.

To simplify operation and to prevent incorrect measurements, the R&S FSH3-TV has an automatic routine for setting the reference level.

- Press the LEVEL ADJUST softkey.

The R&S FSH3-TV starts the measurement of the optimal reference level using a resolution bandwidth of 1 MHz, a video bandwidth of 1 MHz and the peak detector. While the measurement is in progress, the R&S FSH3-TV outputs the message "Adjusting level for OBW measurement, please wait...".

The optimal reference level is then set.

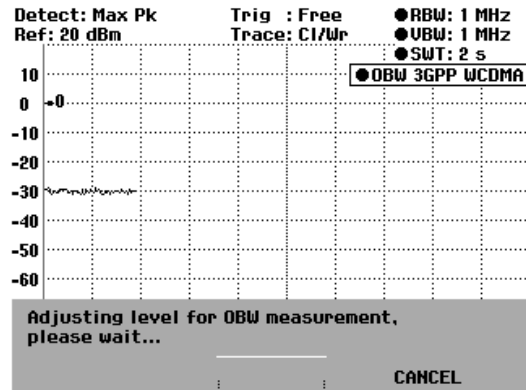

## Setting the channel bandwidth

The channel bandwidth determines the span, resolution bandwidth and sweep time the R&S FSH3-TV uses for measuring the occupied bandwidth.

- Press the CHAN BW softkey.

An entry box showing the current channel bandwidth setting opens.

- Using the numeric keys, enter a new channel bandwidth and terminate the entry with the appropriate unit; or
- Change the channel bandwidth with the rotary knob or the cursor keys and terminate the entry with the ENTER key or the CHANNEL BW softkey.

The R&S FSH3-TV automatically adapts the span to the channel bandwidth that has been entered (span = 5 x channel bandwidth) to ensure that no incorrect measurements of occupied bandwidth are made. The minimum channel bandwidth that can be set is 2 kHz. If you attempt to enter a smaller channel bandwidth, the R&S FSH3-TV will automatically set 2 kHz and output the message "Limit exceeded".

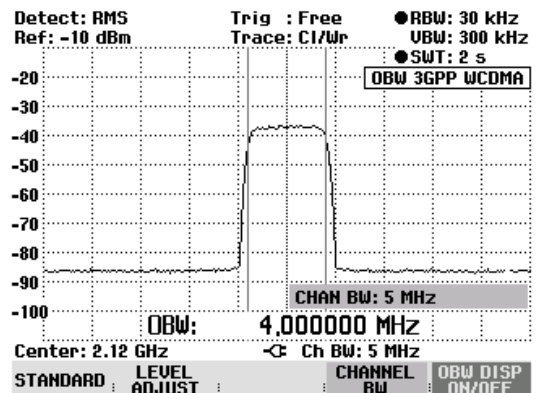

## Displaying the occupied bandwidth

The R&S FSH3-TV now displays the occupied bandwidth (OBW: nnn.nn kHz) at the bottom of the measurement diagram. Usually the trace is not obscured. However, if the trace is in this area, the display of the occupied bandwidth can be turned off. Simply press the OBW DISP ON/OFF key. If the softkey is highlighted in green, display of the occupied bandwidth is on.

## Changing the span

The span set by the R&S FSH3-TV normally yields optimum measurement results. In some cases, however, a larger span needs to be selected. This is the case, for example, when the area outside the span that is automatically set contains signal components that need to be included in the measurement.

### Operation:

- Press the SPAN key.

The AUTO SPAN softkey label is highlighted in green to indicate that the optimum span for measuring the occupied bandwidth is set. MANUAL SPAN entry is active for immediate entry of another span.

- Using the numeric keys, enter a new span and terminate the entry with the appropriate unit, or
- Change the span with the rotary knob or the cursor keys and terminate the entry with the ENTER key or the MANUAL SPAN softkey.

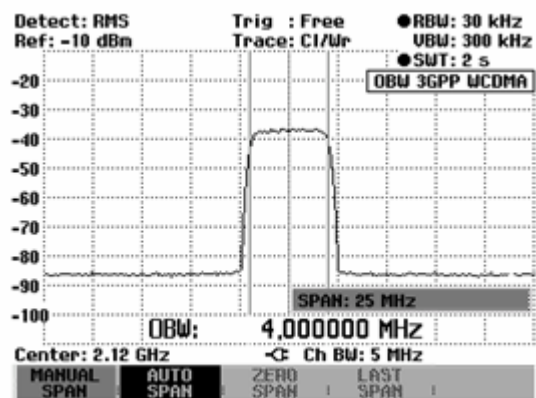

The largest permissible span for measuring the occupied bandwidth is ten times the channel bandwidth. At larger spans, the result of the channel power measurement would be increasingly imprecise, because too few points of the trace occur in the channel to be measured.

- Press the AUTO SPAN softkey to again set the optimum span.
- To return to the menu for measuring the occupied bandwidth, press the MEAS key

## Using the Receiver mode (option R&S FSH-K3)

(only available if option R&S FSH-K3 is installed)

The receiver mode (option R&S FSH-K3) is used for measuring levels on individual frequencies. In this mode, the R&S FSH3-TV functions as a receiver and measures the level on a prescribed frequency. In addition, it is possible to perform measurements on several frequencies with a graphical display of the levels. Unlike the analyzer mode, in which the R&S FSH3-TV sweeps quasi-continuously over the specified frequency range, in the receiver mode the instrument measures on specified discrete frequencies using the selected measurement time per frequency.

Activating the receiver mode:

- Press the MEAS key.
- Press the MEASURE softkey.

The menu for measurement functions opens.

- Use the rotary knob or the cursor keys to select RECEIVER from the menu and confirm with the ENTER key or the MEASURE softkey.

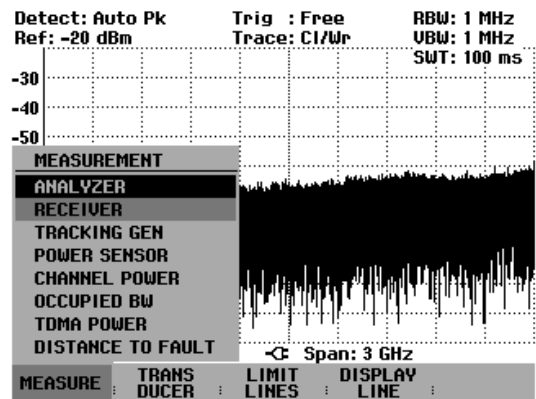

The R&S FSH3-TV activates the receiver mode and measures the level on the set frequency.

Screen layout:

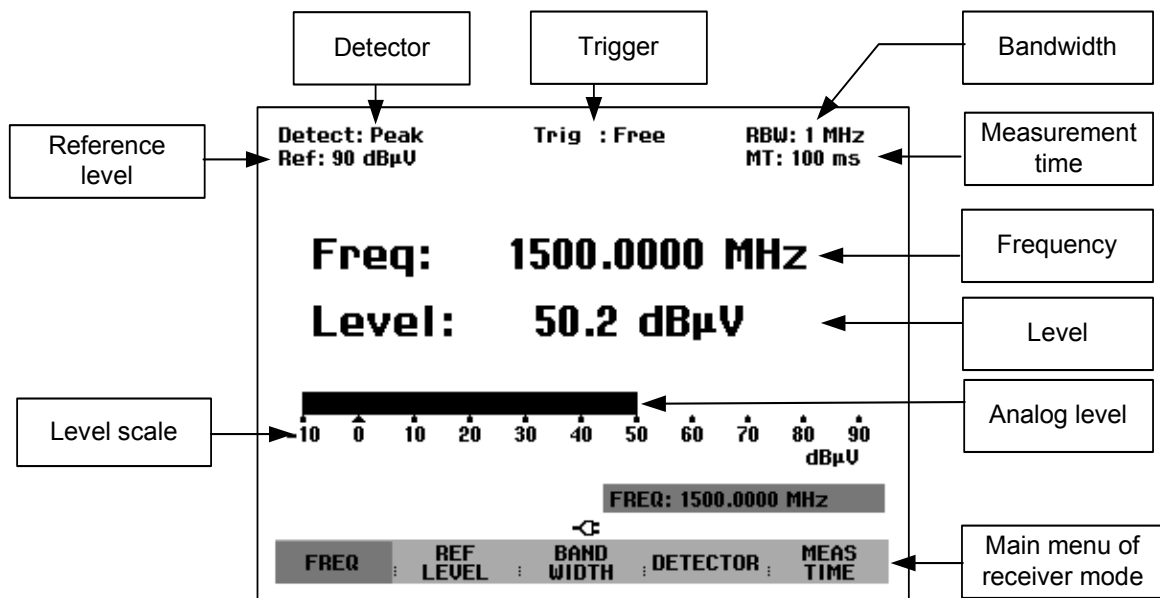

The R&S FSH3-TV provides the most important setting parameters such as frequency, reference level, measurement bandwidth, detector and measurement time in the main menu of the receiver mode. However, the settings can also be made using the corresponding keys.

## Setting the frequency

The frequency is set either in the main menu of the receiver mode or by using the FREQ key.

Frequency entry is active immediately after the receiver mode has been called. The receiving frequency can be changed with the rotary knob, the cursor keys or by entering a numeric value.

If the R&S FSH3-TV is not in the main menu, the receiving frequency can be changed as follows:

- Press the MEAS key.

Frequency entry is activated. The frequency entry box is displayed, and the frequency can be changed directly.

Alternatively the frequency can be entered via the FREQ key.

- Press the **FREQ** key.

The R&S FSH3-TV switches to the frequency menu and activates frequency entry.

- Change the receiving frequency with the rotary knob or the cursor keys, or enter a new receiving frequency via the numeric keypad.

The frequency is displayed immediately after the entry.

**Setting the frequency stepsize:**

The stepsize for tuning the frequency with the rotary knob can be specified. The default tuning stepsize is 100 Hz, matching the minimum frequency resolution in the receiver mode. The tuning stepsize with the cursor keys is always 100 kHz.

- Press the **FREQ** key.
- Press the **FREQ STEPSIZE** softkey.
- Select the desired stepsize (100 Hz, 1 kHz, 10 kHz, 100 kHz or 1 MHz) in the menu for the stepsize.
- Confirm your selection with the **ENTER** key or by pressing the **FREQ STEPSIZE** softkey again.
- For stepsizes other than those offered, select **MANUAL...** from the menu and confirm with the **ENTER** key or the **FREQ STEPSIZE** softkey.
- Enter the desired stepsize in the entry box using the numeric keypad and terminate the entry with the required unit key. Alternatively the stepsize can be changed with the rotary knob or the cursor keys.

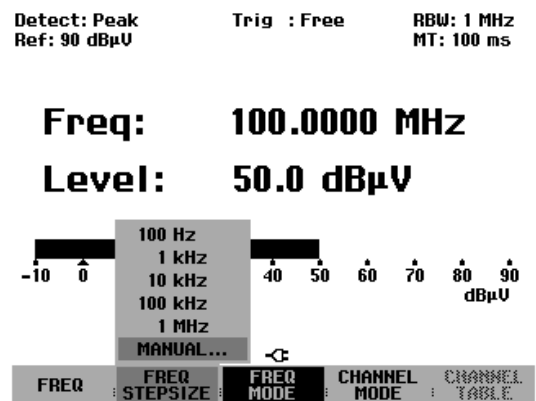

**Frequency tuning in channel spacings:**

For measurement in channel spacings, it is possible to enter a frequency channel instead of the frequency. A simple channel table can be defined directly from the R&S FSH3-TV's front panel. Complicated channel tables, e.g. ones with gaps in the channel numbers or the frequency, must be defined using the R&S FSH View software and loaded into the R&S FSH3-TV's memory.

- Press the **FREQ** key.
- Press the **CHANNEL MODE** softkey.

The R&S FSH3-TV now displays, instead of the frequency, a channel according to the channel table that was just switched on.

A channel table is selected as follows:

- Press the **CHANNEL TABLE** softkey.

The R&S FSH3-TV switches to the submenu for selecting the channel configuration. All channel tables available in the instrument that were loaded with the R&S FSH View software are displayed. If no channel table is loaded, "No bands available" is displayed.

- Select the desired channel table using the rotary knob or the cursor keys.
- Confirm your selection with the **SELECT** softkey.

30/03/2004	BAND TABLE LIST	22:10:16
	<b>TU France</b>	01/03/2004 15:59:02
	TU Japan	01/03/2004 14:58:52
	TU DK_OIRT	01/03/2004 14:40:20
	TU Australia	01/03/2004 14:40:08
	TU Europe	01/03/2004 14:39:56
	TU China	01/03/2004 14:34:40
	TU Italy	01/03/2004 14:30:40
	TU Ireland	01/03/2004 14:30:26
	TU French Overs	01/03/2004 14:30:16
	PCS UL	01/01/1995 02:00:00
	PCS DL	01/01/1995 02:00:00
	GSM UL	01/01/1995 02:00:00
	GSM DL	01/01/1995 02:00:00

SELECT	SELECT USER TAB	EXIT	DEFIN USER TAB	LIST-> PRINTER
--------	-----------------	------	----------------	----------------

The R&S FSH3-TV switches to the frequency entry menu. The frequency is displayed as channels, and the **FREQ** softkey is replaced by **CHANNEL**. All frequencies are now entered as channel numbers. The R&S FSH3-TV only accepts entries that are defined in the channel list. Other frequencies can no longer be entered.

The frequency associated with the set channel is additionally displayed above the displayed channel.

- Set a new channel using the rotary knob or the cursor keys or enter a new channel via the numeric keypad.

If you try to enter a channel outside of the defined range, the R&S FSH3-TV displays "Range exceeded".

If no channel table is stored in the instrument or a different one is necessary, a user table can also be defined.

Detect: Peak      Trig : Free      RBW: 1 MHz  
 Ref: 90 dBµV      MT: 100 ms  
 Freq: 64.5000 MHz

**Channel: 4 (VHF 1)**  
**Level: 51.4 dBµV**

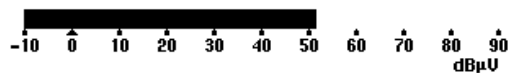

CHANNEL: 4			
CHANNEL	FREQ STEPSIZE	FREQ MODE	CHANNEL MODE
			CHANNEL TABLE

To define a user table, proceed as follows:

- Press the **FREQ** key.
- Press the **CHANNEL TABLE** softkey.
- Press the **SELECT USER TAB** softkey.
- Press the **DEFINE USER TAB** softkey.

The R&S FSH3-TV opens the submenu for entering the different parameters of the channel table. A channel table is defined by the number used for the first channel and the associated frequency, and by the number of channels and their frequency spacing.

30/03/2004	BAND TABLE LIST	22:15:14
TU France	01/03/2004 15:59:02	
TU Japan	01/03/2004 14:58:52	
TU DK_OIRT	01/03/2004 14:40:20	
TU Australia	01/03/2004 14:40:08	
<b>TU Europe</b>	<b>01/03/2004 14:39:56</b>	
TU China	01/03/2004 14:34:40	
TU Italy	01/03/2004 14:30:40	
TU Ireland	01/03/2004 14:30:26	
TU French Overs	01/03/2004 14:30:16	
PCS UL	01/01/1995 02:00:00	
PCS DL	01/01/1995 02:00:00	
GSM UL		1ST CHANNEL NO...
GSM DL		1ST CHANNEL FREQ...
		NO OF CHANNELS...
		CHANNEL SPACING...
SELECT	SELECT USER TAB	EXIT
		DEFINE USER TAB
		LIST-> PRINTER

- Select 1<sup>ST</sup> CHANNEL NO... by pressing the **ENTER** key.
- Enter the number of the first channel and confirm the entry with the **ENTER** key.
- Press the **DEFINE USER TAB** softkey.
- Select 1<sup>ST</sup> CHANNEL FREQ... from the menu and confirm with the **ENTER** key.
- Enter the frequency of the first channel and terminate the entry with the frequency unit.
- Press the **DEFINE USER TAB** softkey.
- Select NO OF CHANNELS... from the menu and confirm with the **ENTER** key.
- Enter the number of channels and confirm the entry with the **ENTER** key.
- Press the **DEFINE USER TAB** softkey.
- Select CHANNEL SPACING... from the menu and confirm with the **ENTER** key.
- Enter the channel spacing and terminate the entry with the required unit key.

## Setting the reference level

The reference level is set either in the receiver main menu or by using the AMPT key. This level is the maximum level of the analog bar graph display.

Set the reference level such that the analog bar graph display is within its scale. However, make sure the reference level is so low that the measurement signal does not disappear in the inherent noise. This can be checked, for example, by removing the input signal.

### Setting the reference level in the main menu of the receiver mode:

- Press the MEAS key.
- Press the REF LEVEL softkey.
- Change the reference level setting with the cursor keys or the rotary knob, or enter a new reference level via the numeric keypad.
- Confirm the entry of the reference level by pressing the ENTER key.

### Setting the reference level in the amplitude menu:

- Press the AMPT key.
- Press the REF LEVEL softkey.
- Change the reference level setting with the cursor keys or the rotary knob, or enter a new reference level via the numeric keypad.
- Confirm the entry of the reference level by pressing the ENTER key.

## Setting the bandwidth

The same bandwidths available in the analyzer mode are also available in the receiver mode. In addition, the R&S FSH3-TV provides the bandwidths 200 Hz, 9 kHz, 120 kHz and 1 MHz for measuring electromagnetic interference according to CISPR16. In contrast to the analyzer bandwidths, which are defined as 3 dB bandwidths, the CISPR bandwidths are 6 dB bandwidths.

- Press the BW key.

The R&S FSH3-TV immediately activates entry of the resolution bandwidth (the MANUAL RES BW softkey is highlighted in red).

- Change the current bandwidth with the cursor keys or the rotary knob, or enter a new bandwidth via the numeric keypad and terminate the entry with the required unit key.

*Note: The 200 kHz bandwidth must always be entered via the numeric keypad.*

CISPR16 bandwidths must be set as follows:

- Press the MANUAL CISPR BW softkey in the BW menu.
- Select one of the CISPR bandwidths using the cursor keys or the rotary knob.
- Confirm with the ENTER key.

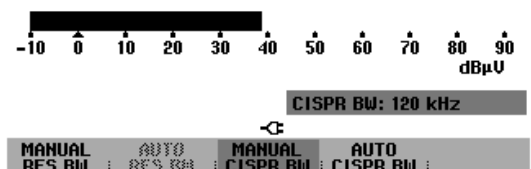

The bandwidths 200 Hz, 9 kHz, 120 kHz and 1 MHz are available.

The CISPR bandwidths are predefined for specific frequency ranges as follows according to CISPR16:

Frequency range	Bandwidth
<150 kHz	200 Hz
150 kHz to 30 MHz	9 kHz
30 MHz to 1000 MHz	120 kHz
>1000 MHz	1 MHz

For this purpose, the R&S FSH3-TV automatically sets the predefined bandwidth as a function of the selected frequency.

- Press the BW key.
- Press the AUTO CISPR BW softkey.

### Setting the detector

The following detectors are available in the receiver mode:

- Peak**                      The peak detector displays the highest level during the set measurement time.
- Average**                The average detector displays the linear average of the measurement signal within the selected measurement time.
- RMS**                      The RMS detector takes the rms value of the measurement signal during the set measurement time.
- Quasi-peak**            The quasi-peak detector evaluates the measurement signal according to the evaluation curves defined in the CISPR16 standard. The R&S FSH3-TV uses three different evaluation curves that are coupled to the set bandwidth. For frequencies below 150 kHz (CISPR band A), the R&S FSH3-TV sets the 200 Hz bandwidth. The evaluation for band B (to be used from 150 kHz to 30 MHz) is coupled to the 9 kHz bandwidth. The quasi-peak evaluation for the C/D band (30 MHz to 1000 MHz) is coupled to the 120 kHz bandwidth.

The detector is selected either in the main menu of the receiver mode or by using the TRACE key.

- Press the DETECTOR softkey in the main menu of the receiver mode
- or
- Press the TRACE key and then the DETECTOR softkey.

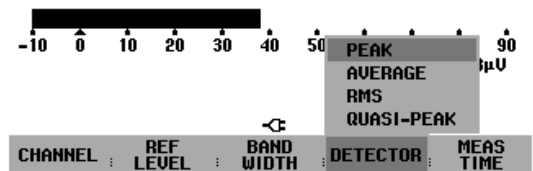

The menu for selecting the detector opens.

- Using the rotary knob or the cursor keys, select the desired detector.
- Confirm your selection with the ENTER key or by pressing the DETECTOR softkey again.



## Setting the measurement time

The measurement time is the time during which the R&S FSH3-TV observes the signal and combines it with the result displayed at the end of the measurement time as a function of the set detector. The R&S FSH3-TV accepts measurement times between 1 ms and 100 s.

- Press the MEAS TIME softkey in the receiver main menu or in the trace menu.
- Change the measurement time in the entry box with the rotary knob or the cursor keys, or enter a new value via the numeric keypad.
- Confirm the entry with the ENTER key.

## Measurement on multiple frequencies or channels (scan)

In a scan, the R&S FSH3-TV sequentially measures the levels in predefined channels and graphically displays the measurement results. The length of time the scan dwells on a frequency is determined by the measurement time. The measurement channels are specified by the selected channel table.

- Press the SPAN key.
- Press the FREQ SCAN softkey.

The FREQ SCAN softkey is highlighted in green to indicate that the R&S FSH3-TV is in the scan mode.

- Confirm the entry with the ENTER key.
- Press the SCAN START softkey.
- Enter the start frequency of the scan via the numeric keypad, or change the start frequency using the rotary knob or the cursor keys.
- Press the STOP SCAN softkey.
- Enter the stop frequency of the scan via the numeric keypad, or change the start frequency using the rotary knob or the cursor keys.
- Press the SCAN STEP softkey.
- Enter the stepsize of the scan via the numeric keypad, or change the start frequency using the rotary knob or the cursor keys.

The R&S now measures on the frequencies defined by the scan parameters. The levels are displayed by vertical lines on each of the frequencies. The height of each line indicates the level.

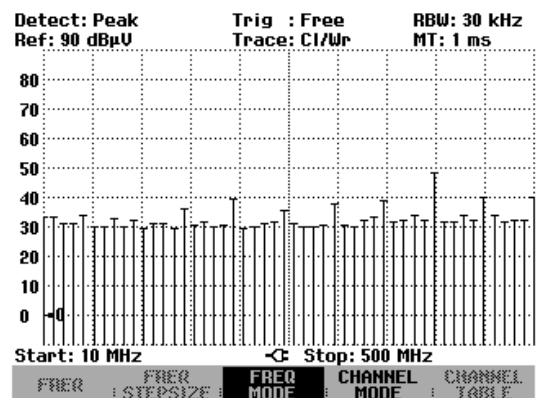

Pressing the FIXED FREQ softkey switches the R&S FSH3-TV back to the default setting of the receiver mode.

A scan is also possible via the channel table. If frequency entry is set to Channel, the R&S FSH3-TV uses the associated channel table.

- Press the **FREQ** key.
- Press the **CHANNEL MODE** softkey.
- Press the **SPAN** key.
- Press the **CHANNEL SCAN** key.

The R&S FSH3-TV now scans across the channels of the active channel table.

The frequency range for the scan is set using the **START SCAN** and **STOP SCAN** softkeys.

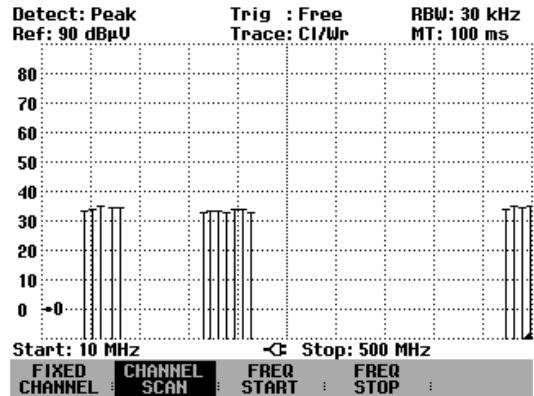

The channel table used can be displayed with the **FREQ** key and the **CHANNEL TABLE** softkey. It is highlighted in red in the table of channel tables.

The screenshot above shows a measurement using a channel table with frequency gaps. Different segments that are not interconnected are specified using the table defined with R&S FSH View. In the default setting, the levels in each of the channels are displayed as vertical lines. Alternatively the R&S FSH3-TV provides a polygon display, in which the level values of the individual channels are interconnected by straight lines.

- Press the **TRACE** key.
- Press the **TRACE STYLE** softkey.
- Select **POLYGON** with the rotary knob or the cursor keys.

The R&S FSH3-TV switches to the polygon display.

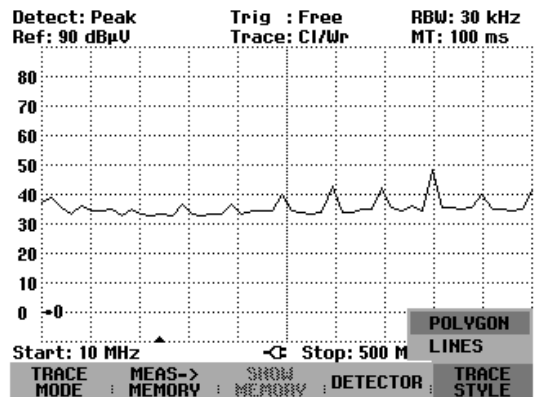

## Working with the Preselector R&S FSHTV-Z60

Available as of FSH3-TV firmware version 9.25 or higher.

The Preselector R&S FSHTV-Z60 improves the dynamic range and the sensitivity of the TV analyzer R&S FSH3-TV for cable TV applications. In the frequency range up to 1.1 GHz, the received signal is attenuated by an electronic attenuator, selected by one of four filters and amplified. Due to the bandwidth reduction in the received signal, the total power at the input mixer is reduced which produces a significant reduction in the intermodulation products which arise in the R&S FSH3-TV. This results in an improved dynamic range.

By amplifying the input signal after filtering, the total noise figure is reduced. This results in improved sensitivity.

The following table provides a summary of the bandwidth reduction achieved with the Preselector R&S FSHTV-Z60.

Frequency range	Filter	3 dB bandwidth	10 dB bandwidth
$\leq 108$ MHz	Lowpass filter	140 MHz	150 MHz
$> 108$ MHz to $< 250$ MHz	Tracking filter	45 MHz	75 MHz
$\geq 250$ MHz to $< 600$ MHz	Tracking filter	75 MHz	120 MHz
$\geq 600$ MHz to $\leq 1100$ MHz	Tracking filter	170 MHz	300 MHz

For measurements over 1.1 GHz and fast sweeps with a wide frequency span, the filter branch is bypassed completely.

To increase the sensitivity at low receive levels, a low-noise amplifier can be connected after the filter branch as well as after the bypass branch.

The RF input to the preselector is implemented as a precision F connector with a  $75 \Omega$  input impedance. The (included) RF adapter F (female) – F (female) R&S FSHTV-Z61 is screwed onto the built-in F connector. The RF adapter R&S FSHTV-Z61 protects the built-in RF connector against wear and tear. The built-in connector and the adapter are both guaranteed for 1000 connection cycles.



## Automatic detection of the preselector

The Preselector R&S FSHTV-Z60 is controlled and supplied with power via the R&S FSH3-TV's control interface jack. The R&S FSH3-TV automatically detects when a preselector is connected or removed. However, **AUTO DETECT** must be set in the menu Setup / Hardware Setup / Accessory.

- Press the SETUP key.
- Press the HARDWARE SETUP softkey.
- Select ACCESSORY... with the rotary knob or the cursor keys.
- Confirm the entry with the ENTER key or the HARDWARE SETUP softkey.
- Select AUTO DETECT with the rotary knob or the cursor keys.
- Confirm the entry with the ENTER key or the HARDWARE SETUP softkey.



The R&S FSH3-TV will automatically detect the connected preselector. It will interrupt the current measurement and display a corresponding message.

- Press the OK softkey to restart the measurement.

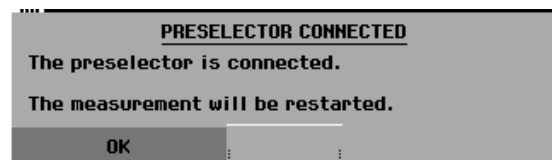

## Automatic calibration

To provide automatic calibration of the gain in the filter path, a calibration generator is built into the preselector. The individual calibration data for the preselector are saved along with the serial number of the preselector in the R&S FSH3-TV. The R&S FSH3-TV automatically takes into account the individual frequency response of the preselector which is connected in the measurement results.

If no calibration data have yet been saved in the R&S FSH3-TV for the connected preselector, the R&S FSH3-TV displays a corresponding message.

To record the calibration data, the calibration routine must be launched.

- Screw the preselector onto the RF input of the R&S FSH3-TV.
- The RF input of the Preselector R&S FSHTV-Z60 must be open.
- Press the CONTINUE softkey.

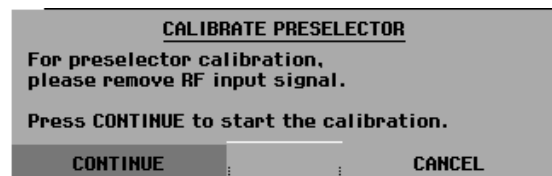

The calibration routine will run automatically. The calibration process takes about four minutes. The current status is displayed during the calibration process.

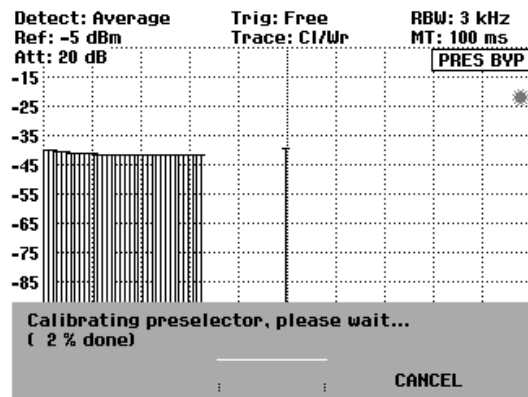

A message indicating that the calibration routine is complete is displayed.

- Press the YES softkey to save the calibration data that were determined for the preselector in the R&S FSH3-TV.

During the calibration process, the frequency response of the preselector is checked to ensure that it complies with the specifications. If it does not, then an appropriate message is displayed with an error number.

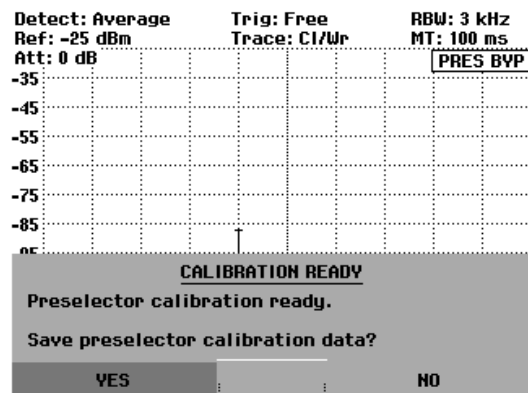

**Manually launching the calibration process**

You can also launch the calibration routine if a calibration data set is already saved in the R&S FSH3-TV for this preselector. This is useful, for example, if you want to make precision measurements under extreme climatic conditions.

- Press the SETUP key.
- Press the HARDWARE SETUP softkey.
- Select PRESELECTION... with the rotary knob or the cursor keys.
- Confirm the entry with the ENTER key or the HARDWARE SETUP softkey.

The PRESELECTION menu should open.

- Select CALIBRATE with the rotary knob or the cursor keys.
- Confirm the entry with the ENTER key or the HARDWARE SETUP softkey.

The calibration routine should begin.

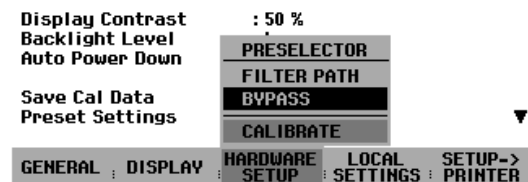

## Selecting the signal path

The filter path of the Preselector R&S FSHTV-Z60 covers the frequency range up to 1100 MHz. For measurements over 1100 MHz and fast sweeps with a wide frequency span, the filter branch can be completely bypassed.

- Press the SETUP key.
- Press the HARDWARE SETUP softkey.
- Select PRESELECTOR... with the rotary knob or the cursor keys.
- Confirm the entry with the ENTER key or the HARDWARE SETUP softkey.



The PRESELECTOR menu should open.

- Select the desired signal path with the rotary knob or the cursor keys.
- Confirm the entry with the ENTER key or the HARDWARE SETUP softkey.

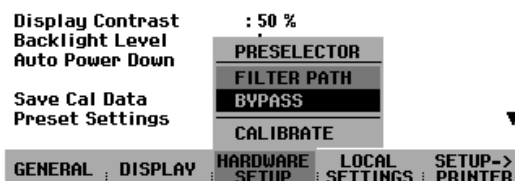

## Attenuator control

The preselector's filter path contains an RF attenuator which is set depending on the setting for the reference level and the selected dynamic range.

There is no separate RF attenuator in the preselector's bypass path. The RF attenuator in the R&S-FSH3-TV is used for attenuation purposes.

The following table shows the RF attenuation when the preamplifier is switched off.

RF attenuation	Preamplifier OFF			
	Bypass path		Filter path	
	Low noise	Low distortion	Low noise	Low distortion
Ref Level				
≤ -25 dBm	0 dB	0 dB	0 dB	0 dB
-24 to -20 dBm	0 dB	0 dB	0 dB	5 dB
-19 to -15 dBm	0 dB	0 dB	0 dB	10 dB
-14 to -10 dBm	0 dB	0 dB	5 dB	15 dB
-9 to -5 dBm	0 dB	10 dB	10 dB	20 dB
-4 to 0 dBm	0 dB	10 dB	15 dB	25 dB
1 to 5 dBm	10 dB	20 dB	20 dB	30 dB
6 to 10 dBm	10 dB	20 dB	25 dB	30 dB
11 to 15 dBm	20 dB	30 dB	30 dB	30 dB
16 to 20 dBm	20 dB	30 dB	30 dB	30 dB

## Working with the preamplifier

To boost the sensitivity, the Preselector R&S FSHTV-Z60 contains a preamplifier which provides 15 dB to 18 dB of gain depending on the frequency. It is located at the output of the preselector.

- Press the SETUP key.
- Press the HARDWARE SETUP softkey.
- Select PREAMP... with the rotary knob or the cursor keys.
- Confirm the entry with the ENTER key or the HARDWARE SETUP softkey.

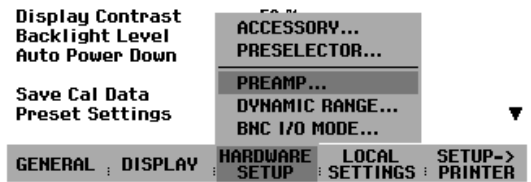

The PREAMPLIFIER menu should open.

- Using the rotary knob or the cursor keys, select the desired setting (ON or OFF) and confirm your selection by pressing the ENTER key.

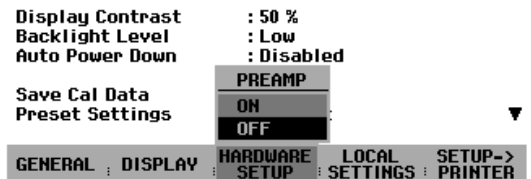

When the preamplifier is switched on, its usage is linked to the setting for the reference level and the selected signal path so that R&S FSH3-TV is always assured the best possible dynamic range. The preamplifiers in the preselector and in the R&S FSH3-TV are added on in stages. The following table shows the settings for the RF attenuator and the preamplifiers depending on the reference level.

RF attenuation Ref Level	Preamplifier ON					
	Bypass path			Filter path		
	RF attenuation FSH3-TV	Preamp FSH3-TV	Preamp FSHTV-Z60	RF attenuation FSHTV-Z60	Preamp FSH3-TV	Preamp FSHTV-Z60
≤ -45 dBm	0 dB	ON	ON	0 dB	ON	ON
-44 to -30 dBm	0 dB	ON	ON	0 dB	ON	OFF
-29 to -25 dBm	0 dB	ON	OFF	5 dB	ON	OFF
-24 to -20 dBm	0 dB	ON	OFF	10 dB	ON	OFF
-19 to -15 dBm	0 dB	ON	OFF	0 dB	OFF	OFF
-14 to -10 dBm	0 dB	OFF	OFF	5 dB	OFF	OFF
-9 to -5 dBm	0 dB	OFF	OFF	10 dB	OFF	OFF
-4 to 0 dBm	0 dB	OFF	OFF	15 dB	OFF	OFF
1 to 5 dBm	10 dB	OFF	OFF	20 dB	OFF	OFF
6 to 10 dBm	10 dB	OFF	OFF	25 dB	OFF	OFF
11 to 15 dBm	20 dB	OFF	OFF	30 dB	OFF	OFF
16 to 20 dBm	20 dB	OFF	OFF	30 dB	OFF	OFF

## Measurements using the power sensor

For even more accurate power measurements, the R&S FSH3-TV can be used with the Power Sensors R&S FSH-Z1 and R&S FSH-Z18. Their frequency ranges are 10 MHz to 8 GHz and 10 MHz to 18 GHz, respectively. This means that both sine signals and modulated signals can be measured precisely over a large dynamic range.

### Connecting the power sensor

The Power Sensors R&S FSH-Z1 and -Z18 are controlled and powered via a special interface. Connect the power sensor cable to the R&S FSH3-TV's power sensor connector and screw into position. The DUT is connected to the N-connector on the power sensor.

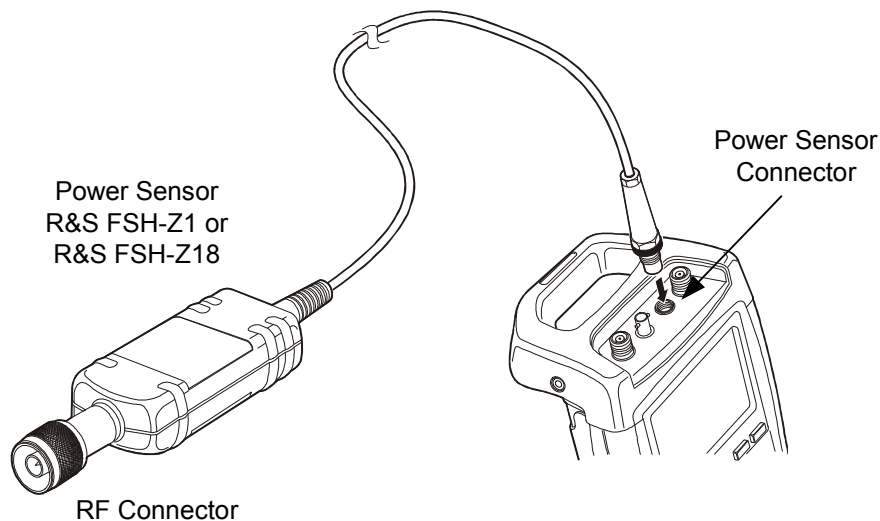

*The continuous power applied to the power sensor's input must not exceed 400 mW (26 dBm). Short ( $\leq 10 \mu\text{s}$ ) power peaks up to 1 W (30 dBm) are however permissible. Higher input powers may destroy the sensor. An attenuator pad must be used to ensure that the maximum permissible power for the sensor is never exceeded when measurements are made on high-power transmitters.*

### Measurement:

The POWER SENSOR function turns the R&S FSH3-TV into a wideband power meter. Then, it always measures the power of the whole signal from 10 MHz to 8 GHz or from 10 MHz to 18 GHz, in most cases the signal shape having no effect on the measurement.



**Operating sequence:**

- Press the MEAS key.
- Press the MEASURE softkey.

The measurement function submenu opens.

- Using the cursor keys or the rotary knob, select the POWER SENSOR menu item and confirm your selection with the ENTER key or the MEASURE softkey.

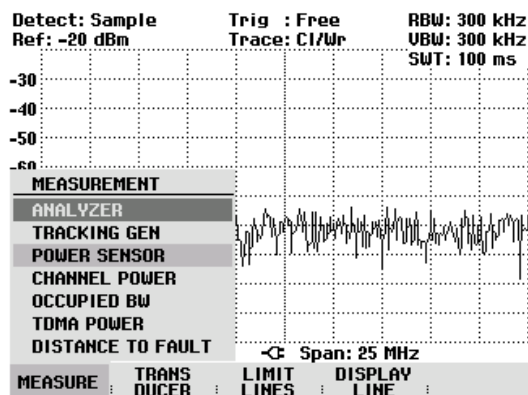

The R&S FSH3-TV opens the screen for power measurements. If no power sensor is connected, no measured value is displayed. If a power sensor is connected, the R&S FSH3-TV sets up a connection via its interface and after a few seconds displays the measured power.

In the event of incorrect operation or sensor malfunction, the R&S FSH3-TV outputs the following error messages:

Message	Cause	Remedy
Error in zeroing: signal at sensor	A signal was present at the power sensor when zeroing was performed.	Unscrew the power sensor from the device under test and repeat zeroing.
Warning: Input overloaded	The power at the input of the power sensor exceeds the permitted power (23 dBm = 200 mW).	Reduce the power at the sensor input.
Power sensor hardware error	Communication error between the R&S FSH3-TV and the power sensor.	Unscrew the sensor from the R&S FSH3-TV and check the connectors. If the problem persists, contact a Rohde & Schwarz service center.
Power sensor error	The power sensor signals an error to the R&S FSH3-TV.	Contact a Rohde & Schwarz service center.
Unknown power sensor model connected	The R&S FSH3-TV cannot identify the device connected to its POWER SENSOR connector.	

Screen layout for power-sensor measurements:

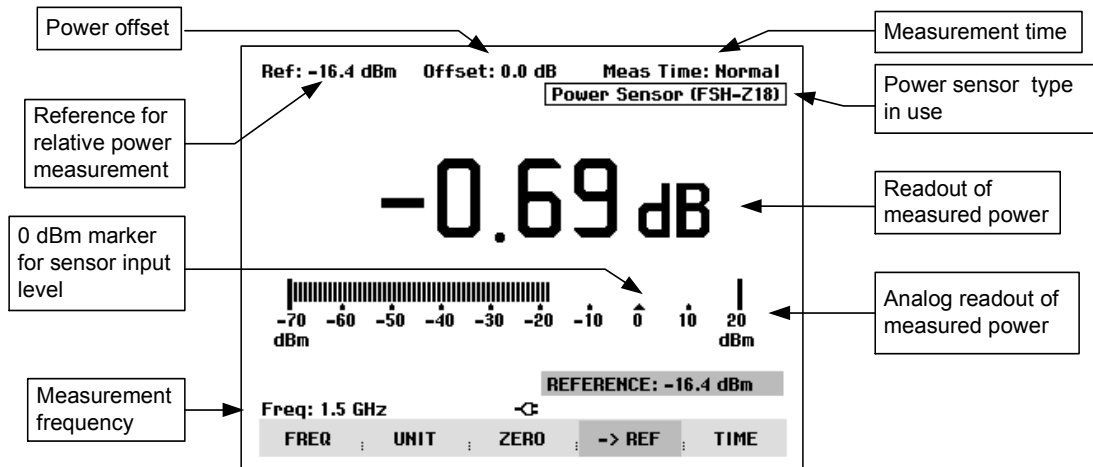

The power sensor has a memory containing frequency-dependent correction values. This means that the highest accuracy is reached for signals whose frequency is known. If the R&S FSH3-TV switches over to the power measurement mode from another operating mode, it uses the center frequency as the frequency for the power sensor.

If you want to perform measurements on another known signal, the power sensor can be “told” what the center frequency is via the frequency entry mode (FREQ softkey).

- Press the FREQ softkey.

The frequency value entry box opens.

- Using the number keys, enter the frequency you want and confirm the entry with the ENTER key or by pressing the FREQ softkey again.

The R&S FSH3-TV transfers the new frequency to the power sensor which then corrects the measured power readings.

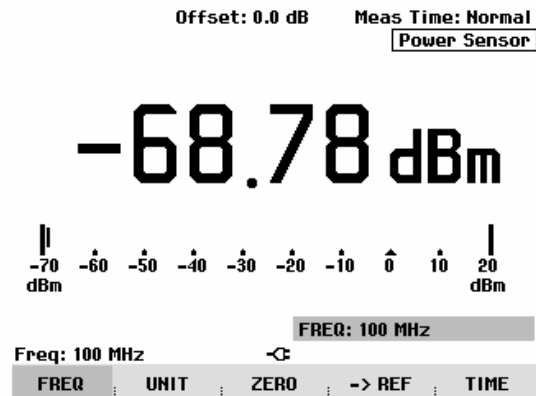

## Zeroing the power sensor

Offset voltages and currents have most effect on the power readout when low powers are being measured. Zeroing is used to compensate for these offsets. The power sensor zeroes itself automatically when instructed to do so by the user. No power may be applied when zeroing is being performed, as the power sensor cannot distinguish between external powers and internal offsets.

- Press the ZERO softkey.

The R&S FSH3-TV outputs a message to tell the user not to apply any signals to the power sensor when zeroing is being performed.

- Disconnect the power sensor from any signal sources.
- Start zeroing with the first or second softkey (CONTINUE).

Softkeys 4 or 5 (CANCEL) can be used to abort zeroing, if, for example, a signal source cannot be disconnected.

The R&S FSH3-TV immediately starts power sensor zeroing. While zeroing is in progress, the R&S FSH3-TV outputs the message “Zeroing power sensor, please wait..”.

When zeroing is over, the R&S FSH3-TV outputs the message "Power sensor zero OK" and switches back to the softkey menu for the power sensor.

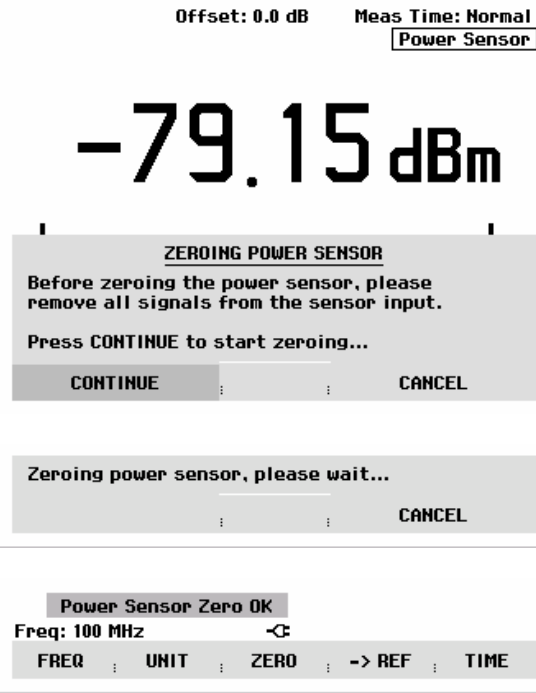

## Selecting the unit for the power readout

The R&S FSH3-TV can display measured power in relative units (dBm) or in absolute units in Watts (W, mW,  $\mu$ W, nW and pW). A reference level in dB is also provided by the R&S FSH3-TV.

- Press the UNIT softkey.

The units submenu then opens.

- Using the rotary knob or the cursor keys select the appropriate unit.
- Confirm with the ENTER key or the UNIT softkey.

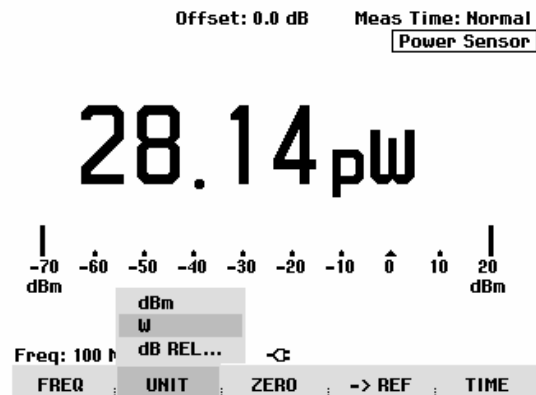

If the unit dB REL... has been selected, the reference level value entry box opens.

- Enter the reference level (REFERENCE) with the number keys and terminate entry with the appropriate unit or change the reference level using the rotary knob or cursor keys.

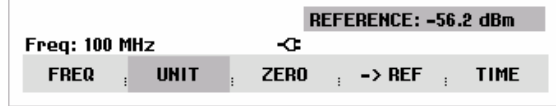

The current level reading can be made the reference level by just pressing the ->REF softkey.

- Press the ->REF softkey.

The R&S FSH3-TV sets the current measured level as the reference level and from then on displays the measured level relative to the reference level in dB. The unit (UNIT) is automatically set to dB REL... .

The reference level is shown in the top left-hand corner of the screen (in this case Ref: -10.4 dBm).

In the REFERENCE value entry box, the reference level can be adjusted with the rotary knob or the cursor keys or corrected by making a numeric entry.

- Confirm the reference level with the ENTER key or by pressing the ->REF softkey.

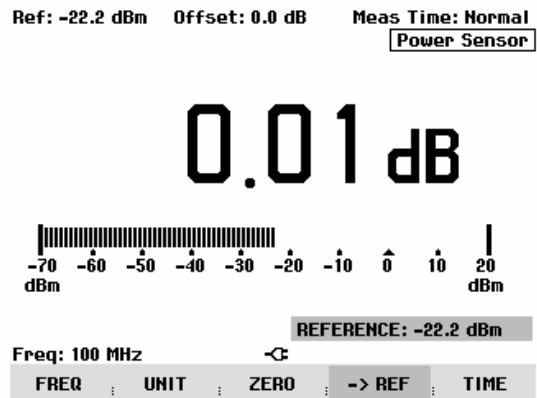

## Setting the averaging time

The averaging time determines how long the signal will be measured for. The longer the averaging time, the more stable the display – particularly if signals are at the lower end of the measurement range or are noisy. The R&S FSH3-TV has three times for power measurements: fast, normal and slow.

Stationary sine signals with a high level (> -40 dBm) require only a short measurement time to produce a stable, accurate result. In this case, the FAST operating mode is recommended to obtain a high repetition rate for the measurement. When the NORMAL setting is selected, the stability of the display is increased for signals with low levels or for modulated signals. The LONG mode is recommended for signals at the lower end of the measurement range (<-50 dBm to <-60 dBm). The R&S FSH-Z1 averages out the noise most effectively and the effect of noise on the measurement is minimal.

- Press the TIME softkey.
- Using the rotary knob or the cursor keys select the measurement time you want from the menu (i.e. SHORT, NORMAL or LONG).
- Confirm your selection with the ENTER key or by pressing the TIME softkey again.

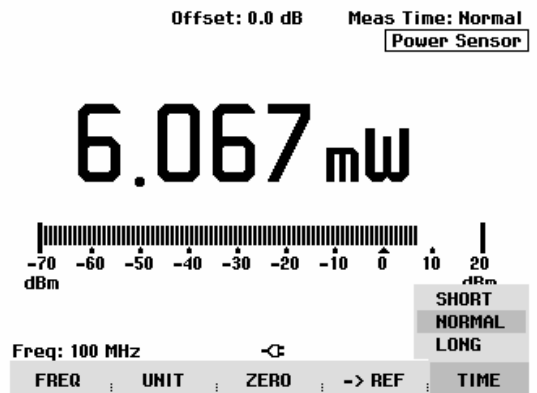



When measuring high powers, strictly observe the following instructions to prevent damage to the sensor or hazard to persons:



- The permissible continuous power at the input of the directional power sensor must in no case be exceeded (see diagram on the rear of the sensor).
- Make sure that the RF power is switched off before connecting the sensor.
- Make sure that the RF connectors are tightly screwed.

Failure to comply with these instructions may cause injuries like burns to the skin or may damage or even destroy the equipment used.

**Operating sequence:**

- Press the MEAS key.
- Press the MEASURE softkey.

The measurement functions submenu opens.

- Using the cursor keys or the rotary knob, select the POWER SENSOR menu item and confirm with the ENTER key or the MEASURE softkey.

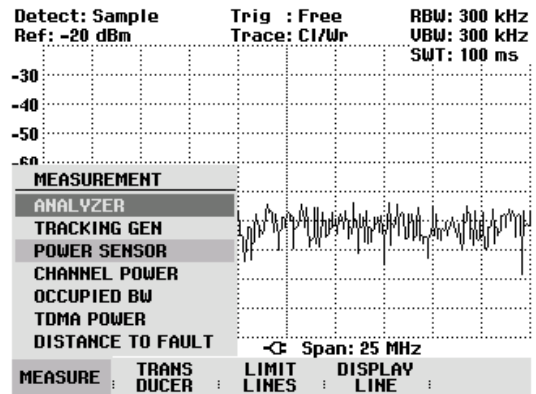

The R&S FSH3-TV opens the screen for power measurements. If no power sensor is connected, it does not display any measured value and outputs **Power Sensor (unknown)** in the status field. If a power sensor is connected, the R&S FSH3-TV sets up a connection via its interface, displays first the message **Power Sensor (Detecting)** and then the message **Power Sensor (Booting)** in the status field and, after a few seconds, displays the type of the sensor connected (R&S FSH-Z44) as well as the measured power.

In the event of incorrect operation or sensor malfunction, the R&S FSH3-TV outputs the following error messages:

Message	Cause	Remedy
Error in zeroing: signal at sensor	A signal was present at the power sensor when zeroing was performed.	Unscrew the power sensor from the device under test and repeat zeroing.
Warning: input overloaded	The power at the input of the power sensor exceeds the permissible power.	Reduce the power at the sensor input.
Hardware error	Communication error between the R&S FSH3-TV and the power sensor.	Unscrew the sensor from the R&S FSH3-TV and check the connectors. If the problem persists, contact a Rohde & Schwarz service center.
Power sensor error	The power sensor signals an error to the R&S FSH3-TV.	Contact a Rohde & Schwarz service center.

Screen layout for measurements with Directional Power Sensors R&S FSH-Z14 and R&S FSH-Z44:

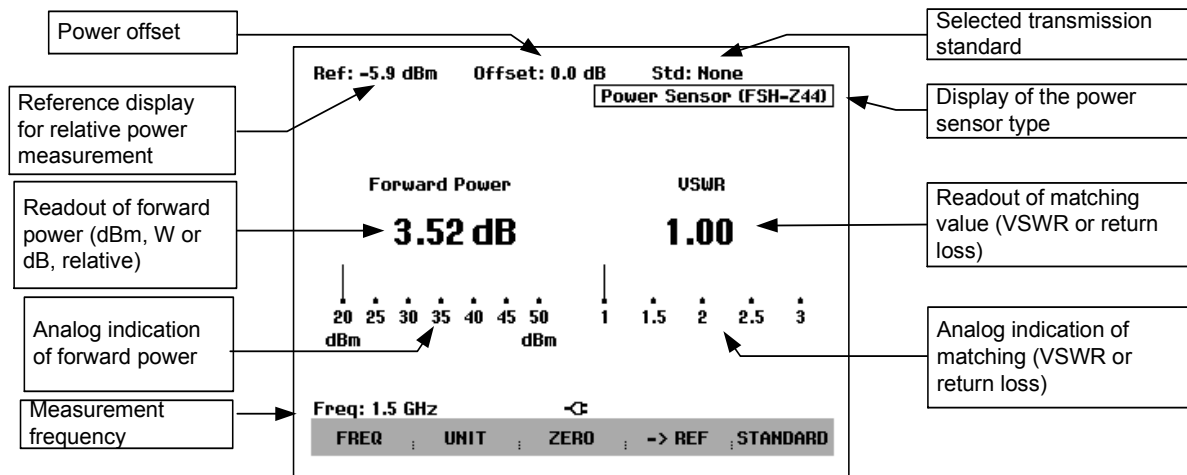

The power sensors contain frequency-dependent correction values. This means that the highest accuracy is reached for signals whose frequency is known. When the R&S FSH3-TV switches to the power measurement mode from another operating mode, it transfers its current center frequency to the power sensor.

If a signal at another frequency is to be measured, the new center frequency can be transferred to the power sensor by entering the frequency (FREQ softkey).

- Press the FREQ softkey.

The frequency value entry box opens.

- Using the number keys, enter the frequency you want and confirm the entry with the ENTER key or by pressing the FREQ softkey again.

The R&S FSH3-TV transfers the new frequency to the power sensor which corrects the measured power values accordingly.

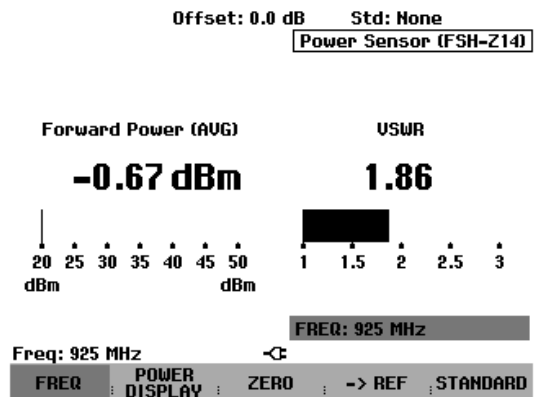

## Zeroing the power sensor

Offset voltages and currents have the greatest effect on the power readout when low powers are being measured. Zeroing is used to compensate for these offsets. The power sensor automatically performs zeroing when the corresponding function is activated by the user. No power must be applied to the sensor while zeroing is being performed, since the sensor cannot distinguish between external powers and internal offsets.

- Press the ZERO softkey.

The R&S FSH3-TV outputs a message to inform the user that no signal should be present at the power sensor input while zeroing is being performed.

- Disconnect the power sensor from any signal sources.
- Start zeroing by pressing CONTINUE (first or second softkey).

Zeroing can be aborted before it is started by pressing CANCEL (4th or 5th softkey), for example if a signal source cannot be disconnected.

The R&S FSH3-TV immediately starts zeroing the power sensor after CONTINUE is pressed. While zeroing is in progress, the message "Zeroing power sensor, please wait..." is displayed on the R&S FSH3-TV.

When zeroing is completed, the R&S FSH3-TV outputs the message "Power Sensor Zero OK" and switches back to the softkey menu for the power sensor.

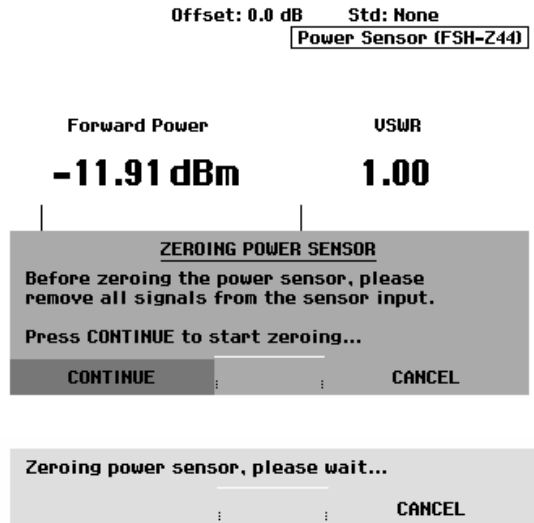

## Setting the power measurement weighting

For forward power display, the R&S FSH3-TV provides both average power and peak envelope power. Use the POWER DISPLAY softkey in the Power Sensor menu to switch between the two.

- Press the POWER DISPLAY softkey.

The menu window for selecting the unit entry for forward power or reflection is opened.

- Select FORWARD POWER from the menu using the rotary knob or the cursor keys.
- Confirm your selection with the ENTER key or by pressing the POWER DISPLAY softkey.

In addition to possible units for the forward power, the R&S FSH3-TV displays the weightings average power and peak envelope power in a submenu. The currently set weighting mode is highlighted in green.

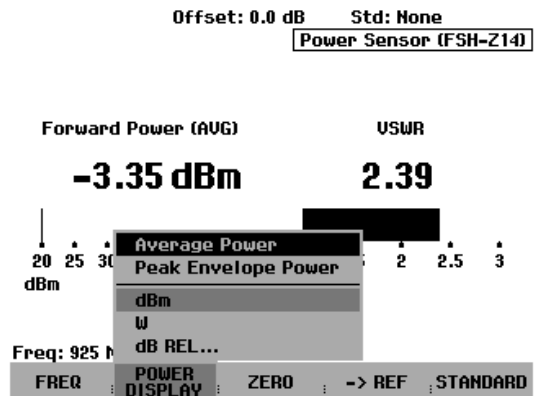

- Select the desired weighting mode using the rotary knob or the cursor keys.
- Confirm your choice with the ENTER key or the POWER DISPLAY softkey.



The R&S FSH3-TV displays the set weighting under the heading forward power on the screen:

Forward power (AVG) = average power

Forward power (PEP) = peak envelope power

### Selecting the unit for the power readout

The R&S FSH3-TV displays the measured forward power as a logarithmic level value in dBm (relative value) or as a linear value in W or mW (absolute value). Moreover, a reference level can be defined relative to which the R&S FSH3-TV indicates the level difference in dB. Load matching is indicated as return loss in dB or as voltage standing wave ratio (VSWR). In addition, the absolutely reflected power can be displayed in W, or the reflected level in dBm.

- Press the POWER DISPLAY softkey.

The menu for selecting the units for forward power and reflected power display opens.

- Using the rotary knob or the cursor keys, select the parameter for which a unit is to be entered.
- Confirm the parameter with the ENTER key or the POWER DISPLAY softkey.

A submenu with the available units opens.

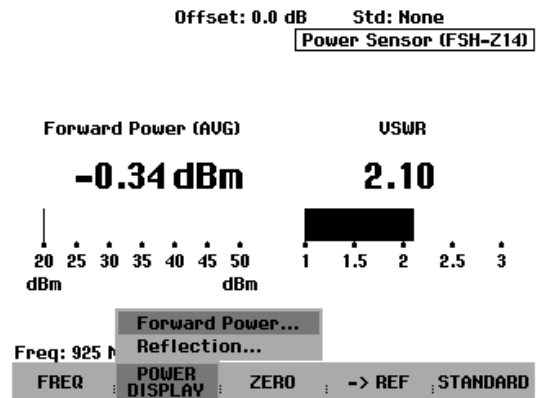

For the forward power, the following units can be selected:

- dBm
- W
- dB REL

For the reflected power or the reflection, the following units can be selected:

- dBm
- W
- VSWR
- dB (return loss)

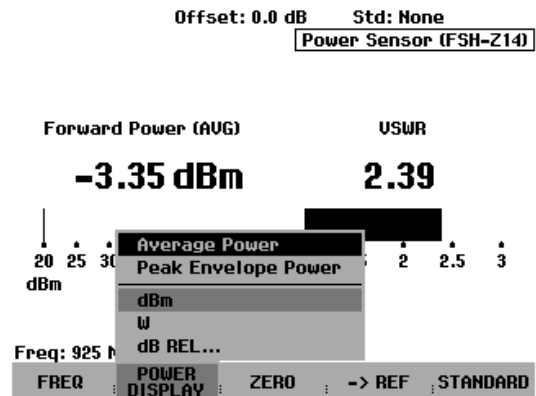

When the dB REL... unit is selected, an entry box for the reference level opens.

- Enter the reference level (REFERENCE) using the number keys and terminate the entry with the appropriate unit, or change the reference level using the rotary knob or the cursor keys.

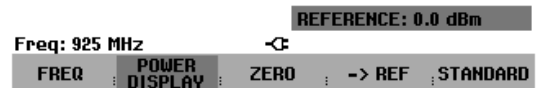

The current level reading can be defined as the reference level simply by pressing the ->REF softkey.

- Press the ->REF softkey.

The R&S FSH3-TV accepts the currently measured level as the reference level and displays the measured level difference relative to the reference level in dB. The unit (UNIT) is automatically set to dB REL...

The reference level is displayed in the upper left corner of the screen (in this case: Ref: -4.8 dBm).

The reference level can be adjusted in the REFERENCE entry box by means of the rotary knob, the cursor keys or the number keys.

- Confirm the reference level with the ENTER key or the ->REF softkey.
- To switch off the relative measurement to absolute values, press the POWER DISPLAY softkey.
- Select the Forward Power... parameter.
- Select dBm or Watt for forward power indication.

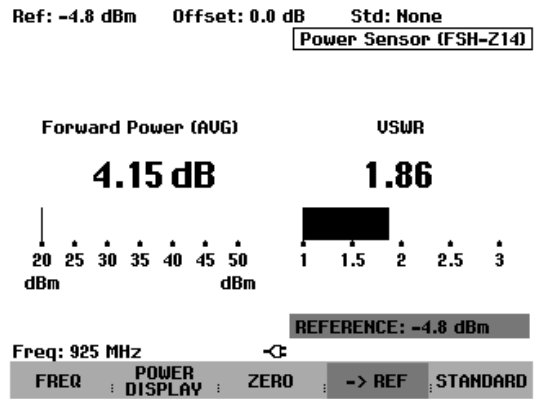

To ensure that true results are output when measuring modulated signals, the R&S FSH3-TV offers the possibility of taking correction values into account for a number of common transmission standards.

- Press the STANDARD softkey.

A menu with the selectable standards opens.

- Select the desired standard using the rotary knob or the cursor keys.
- Confirm with the ENTER key or by pressing the STANDARD softkey again.

The selected standard is displayed in the upper right corner of the screen.

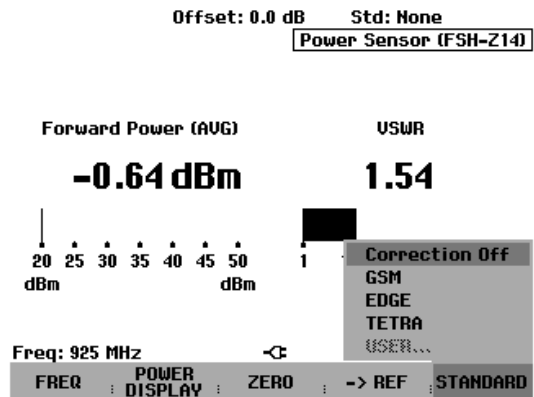

## Taking additional attenuation into account

When the directional power sensor is connected to a test point not directly but via a cable, the influence of cable attenuation can be taken into account. For this purpose, the cable attenuation for the measurement frequency in question is to be entered, i.e. as a positive dB value if the power and matching are to be measured at the source and the cable is connected between the source and the power sensor, and as a negative dB value if the power and matching are to be measured at the load and the cable is connected between the load and the power sensor. The directional power sensor then corrects the power and matching values to produce the results that would have been obtained if it had been directly connected to the test point.

- Press the AMPT key.
- Press the REF OFFSET softkey.

The value entry box for the reference offset opens.

- Enter the desired offset using the rotary knob, the cursor keys or the number keys and confirm the entry with the ENTER key.

The selected offset is displayed in the middle at the top of the screen and is taken into account in the power (level) and matching results.

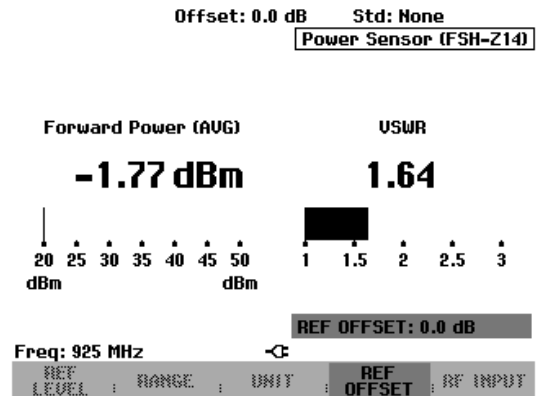

If high powers are applied that exceed the maximum input level of the R&S FSH-Z14 or R&S FSH-Z44, a directional coupler or an attenuator has to be connected ahead of the power sensor. In such cases, the coupling attenuation of the directional coupler or the attenuation value of the attenuator are to be entered as positive dB values (see above) into the R&S FSH3-TV to ensure true measured power readout. In both cases, a termination or an attenuator of sufficient power-handling capacity has to be connected to the power sensor at the load end. The matching readout is irrelevant in such case since it is likewise corrected by taking into account the attenuation value of the termination or attenuator (see measurement via cable).

## Two-port measurements with the tracking generator

The R&S FSH3-TV can be supplied with an optional tracking generator to measure the transfer functions of two-ports or the reflection coefficients of one-ports and two-ports. The tracking generator outputs a signal at the current R&S FSH3-TV frequency. The nominal output level of the tracking generator is -20 dBm / 0 dBm.

Two-port transfer functions can be determined directly by connecting the input of the DUT to the output of the tracking generator and the DUT's output to the R&S FSH3-TV's RF input. A bridge is required to measure the reflection coefficient, e.g. the VSWR Bridge R&S FSH-Z2.

Thanks to the calibration technique used, the R&S FSH3-TV's measurement accuracy is high for both transmission measurements and reflection measurements. The R&S FSH3-TV offers scalar calibration methods as standard; i.e. with transfer function and reflection measurements, the magnitudes are corrected. Vector calibration methods and measurements (option R&S FSH-K2) are possible for increasing the dynamic range and the measurement accuracy. The operation of vector measurements primarily differs in the expanded calibration routines.

- Press the MEAS key.
- Press the MEASURE softkey.

The measurement function submenu opens.

- Using the cursor keys or the rotary knob, select the TRACKING GEN menu item (highlighted in red) and confirm your selection with the ENTER key or the MEAS softkey.

The R&S FSH3-TV turns on the tracking generator and switches to its softkey menu. However, the frequency and level settings from the spectrum analyzer mode are not changed.

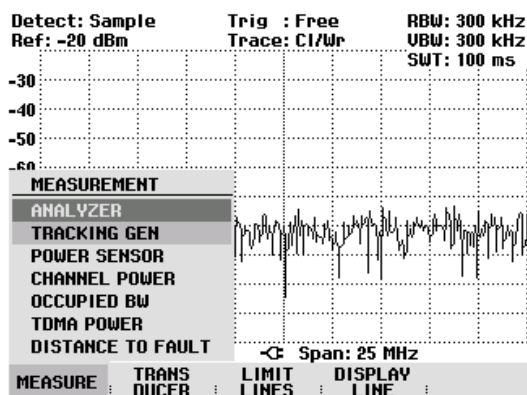

The softkey menu for the tracking generator contains softkeys for calibrating transfer function measurements (TRANSM CAL) and reflection coefficient measurements (REFLECT CAL). Calibration is necessary because the tracking generator output level is not precisely -20 dBm (or 0 dBm, as the case may be) and is also frequency-dependent. If transmission measurements are performed on a two-port, the calibration takes the transmission characteristics of the test setup and the frequency response of the tracking generator into account and corrects the measurement with the correction data that has been obtained. When a reflection measurement is to be performed, during calibration the R&S FSH3-TV measures the reflection coefficient at a short and at an open on the bridge. These two measurements provide the correction data for reflection measurements.

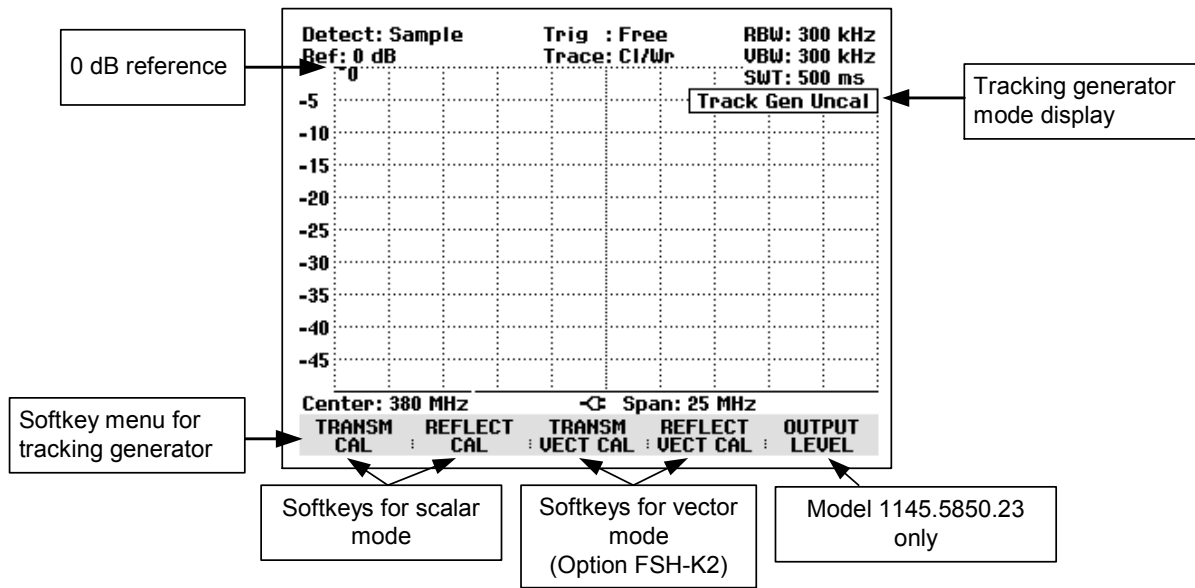

When the tracking generator is switched on, the R&S FSH3-TV displays Track Gen Uncal . This indicates that tracking generator measurements are uncalibrated. The level axis is in the relative unit dB. Apart from the level values, the 0 dB reference is also displayed. This corresponds to a reference level of -20 dBm in the spectrum analyzer mode (= nominal output level of the tracking generator). If an output level of 0 dBm is used with models 1145.5850.23 and 1145.5850.26, the 0 dB reference corresponds to a reference level of 0 dBm.

When the tracking generator is on, measurement parameters like bandwidth or the frequency range are selected with the appropriate keys as in the spectrum analyzer mode. When the MEAS key is pressed, the softkey menu for the tracking generator is displayed.

Before calibration, the output level of the tracking generator (models 1145.5850.23 and 1145.5850.26 only), the frequency range you want and the appropriate reference level should be set because calibration is only valid for the calibrated frequency range and reference. Changing these parameters after calibration invalidates calibration.

When you press the MEAS key twice, the R&S FSH3-TV again opens the menu for selecting the various measurements.

**Setting the output level:**

(models 1145.5850.23 and 1145.5850.26 only)

- Press the OUTPUT LEVEL softkey in the TRACKING GEN menu.

The submenu for selecting the output level opens.

- Using the rotary knob or the cursor keys, place the cursor on the level you want.
- Confirm your selection with the ENTER key or the OUTPUT LEVEL softkey.

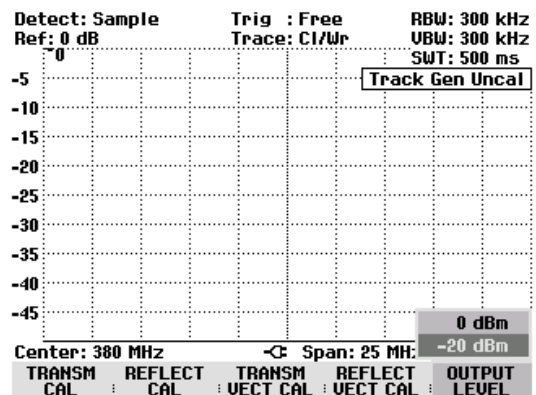



When calibration is over, the R&S FSH3-TV displays **Transmission** in the top right-hand corner of the measurement diagram. This tells the user that the R&S FSH3-TV has been calibrated for transfer function measurements. The softkey label TRANSM CAL is highlighted in green.

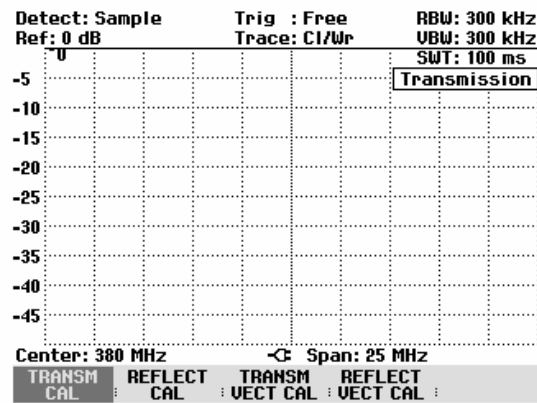

➤ Connect the DUT between the RF input and the generator's output.

The R&S FSH3-TV displays the magnitude of the transfer function. Values can be read off with, for example, the markers.

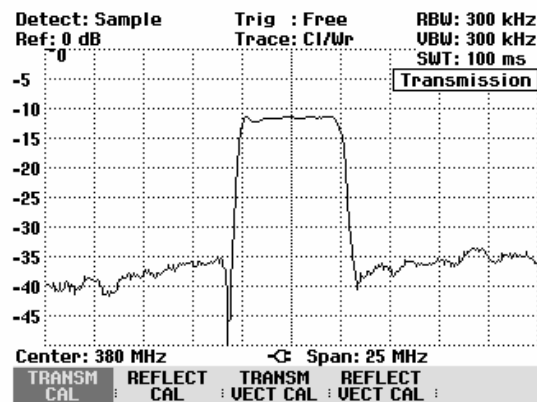

The transmission calibration remains valid until the center frequency or the span is changed on the R&S FSH3-TV. Track Gen Uncal is displayed in the top right-hand corner of the screen when calibration is no longer valid.

If the reference is changed after calibration, greater measurement uncertainty must be anticipated. The R&S FSH3-TV retains the calibration data but displays a red dot before **Transmission** in the top right-hand corner of the screen to indicate a possible increase in measurement uncertainty (< 0.3 dB).

Changing any other of the parameters like bandwidth, detector, sweep time or measurement range has no effect on measurement accuracy. This means they can be changed after calibration without any reduction in accuracy.

When a data set for scalar transmission measurement is stored with calibration performed, the calibration data can be stored along with the other settings (see Chapter 2, section "Saving Calibration Data"). When such a data set is recalled, measurements can be performed without prior calibration, providing the instrument's temperature does not deviate more than 5 °C from its temperature when the data set was stored.

If the temperature deviation is greater, the R&S FSH3-TV outputs a (red) dot in front of **• Transmission**. A precise measurement can then only be made after a calibration.

### Measurement on amplifiers:

With measurements on amplifiers, the reference must be shifted so that the amplifier's transmission function can be seen on the screen. An increase of the reference level corresponds to an increase of the input attenuation. The R&S FSH3-TV provides a reference setting for this purpose. The position of the 0 dB reference can be shifted to positive or negative values.

- Press the AMPT key.
- Press the REF softkey.
- Change the reference using the rotary knob or the cursor keys, or enter a new reference via the numeric keypad.
- Confirm the entry with the ENTER key or the REF softkey.

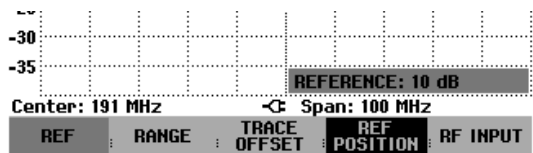

When performing measurements on amplifiers, make sure the R&S FSH3-TV is not overdriven. The risk of overdriving is eliminated when the trace is within the display area on the screen (with REF POSITION = 0 dB and TRACE OFFSET = 0 dB).

The reference can also be shifted without increasing the input attenuation – for example, in order to move the trace to the center of the screen. This is done using the REF POSITION function.

- Press the AMPT key.
- Press the REF POSITION softkey.
- Change the reference position using the rotary knob or the cursor keys, or enter a new reference position via the numeric keypad.
- Confirm the entry with the ENTER key or the REF POSITION softkey.

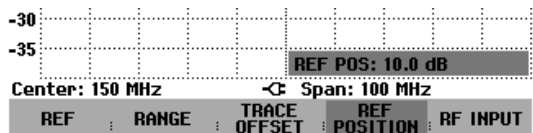

In addition, the trace can be offset without changing the reference and the scale of the y axis.

- Press the AMPT key.
- Press the TRACE OFFSET softkey.
- Change the level offset of the trace using the rotary knob or the cursor keys, or enter a new offset via the numeric keypad.
- Confirm the entry with the ENTER key or the TRACE OFFSET softkey.

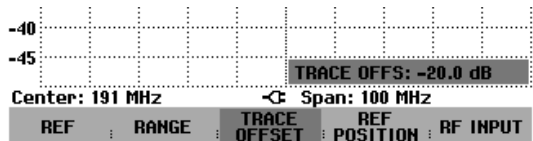

The trace offset function is useful if it is necessary to compensate for a fixed loss or gain during the measurement.



## Vector measurement of transfer function

(only with option R&S FSH-K2)

With vector measurements, the R&S FSH3-TV analyzes both magnitude and phase of the receive signal, thus correcting the influence it has on the measurement result by means of the complex correction values obtained from the calibration routines with correct phase. Reference is made to the calibration standards used (through connection and 50  $\Omega$  termination).

Compared to scalar measurement, the vector measurement of the transfer function yields higher measurement accuracy and dynamic range.

### Switching on vector measurement:

- Press the MEAS key.
- Press the MEAS MODE softkey.
- Select VECTOR from the menu using the cursor keys or the rotary knob.
- Confirm your choice with the ENTER key or the MEAS MODE softkey.

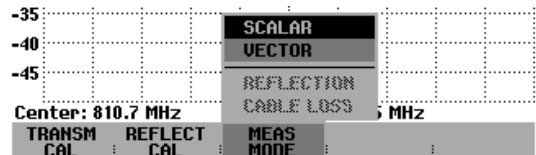

### Calibrating the measurement:

Before the R&S FSH3-TV is calibrated, the desired center frequency and span must be set. If they are set later, the calibration values are lost and the measurement must be recalibrated.

- Press the MEAS key.
- Press the TRANSM CAL softkey.

To calibrate the transfer measurement, the R&S FSH3-TV requests that the RF input be connected to the tracking generator output.

- Connect the RF input of the R&S FSH3-TV directly to the tracking generator output without the DUT.
- Press the F1 or F2 (CONTINUE) softkey to start calibration.
- By pressing the F4 or F5 (CANCEL) softkey, calibration can be aborted.

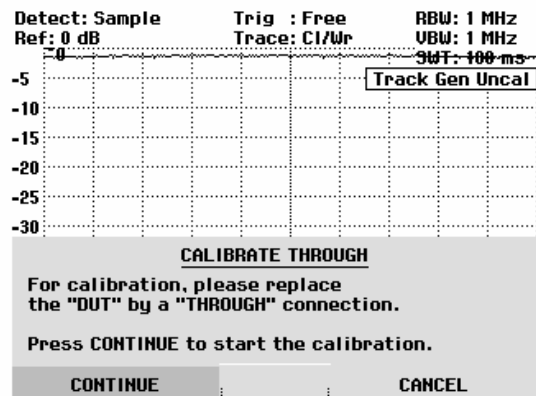

During calibration, the R&S FSH3-TV outputs the message "Calibrating THROUGH, please wait...".

Calibration can be aborted with CANCEL.

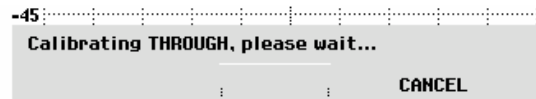

The R&S FSH3-TV then requests to terminate the output of the tracking generators into 50 Ω.

- Connect the generator output with the 50 Ω termination.
- Press the F1 or F2 (CONTINUE) softkey.

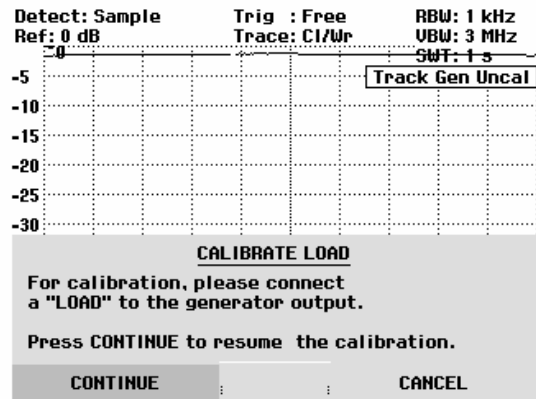

During calibration, the R&S FSH3-TV outputs the message "Calibrating LOAD, please wait".

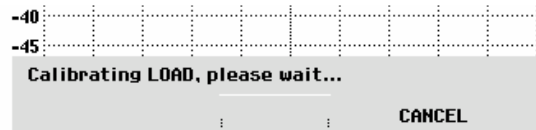

When calibration is over, **Transm (vect)** is displayed in the top right-hand corner to indicate that the R&S FSH3-TV is vector-calibrated for transfer measurement.

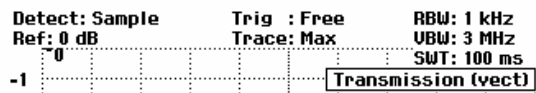

Connect the DUT between the tracking generator output and the RF input. The R&S FSH3-TV displays the magnitude of the transfer function of the DUT.

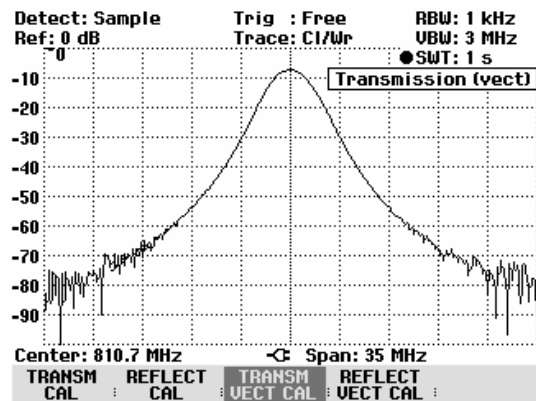



- Connect a short to the measurement input of the bridge.
- Using CONTINUE start the SHORT calibration.
- Calibration can be aborted with CANCEL.

*Note: Instead of a SHORT, the R&S FSH3-TV can be calibrated again with an OPEN. As the R&S FSH3-TV only measures the magnitude of the reflected voltage, it cannot distinguish between a SHORT and an OPEN. However, calibration with a SHORT increases measurement accuracy because the R&S FSH3-TV takes the average of the calibration values for the SHORT and the OPEN.*

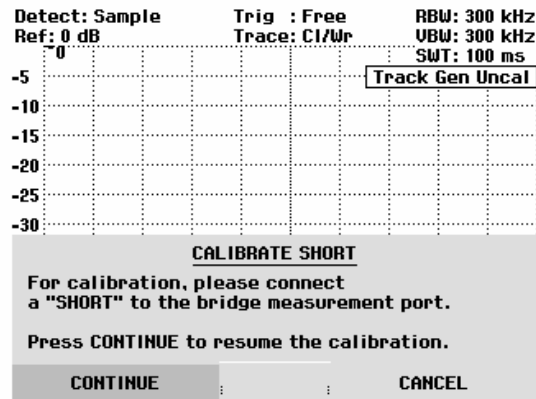

During calibration, the R&S FSH3-TV outputs the message "Calibrating SHORT, please wait...". Calibration can be aborted with the CANCEL softkey.

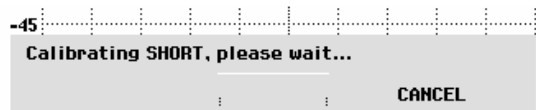

When calibration is over, the R&S FSH3-TV outputs the message "Reflect. calibrated" for 3 seconds.

**Reflection** is displayed in the top right-hand corner of the measurement diagram to indicate that the R&S FSH3-TV is calibrated for reflection measurements. The softkey label REFLECT CAL is highlighted in green.

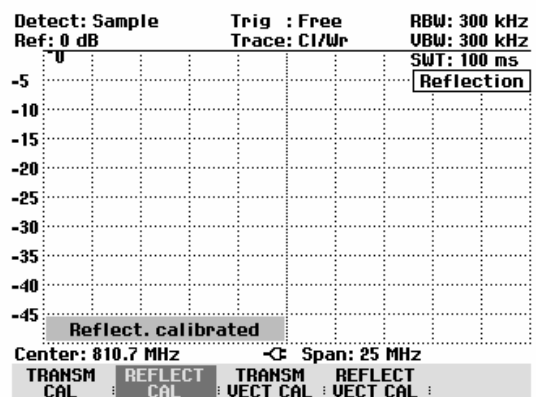

- Connect the DUT to the measurement port of the VSWR bridge.

The R&S FSH3-TV displays the return loss of the DUT.

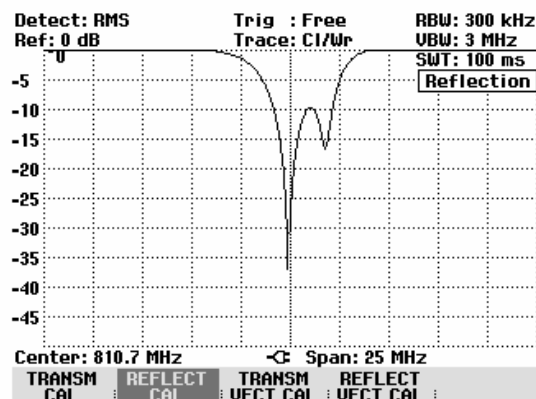

To display the (VSWR), the measurement range must be switched over.

- Press the AMPT key.
- Press the RANGE softkey.

The submenu for selecting the display ranges opens. There are two ranges for displaying VSWR. For DUTs with good matching, the VSWR display range 1 to 2 is best. If matching is less good, there is a larger range with VSWR = 1 to 6.

Select the range you want with the cursor keys or the rotary knob.

Confirm your selection with the ENTER key or by pressing the RANGE softkey.

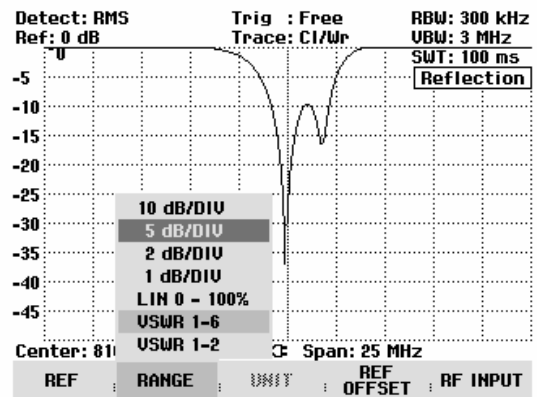

The R&S FSH3-TV displays the VSWR of the DUT.

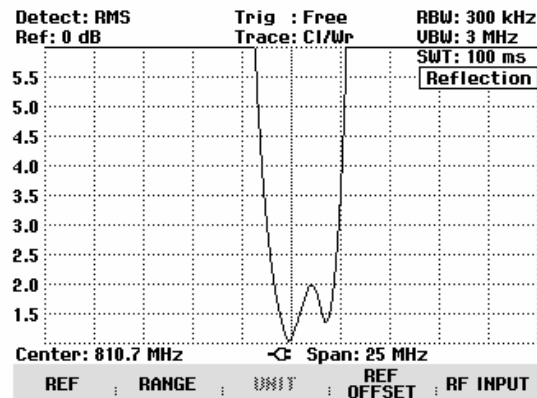

Reflection calibration remains valid until the R&S FSH3-TV's center frequency or span is changed. If calibration becomes invalid, the R&S FSH3-TV displays **Track Gen Uncal** in the top right-hand corner of the screen.

If the reference is changed after calibration, a larger measurement uncertainty must be anticipated. The R&S FSH3-TV retains the calibration data but places a red dot before the Reflection display in the top right-hand corner of the screen (**• Reflection**) to indicate a possible increase in measurement uncertainty up to 0.3 dB.

Changing other parameters like bandwidth, detector, sweep time or measurement range has no effect on measurement accuracy. This means they can be changed after calibration without any reduction in accuracy.

When a data set for scalar reflection measurement is stored with calibration performed, the calibration data can be stored along with the other settings (see Chapter 2, section "Saving Calibration Data"). When such a data set is recalled, measurements can be performed without prior calibration, providing the instrument's temperature does not deviate more than 5 °C from its temperature when the data set was stored.

If the temperature deviation is greater, the R&S FSH3-TV outputs a (red) dot in front of **• Reflection**. A precise measurement can then only be made after a calibration.

### Vector measurement of reflection

(only available with option R&S FSH-K2)

Unlike with scalar measurement, the R&S FSH3-TV corrects the waveform reflected by the DUT according to magnitude and phase by means of the correction values obtained from calibration. In addition to calibration with open circuit and short circuit, calibration with a 50 Ω termination is necessary. Thus, the characteristics of the VSWR bridge (directivity and impedances) no longer affect the measurement result. Rather, the decisive factor is the quality of the calibration parameters open circuit, short circuit and 50 Ω termination.

Vector measurement therefore yields higher dynamic range and thus accuracy.

With vector measurements, the R&S FSH3-TV sets the bandwidths (Res BW and Video BW) to a fixed, unchangeable value. It invariably uses the sample detector as a detector. All other measurement parameters can be set as with scalar measurement.

#### Switching on vector measurement:

- Press the MEAS key.
- Press the MEAS MODE softkey.
- Select VECTOR from the menu using the cursor keys or the rotary knob.
- Confirm your choice with the ENTER key or the MEAS MODE softkey.

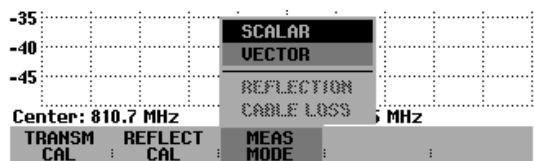

#### Calibration:

Before the R&S FSH3-TV is calibrated, the desired center frequency and span must be set. If they are set later, the calibration values are lost and the calibration must be repeated.

- Press the REFLECT CAL softkey.

The R&S FSH3-TV displays a message requesting termination of the measurement input into an open circuit (Open).

- Terminate the measurement input of the VSWR bridge or the end of the measurement cable into an open circuit.
- Start open-circuit calibration by pressing the first or the second softkey (CONTINUE). During calibration, the R&S FSH3-TV outputs the message "Calibrating OPEN, please wait...".
- Calibration can be aborted at any stage with the CANCEL softkey.

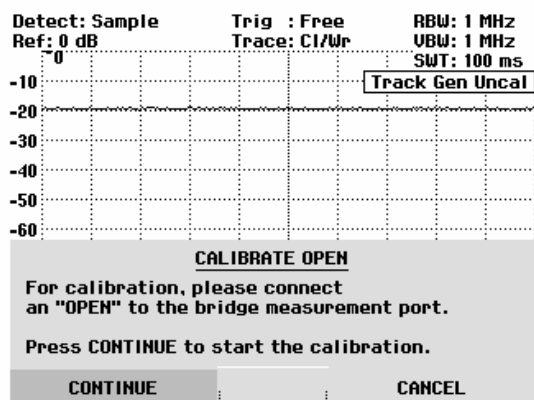

When the open-circuit calibration is over, the R&S FSH3-TV outputs a message requesting the termination of the measurement port into a short circuit.

- Terminate the measurement input of the bridge or the end of the measurement cable into a short circuit.
- Start the short-circuit calibration by pressing the first or the second softkey (CONTINUE). During calibration, the R&S FSH3-TV outputs the message "Calibrating SHORT, please wait...".

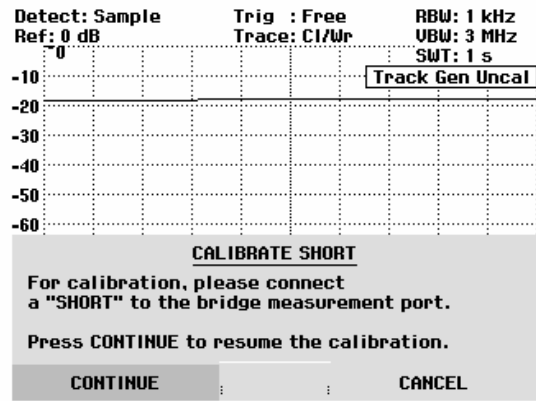

In the third step of calibration, terminate the measurement port into a 50 Ω termination.

- Terminate the measurement input of the bridge or the end of the measurement cable into a 50 Ω termination.
- Start termination calibration by pressing the first or the second softkey (CONTINUE). During calibration, the R&S FSH3-TV outputs the message "Calibrating LOAD, please wait...".

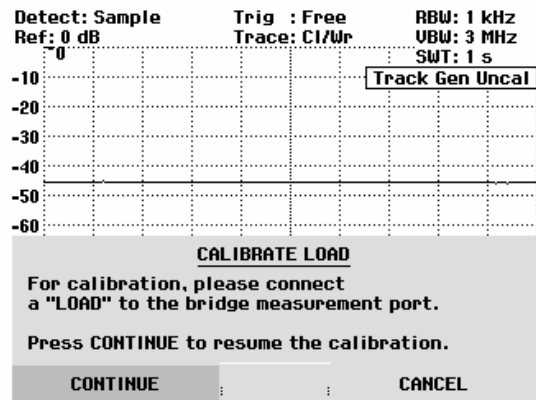

When calibration is over, the R&S FSH3-TV outputs the message "Reflect. calibrated" for three seconds.

Refl (vect) is displayed in the top right-hand corner of the diagram to indicate that the R&S FSH3-TV is vector-calibrated for reflection measurements. The softkey label REFLECT CAL is highlighted in green.

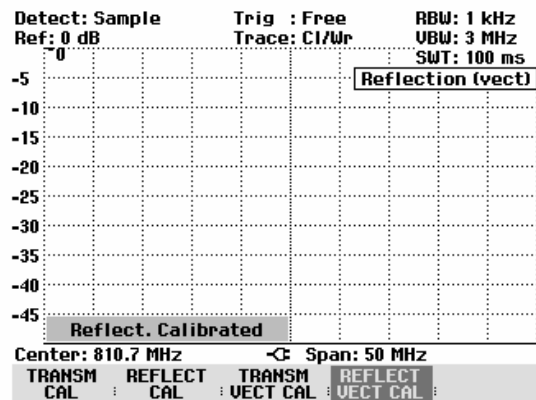

The reflection calibration remains valid until the center frequency or the span is changed on the R&S FSH3-TV. Track Gen Uncal is displayed in the top right-hand corner of the screen when calibration is no longer valid.

If the reference level is changed (AMPT key, REF softkey) after calibration, greater measurement uncertainty must be anticipated. The R&S FSH3-TV retains the calibration data but displays a red dot before the Refl (vect) display in the top right-hand corner of the screen to indicate a possible increase in measurement uncertainty.

A change in sweep time does not affect reflection measurement.

The R&S FSH3-TV internally monitors the temperature. If temperature changes cause an increase in measurement error, the R&S FSH3-TV shows a red dot to the left of the measurement mode display (• Refl (vect)).

### Display of reflection in vector measurement

Since the R&S FSH3-TV also evaluates the magnitude and phase during measurements following vector calibration, additional display capabilities are available as compared to scalar measurement. Owing to the larger dynamic range, the display ranges for the standing wave ratio (VSWR) and VSWR 1 –1.5 and VSWR 1 –1.1 are expanded. Thus, well matched DUTs can be measured with greater precision and higher display resolution.

However, one of the main advantages of vector measurement is also being able to display the complex measurement results in a Smith chart. This provides a much more in-depth look at the characteristics of the DUT than by displaying the reflection magnitude as return loss or VSWR.

- Press the AMPT key.
- Press the RANGE softkey.
- Using the cursor keys or rotary knob, select SMITH CHART from the menu.

Confirm your selection with the ENTER key or by pressing the RANGE softkey again.

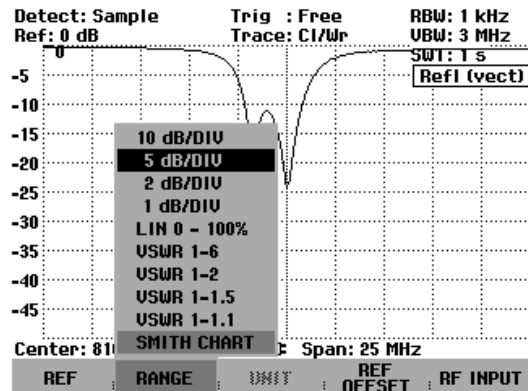

The R&S FSH3-TV displays the reflection of the DUT in the Smith chart.

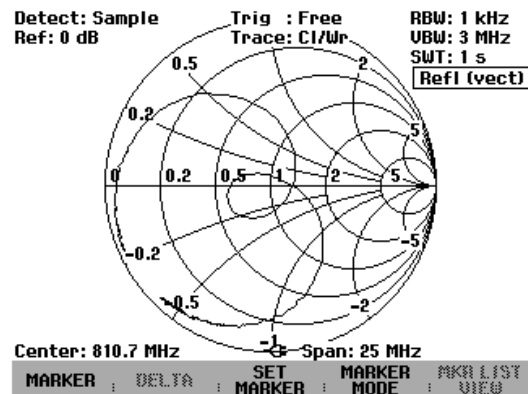



### The markers in a Smith chart

As in scalar measurements, all marker functions (marker, delta marker, multi-markers) are available in the Smith chart.

- Press the MARKER key.

The R&S FSH3-TV activates the marker menu and a marker.

Using the rotary knob, cursor keys or numeric entry, move the marker on the complex impedance trace.

The numeric output of the marker values is provided along with the marker frequency and the complex impedance ((real component) + j (imaginary component)) in ohms.

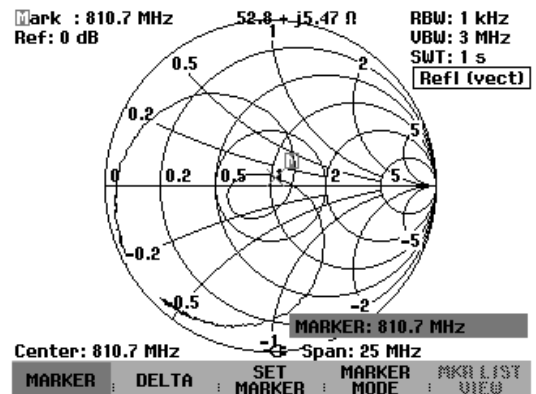

The output values for the delta marker(s) are in relation to the value of the reference marker.

### Limit lines in the Smith chart:

To allow visual monitoring of VSWR limits, the R&S FSH3-TV offers VSWR limit values in the Smith chart. In a Smith chart, a VSWR limit value is shown by a circle whose center point is the reference resistance and whose radius is determined by the VSWR value. All values within the circle have a VSWR value that is smaller than the VSWR value defined by the circle.

To activate the VSWR limit value:

- If starting from the main menu for the tracking generator, press the MEAS key. If starting from any other menu, press the MEAS key twice.
- Press the LIMIT LINES softkey.

The R&S FSH3-TV displays the menu for limit values in a Smith chart representation. If a VSWR limit value is already activated, the VSWR LIMIT softkey label is highlighted in green.

- To enter a VSWR limit value or to activate the available limit value, press the VSWR LIMIT key.
- Change the displayed VSWR limit value to the desired value by using the rotary knob, or enter a new limit value by using the numeric keys.
- Press the ENTER key to complete the entry.

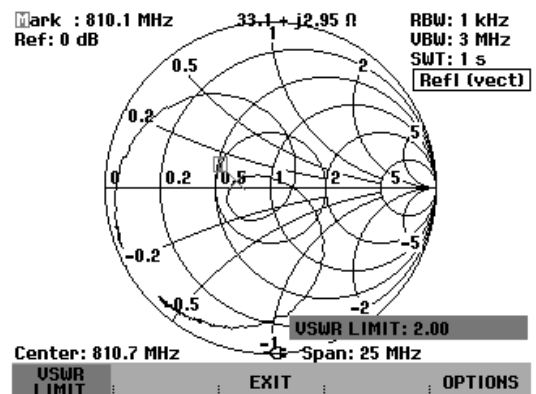

To deactivate the VSWR limit value:

- If starting from the main menu for the tracking generator, press the MEAS key. If starting from any other menu, press the MEAS key twice.
- Press the LIMIT LINES softkey.

The VSWR LIMIT softkey label is highlighted in green.

- Press the LIMIT LINES softkey twice.

The VSWR limit value is now deactivated.

As with limit value lines in scalar diagrams, the R&S FSH3-TV also offers automatic monitoring of limit values in Smith charts. If the entire impedance trace falls within the VSWR circle, the R&S FSH3-TV returns PASS after each sweep. If part of the trace falls outside the circle, FAIL is returned.

Limit value monitoring can be configured by using the OPTIONS softkey from the LIMIT LINES menu (see section "Using Limit Lines").

## One-Port Measurement of Cable Loss

(Available only if the option R&S FSH-K2 is installed.)

When measuring return loss at the end of short-circuited or open-circuit cables, cable loss can be calculated on the basis of the following aspect: A short circuit or an open circuit at the end of the cable completely reflects the traversing wave. Since the wave traverses the cable twice, the returning wave at the measurement port of the bridge is attenuated by twice the amount of the cable loss. The level ratio of the received signal to the one fed to the cable is thus the same as twice the loss of the measured cable.

If the option R&S FSH-K2 is installed, the R&S FSH3-TV enables users to measure cable loss directly in accordance with the methods for return loss measurement without having to convert return loss to cable loss.

### Operation:

- Connect the R&S FSH-Z2 bridge to the R&S FSH3-TV.
- Activate the TRACKING GEN mode on the R&S FSH3-TV (MEAS key, MEASURE: TRACKING GEN softkey).
- Set the required frequency range on the R&S FSH3-TV.
- Switch on vector measurement (MEAS key, MEAS MODE softkey, VECTOR menu item).
- Calibrate the R&S FSH3-TV (MEAS key, RELECT CAL softkey).
- Connect the cable to be measured to the measurement port of the bridge. The other end of the cable must be terminated with a short circuit or left open.

The R&S FSH3-TV shows the return loss of the cable.

- Press the MEAS MODE softkey.
- Using the rotary knob or the cursor keys, select CABLE LOSS from the menu.
- Confirm the selection with the ENTER key or the MEAS MODE softkey.

The R&S FSH3-TV will now display the measured cable loss in dB.

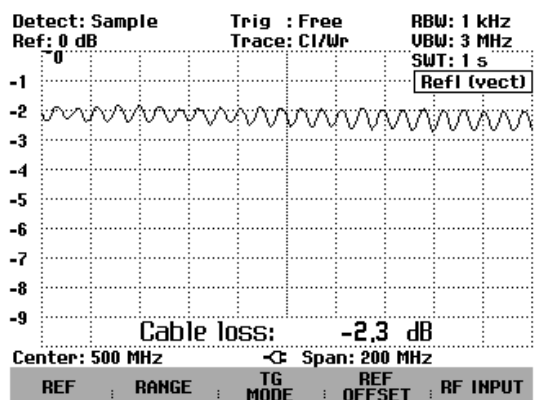

The R&S FSH3-TV calculates the cable loss from the average of the maximum and minimum values of the displayed trace. Thus, the cable loss is an average value within the displayed frequency range. Loss at specific frequencies can be determined with one or more markers.

# Cable Measurements

(Only available with option Distance-To-Fault Measurement, R&S FSH-B1)

Measurements to determine the characteristics of cables to the antenna are key tasks when transmission equipment is being installed or maintained. Cable damage or bad connections have an adverse effect on the efficiency of the transmitter system. In conjunction with a tracking generator and the option "Distance-To-Fault Measurement" (DTF, R&S FSH-B1), the R&S FSH3-TV can locate cable faults and determine their distance from the measurement plane.

The only inputs required are the cable type and the approximate length. Using these parameters, the R&S FSH3-TV measures the distance to any faults and the degree of mismatch. It is easy to define the cable characteristics with the supplied "FSH View" software package and to transfer them to the R&S FSH3-TV. Up to 10 cable types can be stored by the R&S FSH3-TV.

The R&S FSH3-TV measures the sum of the tracking generator signal and the signal reflected by the cable under test in the frequency domain. Depending on the phase of the signal reflected at a fault relative to the generator signal there is either reinforcement or cancellation. Because of this effect there is ripple on the received sum signal in the frequency domain. The R&S FSH3-TV fast Fourier transforms the received signal to the time domain. Using the characteristic data of the cable under test, the R&S FSH3-TV directly calculates how far the reflections have travelled from the fault. The magnitude of the fault is given by the height of the reflection at a certain distance.

### Test setup:

- Connect the cable of the VSWR Bridge R&S FSH-Z2 to the power sensor input on the R&S FSH3-TV.
- Connect the bridge to the generator output and the RF input on the R&S FSH3-TV.
- Connect the cable supplied with option R&S FSH-B1 to the bridge input.

*Note: For distance-to-fault measurements, a cable of one meter length must be connected to the output of the R&S FSH-Z2. Results are useless without this cable.*

### Calling the function:

- Press the MEAS key.
- Press the MEASURE softkey.

The measurement function submenu opens.

Using the cursor keys or the rotary knob, select the DISTANCE TO FAULT menu item and confirm your selection with the ENTER key or the MEAS softkey. The R&S FSH3-TV turns on the "Distance To Fault" measurement function.

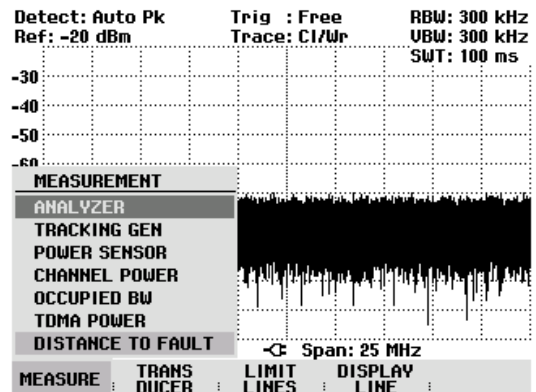

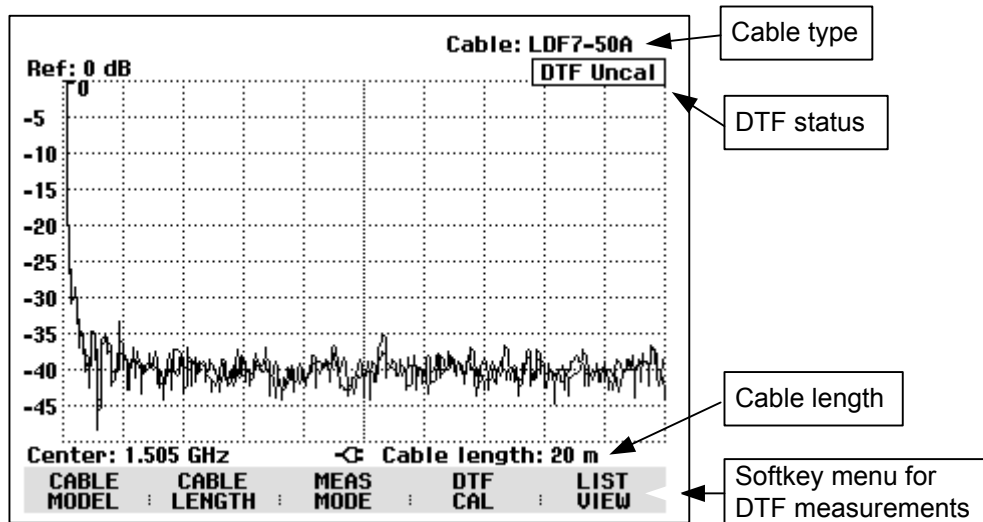

To perform distance-to-fault measurements, the R&S FSH3-TV needs to “know” the type of cable and its approximate length.

The cable type must be known to determine the speed of propagation and so the distance to any fault along the cable. The attenuation of the cable must be known to determine the size of the fault correctly. The R&S FSH3-TV automatically sets the span according to the approximate length of the cable.

## Cable selection

Frequency-dependent cable models can be generated with the supplied R&S FSH View Windows software package and loaded into the R&S FSH3-TV. The procedure is described in the R&S FSH View manual. The R&S FSH3-TV can store up to 100 different cable types in its internal memory. (The total number of storable limit lines, transducer factors and cable models is 100. If transducer factors or limit lines are stored simultaneously, the maximum number of cable models decreases correspondingly.)

Frequency-dependent cable models can also be defined directly on the R&S FSH3-TV in the corresponding menu. In this way, cable models not generated with R&S FSH View can be added.

If the distance to a cable fault is to be located precisely, it is essential to use the appropriate cable model. If not, the R&S FSH3-TV will not be able to correctly determine the distance of the fault from the measurement plane and the magnitude of the reflection at the fault.

**Selecting a cable model from a predefined list:**

- Press the CABLE MODEL softkey.

The R&S FSH3-TV displays the list of cable models.

- Using the rotary knob or the cursor keys, select the appropriate cable model.
- Using the softkey, activate the cable model you have selected.

The R&S FSH3-TV returns to the DTF measurement function and displays the cable used for the measurement in the top right-hand corner of the screen.

11/12/2002	CABLE LIST	18:51:35
RG214	11/12/2002 17:46:52	
RG223U	11/12/2002 16:12:39	
RG213U	11/12/2002 16:11:54	
S-FLC12-50J	07/12/2002 12:47:47	
RG8U	07/12/2002 10:22:28	
LMR600	06/12/2002 23:57:17	
LMR900	06/12/2002 23:55:28	
LMR1200	06/12/2002 23:53:13	
RG142	23/11/2002 14:31:54	
RG58C	08/04/2002 08:44:42	
RG141A	08/04/2002 08:44:42	
RTK161SG	21/02/2002 10:00:54	

SELECT : : EXIT : LIST-> PRINTER

**Definition of cable parameters on the R&S FSH3-TV:**

- Press the CABLE MODEL softkey.
- Press the SELECT USER MOD softkey.

The softkey is highlighted in green to indicate that a user-defined cable model has been selected. The cable model can be checked or modified using the DEFINE USER MOD softkey.

- Press the DEFINE USER MOD softkey.

A menu for entering the frequency, the velocity factor and the attenuation opens.

19/07/2003	CABLE LIST	14:39:17
RG8U	18/12/2002 18:27:24	
RG58C	18/12/2002 18:27:24	
RG223U	18/12/2002 18:27:24	
RG214	18/12/2002 18:27:24	
RG213U	18/12/2002 18:27:24	
RG142	18/12/2002 18:27:24	
RG141A	18/12/2002 18:27:24	
LMR900	18/12/2002 18:27:24	
LMR600	18/12/2002 18:27:24	
LMR1200	18/12/2002 18:27:24	

FREQUENCY...  
VELOCITY FACTOR...  
ATTENUATION...

SELECT : SELECT USER MOD : EXIT : DEFINE USER MOD : LIST-> PRINTER

- Select FREQUENCY... and confirm with the ENTER key.

The current frequency is displayed in the value entry box.

- Confirm the frequency with the ENTER key or enter a new frequency.

FREQUENCY: 1.5 GHz

SELECT : SELECT USER MOD : EXIT : DEFINE USER MOD : LIST-> PRINTER

- Press the DEFINE USER MOD softkey.
- Select VELOCITY FACTOR... and confirm with the ENTER key.

The current velocity factor is displayed in the value entry box.

- Confirm the current velocity factor with the ENTER key or enter a new velocity factor and confirm with the ENTER key or the DEFINE USER MOD softkey.

VELOCITY FACT: 0.880

SELECT : SELECT USER MOD : EXIT : DEFINE USER MOD : LIST-> PRINTER

The velocity factor can be found, for example, in the manufacturer's data sheet for the cable in question.

- Press the DEFINE USER MOD softkey.
- Select ATTENUATION... and confirm with the ENTER key.

The current cable attenuation is displayed in the value entry box in dB/m or dB/ft, depending on the unit of length selected in the setup menu.

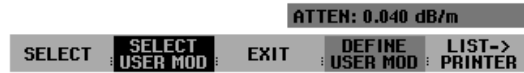

- Confirm the current cable attenuation with the ENTER key or enter a new cable attenuation and confirm with the ENTER key or the DEFINE USER MOD softkey.

The cable attenuation can be found, for example, in the manufacturer's data sheet for the cable in question.

**Preselecting the cable length:**

The R&S FSH3-TV uses the cable length to determine the optimal span for the measurement. The longer the cable under test is, the smaller the span used by the R&S FSH3-TV. The R&S FSH3-TV also calculates the cable attenuation from the selected cable model and the length setting so that the magnitude of the reflection at the fault is measured correctly. If the graphics display mode is selected for the results, the R&S FSH3-TV scales the x axis so that it represents the total length of the cable.

If the entered cable length is less than the actual cable length, the R&S FSH3-TV does not display the faults of the complete cable. A reflection at the end of the cable will not be shown. However, deliberately entering a cable length that is too short is a good way of increasing distance-to-fault accuracy for a fault that is near to the measurement plane. If the entered cable length is greater than the actual length, the measured values for lengths beyond the cable length are useless because they are caused by multiple reflections. If the length of the cable is not known precisely, it is best to enter a length that is about 20 % to 50 % greater than the best estimate of the cable length.

- Press the CABLE LENGTH softkey.

The R&S FSH3-TV opens the cable length (CABLE LEN) value entry box and displays the current length setting in meters or feet. The unit of length is selected by, and depends on, SETUP: LOCAL SETTINGS: UNIT OF LENGTH.

- Using the numeric keys, enter the cable length in meters and terminate the entry with the ENTER key or one of the unit keys, or
- Using the rotary knob (1 m steps) or the cursor keys (10 m steps) adjust the cable length.

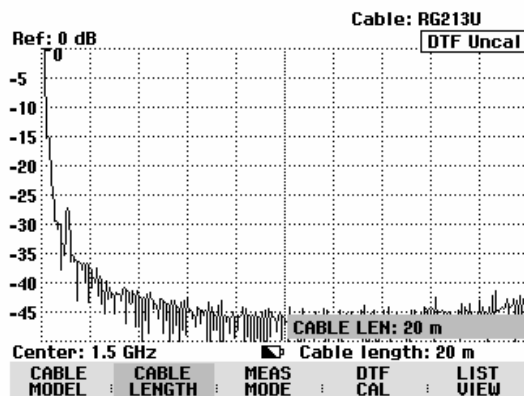

The minimum cable length is 3 meters or 10 feet. This value is determined by the maximum frequency range of the R&S FSH3-TV. A cable length of max. 1000 m can be entered. The maximum cable length that is suitable for measurements depends on the cable attenuation. Since the test signal must be twice routed through the cable, the signal reflected at the cable end arrives with twice the cable attenuation in attenuated form at the input of the power divider. Dynamic range decreases with increasing cable length.

If the cable attenuation exceeds 10 dB, the R&S FSH3-TV outputs a warning indicating that the cable attenuation is too high. It also indicates the maximum recommended cable length for obtaining accurate results.

Pressing CONTINUE accepts the entry.

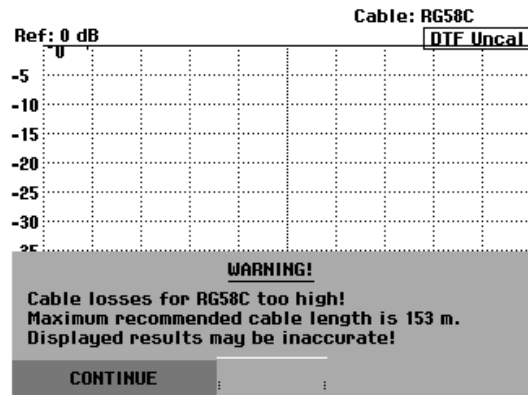

## Selecting the frequency range

In the default setting, the R&S FSH3-TV automatically selects the frequency range around the set center frequency on the basis of the cable length and cable model. The R&S FSH3-TV selects a frequency range that enables maximum length resolution.

Particularly with relatively short cables, the frequency range in which the cable is specified may then be exceeded. Therefore, the R&S FSH3-TV allows the user to define the frequency range in which the distance-to-fault measurement is carried out. However, the length resolution of the measurement is reduced by using smaller frequency ranges.

When setting the frequency range, users are advised first to set the span and then the center frequency. This prevents a message from being output stating that the desired center frequency cannot be set for the span currently being used for the distance-to-fault measurement.

- Press the SPAN key.

The R&S FSH3-TV displays the span menu for the DTF measurement. If automatic setting of the span is selected, the AUTO SPAN softkey label is highlighted in green. If the AUTO SPAN softkey is pressed, the R&S FSH3-TV sets the span for the best length resolution. If the required span is too large for the current center frequency, the R&S FSH3-TV sets the center frequency to the smallest possible frequency.

- Press the MANUAL SPAN key.
- Set the required span by using either numeric entry, the cursor keys or the rotary knob.
- Confirm the setting with the ENTER key or by again pressing the MANUAL SPAN softkey again.

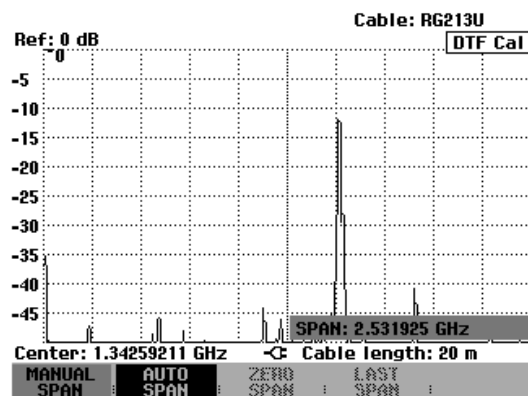

The minimum span that can be set is either 1/10 of the span automatically set by the R&S FSH3-TV in the case of AUTO SPAN or 200 MHz (whichever is smaller). Spans larger than the ones set by the R&S FSH3-TV with AUTO SPAN are not allowed. If an attempt is made to set smaller or larger spans, the R&S FSH3-TV responds with "Minimum reached" or "Range exceeded".



- Press the FREQ key.
- Using either the numeric keys, the cursor keys or the rotary knob, set the desired frequency.
- Confirm the entry with the ENTER key or the CENTER FREQ softkey.

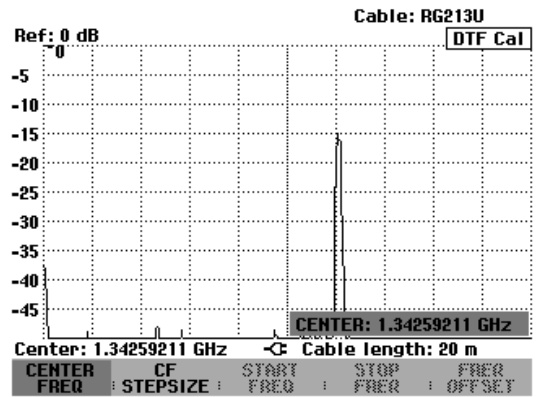

### Calibrating the test setup

The test setup must be calibrated before any measurements are performed. To perform calibration, a SHORT is required at the output of the 1 m measurement cable. An OPEN can be used instead of a SHORT. However, if an OPEN is used, greater measurement uncertainties must be expected as an OPEN is not defined as precisely as a SHORT.

*Note: The reference plane must be the output of the 1 m measurement cable; i.e. the measurement cable may not be dispensed with. If the output of the VSWR bridge is used as the reference plane, the DTF results are useless.*

- Press the DTF CAL softkey.

The R&S FSH3-TV opens a text window which prompts the user to terminate the measurement cable with a SHORT.

- Firmly screw the SHORT to the output end of the measurement cable.
- Press the CONTINUE softkey to start the SHORT calibration.
- Calibration can be aborted by pressing CANCEL.

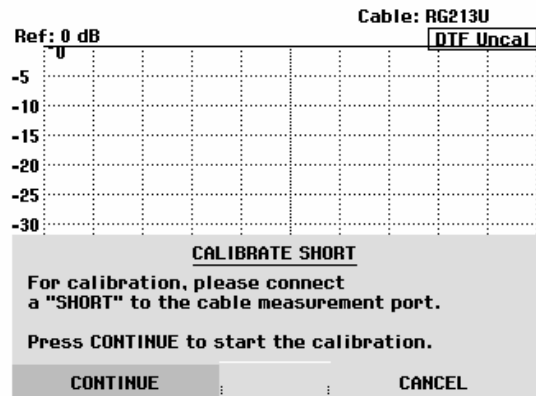

While SHORT calibration is in progress, the R&S FSH3-TV outputs the message "Calibrating SHORT, please wait..."

Calibration can be aborted with the CANCEL softkey.

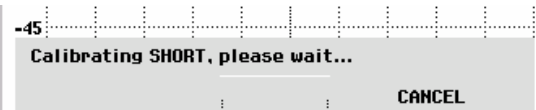

When calibration is over, the R&S FSH3-TV displays DTF CAL in the top right-hand corner of the screen. The REFLECT CAL softkey label is highlighted in green to indicate that calibration has been successfully completed.

The trace displays cable reflections versus distance from the measurement plane.

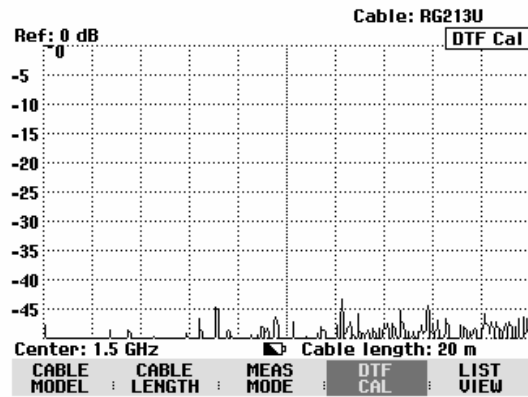

**Note to Calibration:**

Calibration is performed over the entire R&S FSH3-TV frequency range. This eliminates the need for recalibration when a different cable length is selected. The calibration data are saved in the R&S FSH3-TV's internal memory so that calibration remains effective when switchover is made to another operating mode or the instrument is switched off. As a precondition for calibration to remain valid, however, the instrument temperature must not change by more than 5 °C after calibration. If the temperature changes by more than 5 °C, a red circle is placed ahead of DTF CAL to indicate that there is a risk of increased measurement error. In such a case, it is advisable to recalibrate the test setup.

- Unscrew the SHORT from the measurement cable.
- Screw the cable under test to the measurement cable.

The R&S FSH3-TV displays the reflections produced in the cable under test. The measurement diagram on the right shows a cable that is approximately 15 m long and fitted with a connector 5 m from the start. The end of the cable is terminated with a 3 dB attenuator pad.

The R&S FSH3-TV shows that the return loss of the reflection from the termination at the end of the cable (approx. 157 m) is approx. 7 dB. The connector, for example, is the 20 dB peak at 5 m. On the extreme left of the trace, the matching of the connection to the cable under test can be seen.

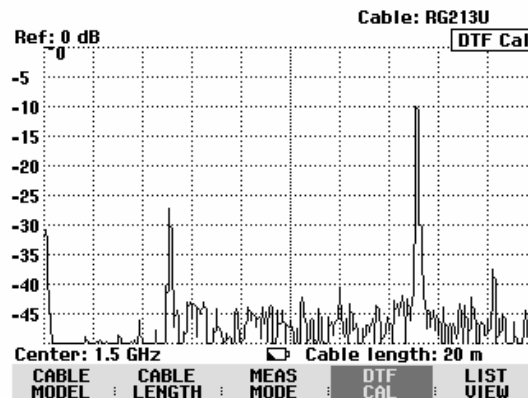

Alternatively to the return loss, the R&S FSH3-TV can also show the VSWR of the faults. Pressing the AMPT key switches to the VSWR display.

- Press the AMPT key.
- Press the RANGE softkey.
- From the list of possible range settings, select VSWR 1-6, VSWR 1-2, VSWR 1-1.5 or VSWR 1-1.1. (The ranges VSWR 1-1.5 and VSWR 1-1.1 are available only if the R&S FSH-K2 option is installed.)
- Confirm your choice with the ENTER key or the RANGE softkey.

The R&S FSH3-TV now shows the VSWR of the measured cable over the cable length.

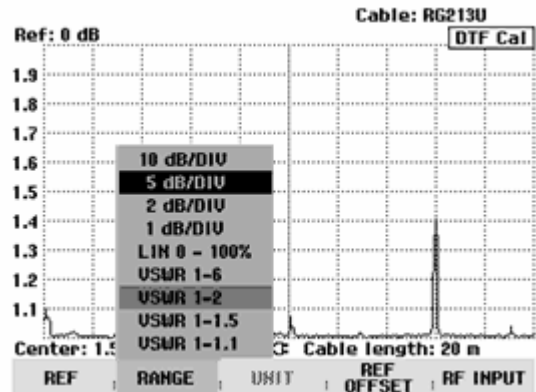

The R&S FSH3-TV can also list any cable faults. It displays the return loss and distance from the measurement plane of all reflections that exceed a settable threshold.

- Press the LIST VIEW softkey in the Distance to Fault menu.

The R&S FSH3-TV opens the threshold value entry box and also displays the threshold as a horizontal line across the measurement diagram.

- Set the threshold using the cursor keys (5 dB steps), the rotary knob (1 dB steps) or the number keys.

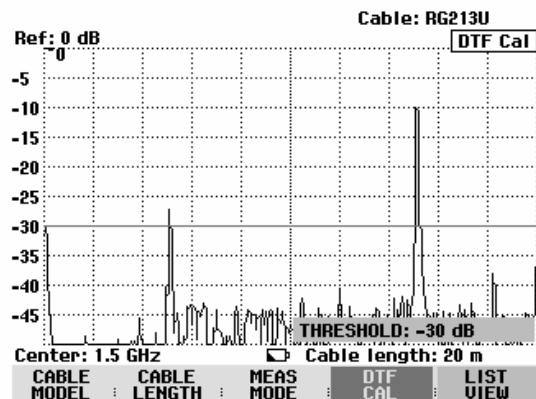

- Press the ENTER key or the LIST VIEW softkey again.

The R&S FSH3-TV displays a table listing all the reflections that are above the threshold sorted according to distance from the measurement plane.

Threshold: -30 dB			Cable: RG213U	
			Mode : DTF cal	
PEAK	DISTANCE	VALUE		
1	5.07 m	-27.3 dB		
2	15.07 m	-10.0 dB		

- To change the threshold for the table display, press the THRESHOLD softkey and enter the new value.
- Use LIST->PRINTER to output the list to a printer.
- To close the list and to return to the graphics display mode, press the EXIT softkey.



## Locating cable faults by means of the marker function

The distance to cable faults or the distance between any two faults can also be read off with the marker.

- Press the MARKER key.

The R&S FSH3-TV opens the marker menu and places the marker on the fault with the largest reflection. The marker readout gives the distance of the fault from the measurement plane in meters and its return loss.

The marker that indicates the distance from the measurement plane is renamed the DISTANCE MARKER. It is activated for entry (DISTANCE value entry box).

- Change the distance marker by entering a number, adjusting the rotary knob (pixel by pixel) or by using the cursor keys (step = 10 % of the span).

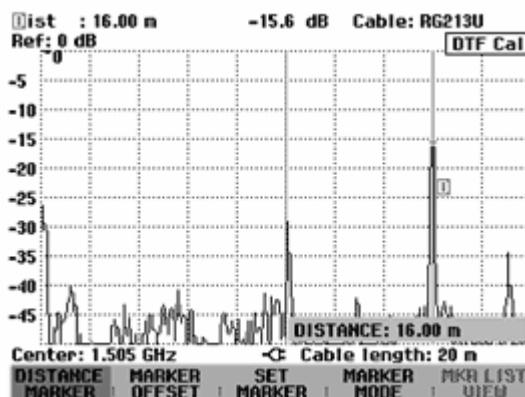

The reference plane to which the distance of a reflection is referred can be redefined using the marker offset.

- To define a new reference plane for the marker, press the MARKER OFFSET softkey.

The R&S FSH3-TV turns on the distance marker (OFFSET) and places it on the start of the trace. The offset marker readout box displays the distance from the measurement plane in meters and the return loss. The main marker (Dist) now gives the distance from the marker offset.

The marker readout label indicating the distance from the main marker is renamed the Offset. It is activated for an entry (OFFSET entry box).

- Change the offset marker by entering a number, adjusting the rotary knob (pixel by pixel) or by using the cursor keys (step = 10 % of the span).

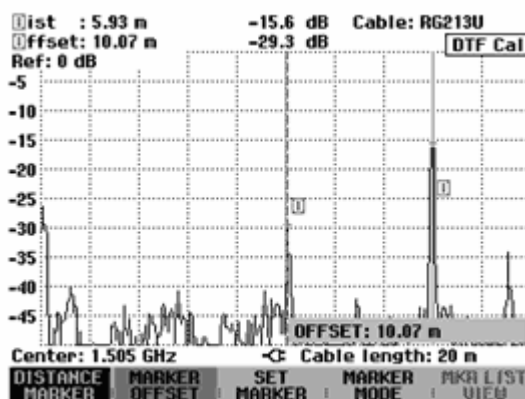

As is the case with spectrum analysis, the R&S FSH3-TV provides functions to automatically position the marker or the marker offset on the trace. These can all be accessed by pressing the SET MARKER softkey.

- Press the SET MARKER softkey.

The R&S FSH3-TV opens the submenu for automatically setting the active marker.

- Using the rotary knob or the cursor keys, select the menu item you want.
- Confirm your selection with the ENTER key or by pressing the SET MARKER softkey again.

The R&S FSH3-TV has the following functions:

- PEAK places the active marker on the highest reflection shown by the trace.
- NEXT PEAK places the active marker on the next highest reflection on the trace relative to the current position.
- MINIMUM places the active marker on the lowest reflection shown by the trace.

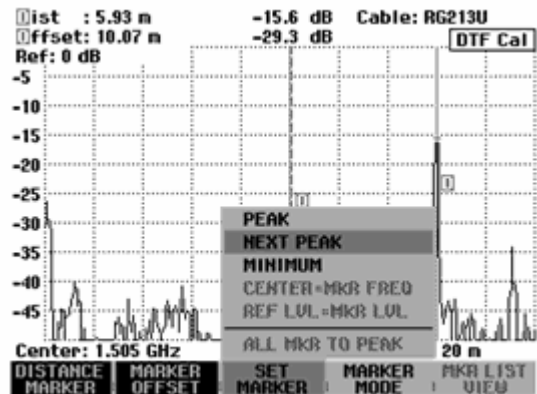

The resolution of cable faults can be increased by a zoom function. This is used primarily with long cables to better distinguish faults that are very close to each other.

- Set the marker on the cable fault to be examined.
- Press the MARKER MODE softkey.
- Using the rotary knob or the cursor keys, select the ZOOM ON menu item.
- Confirm with the ENTER key.

The R&S FSH3-TV zooms the display of the cable fault by the factor 2. The zoom factor is shown in the entry box (here, ZOOM FACTOR: 2).

- To zoom in on the fault even more, increase the zoom factor by turning the rotary knob or entering a higher value.

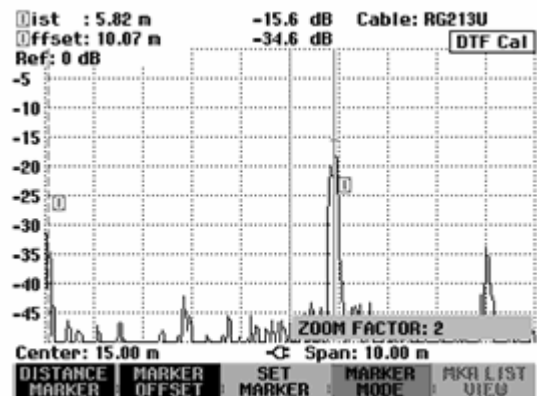

The permissible zoom factor depends on the selected cable length. The minimum span is 3 m.

The screenshot on the right shows the fault from the preceding measurement zoomed by the factor 6. Faults mainly at the end of the cable can thus be clearly distinguished.

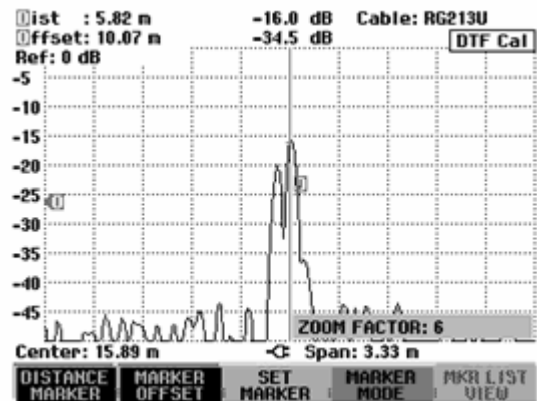

Switch the zoom function off as follows:

- Press the MARKER MODE softkey in the marker menu.
- Using the rotary knob or the cursor keys, select the ZOOM OFF menu item.
- Confirm with the ENTER key or by pressing the MARKER MODE softkey again.

#### Measurement of multiple cable faults using the multimarker function:

If several faults are detected in a cable, the position of each fault can be indicated by a separate marker (distance marker) by using the multimarker function.

- Press the MARKER MODE softkey.
- Using the rotary knob or the cursor keys, select the MULTIMARKER menu item.
- Confirm with the ENTER key or the MARKER MODE softkey.
- Press the DISTANCE MARKER softkey.

A menu with six markers opens.

The following options are possible:

- Select the highlighted marker as the active marker by pressing the ENTER key.
- Select another marker by means of the rotary knob or the cursor keys and confirm your selection with the ENTER key.
- Activate ALL MARKERS ON by means of the rotary knob or the cursor keys.  
All markers are switched on and positioned on the highest values of the trace.

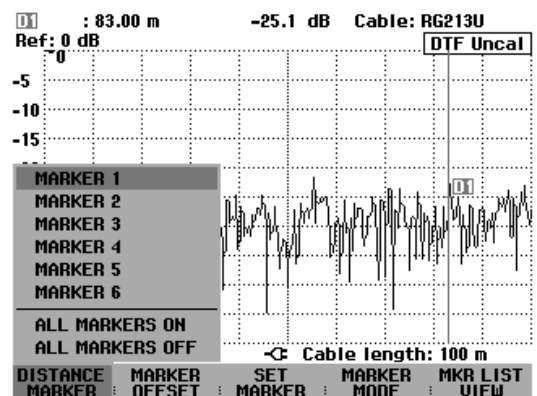

After a marker is activated, its position is indicated in the value entry box. To vary the marker position, use the number keys to enter a distance (e.g. 11.5 m), or move the marker pixel by pixel with the rotary knob, or move it in steps of 10% of the displayed cable length by means of the cursor keys. For fast marker positioning, it is recommended that first coarse adjustment be performed with the cursor keys, and then fine adjustment with the rotary knob.

The value entry box for the marker position is closed when the marker position is confirmed with the ENTER key.

With the MARKER OFFSET function, a new reference plane can be defined for the distance-to-fault measurement. If a marker offset is defined, all distance values output by the R&S FSH3-TV are referenced to the position of the offset marker.

Automatic marker positioning (PEAK, NEXT PEAK, MINIMUM) is always performed on the active marker. The active marker is indicated ahead of the selected function (example: D1: PEAK). The zoom function, too, acts on the active marker.

## Measuring spectrum and reflection

Apart from distance-to-fault measurements for cables, the R&S FSH3-TV also provides an overview measurement for the frequency spectrum and reflections using the same settings – for example the center frequency and span. The spectrum display mode is useful for detecting spurious signals. External signals, e.g. from other transmitters, affect distance-to-fault measurements as they are picked up at the R&S FSH3-TV's RF input and are superimposed on the measurement signal. Reflection measurements are useful, e.g. for checking the matching of an antenna connected to the cable.

➤ Press the MEAS MODE softkey.

The R&S FSH3-TV opens the submenu with the various measurement mode options.

- Select the mode you want using the rotary knob or the cursor keys.
- Confirm your selection by pressing the MEAS MODE softkey again or by pressing the ENTER key.

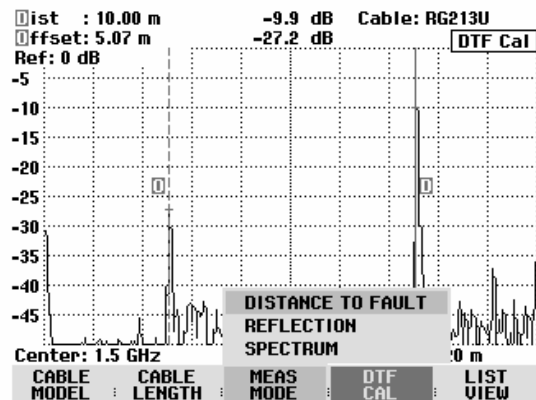

When SPECTRUM is selected, the R&S FSH3-TV turns off the tracking generator and displays the spectrum over the frequency range of the DTF measurement. To indicate that the R&S FSH3-TV is in the spectrum mode, DTF Spectrum is displayed in the top right-hand corner of the screen. Otherwise, the R&S FSH3-TV uses exactly the same settings as it did for DTF measurements.

The spectrum mode is used to check if there are any spurious signals in the frequency range of the DTF measurement. These are most likely to be present if the cable under test is connected to an antenna.

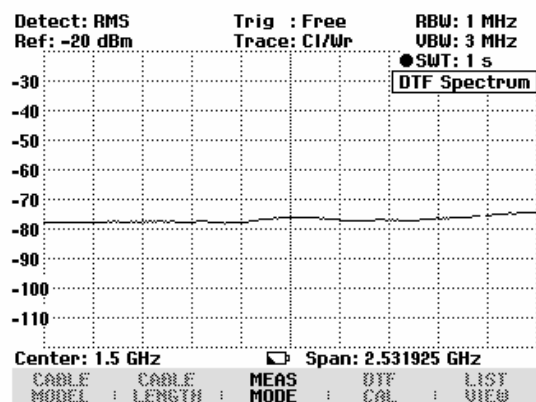

When REFLECTION is selected, the R&S FSH3-TV measures the return loss over the frequency range which has been selected for the distance-to-fault measurement. This means, for example, an antenna can be matched without altering the test setup. The R&S FSH3-TV automatically switches the VSWR Bridge R&S FSH-Z2 over to the VSWR measurement mode if REFLECTION has been selected.

To indicate that the R&S FSH3-TV is measuring return loss, DTF refl. cal is displayed in the top right-hand corner of the screen.

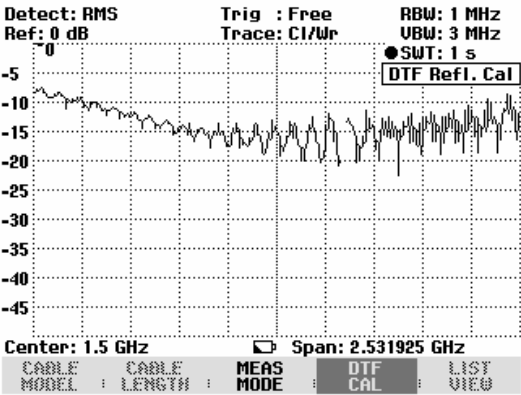



## Further information

### Setting the span

If automatic setting (AUTO SPAN) is used, the R&S FSH3-TV automatically selects the span based on the cable length and cable model entered. The shorter the cable under test, the greater the selected span. If the center frequency is too high or too low for the cable length in question, the R&S FSH3-TV automatically adapts it to the required span.

The R&S FSH3-TV calculates the span from the cable length as follows:

$$\text{Span} = 1023 \cdot \frac{c_0 \cdot v_r}{2 \cdot \text{CL}} \cdot \frac{1024}{2048}$$

where

$c_0$  = velocity of light

$v_r$  = velocity factor of cable

CL = cable length

1024 = number of pixels calculated

2048 = number of pixels included in inverse Fourier transform

If, in the case of short cable lengths, the 3 GHz frequency range of the R&S FSH3-TV is not sufficient to set the span obtained with the above formula, the number of pixels calculated for displaying distance to fault is reduced accordingly.

If the span is set manually, the R&S FSH3-TV calculates 1024 points as in automatic setting. Since, however, not all 1024 points are valid owing to the restricted frequency range, the R&S FSH3-TV displays only as many points as permitted by the span that has been set. Thus, the length resolution decreases and the span is reduced.

The following two screenshots show the measurements of the faults of a 22 m cable at a set cable length of 25 meters, measured once with automatic setting of the span and once with the span reduced to 400 MHz. Both measurements clearly show the cable coupling used at 12 m and the end of the cable which has a 50 Ω termination.

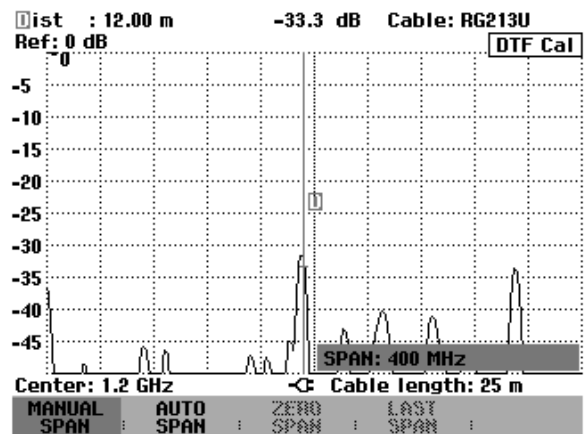
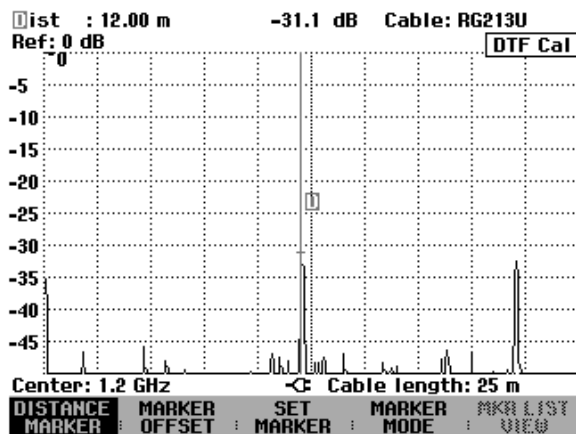

Measurement with automatic setting of the span    Measurement with 400 MHz span  
 (span = 2.025 GHz)

The trace on the right shows the fault location at the end of the cable clearly wider than the left one which was measured with optimum span. The reason is the reduced number of points in the calculation with reduced span. The points in reduced span are calculated using the following formula:

$$N = \frac{\text{SPAN}}{\text{AUTOSPAN}} \cdot 1024,$$

where

N = number of measurement points

SPAN = manually set span

AUTOSPAN = span used by the R&S FSH3-TV in automatic setting of the span

In the above measurement example, the resolution is thus 202 points for a cable length of 25 m, i.e. the distance is approx. 12.4 cm between the two measurement points.

## Selecting the center frequency

The R&S FSH3-TV's center frequency should be as close to the cable under test's operating frequency as possible (for example the transmission frequency of the antenna connected to the cable). Cable attenuation increases with increasing frequency. This means that both the incident wave and the reflected wave from the end of the cable or at any faults is attenuated more at higher frequencies. This restricts the dynamic range at higher center frequencies. Therefore, never select a center frequency that is higher than necessary.

In the case of short cable lengths and automatic setting of the span, the R&S FSH3-TV uses its entire frequency range for the measurement. It automatically uses 1.505 GHz as the center frequency.

After the span is reduced, the R&S FSH3-TV can be set to the desired center frequency.

## Measurement

The R&S FSH3-TV performs a sweep over 1024 test points to measure the sum signal of forward and reflected waveform. It transforms the sum signal in the frequency domain into the time domain by means of the inverse FFT (IFFT). The IFFT has a length of 2048 points. The data set is zero-padded to 2048 points and evaluated by means of a Hamming window before performing the IFFT. The R&S FSH3-TV corrects the result of the IFFT by using the correction values from calibration.

It then calculates the IFFT result into length units from the cable parameters, light velocity and frequency range. In addition, the R&S FSH3-TV considers the attenuation of the cable to be measured in order to display the discontinuities with correct level.

## Length measurement accuracy

The length measurement accuracy is primarily determined by the deviation of the cable data of the cable model from the real cable data. Depending on the cable, the data may exhibit a tolerance of up to 10 %. This deviation directly affects the measurement error. A second factor of influence is the display resolution of the R&S FSH3-TV. Its uncertainty is  $\pm 1/2$  pixel or  $1/2 \times (\text{length}/301)$ .

## Using Limit Lines

Limit lines are used to set limits for level characteristics versus time or versus frequency on the screen; they must not be exceeded. For instance, the upper limits of permissible spurious or harmonics of a DUT are marked by limit lines. In the R&S FSH3-TV, the upper and lower limit value can be preset by way of limit lines. Thus, a spectrum or level characteristic in the time domain (span = 0 Hz) can be checked either visually on the screen or automatically by verifying limit violations.

A limit line consists of at least two and at most 25 value pairs (points) on the x axis (frequency, time or length) and the y axis (level). The R&S FSH3-TV links the individual points by straight lines. The values on the x axis may be specified in absolute units (e.g. frequency in MHz) or relative units referenced to the center of the measured trace (e.g. center frequency). Relative units are of advantage, for instance, when modulated output signals are measured. If the center frequency is varied, the mask on the screen remains unchanged. The points on the y axis are always dB values. If the scale on the y axis is linear (unit V or W), the R&S FSH3-TV automatically switches to the respective dB unit after a limit line has been switched on.

Limit lines are defined with the aid of control software FSH View. They are loaded into the memory of the R&S FSH3-TV via the optical interface. Up to 100 limit lines can be stored simultaneously in the R&S FSH3-TV memory. (The total number of storable limit lines, transducer factors and cable models (option R&S FSH-K2) is 100. If transducer factors or cable models are stored simultaneously, the maximum number of limit lines decreases correspondingly.)

### Operating sequence:

- Press the MEAS key.
- Press the LIMIT LINES softkey.

The softkey menu for the control of limit lines is displayed on the screen.

*N.B.: Limit lines cannot be used for measurements with the Power Sensor R&S FSH-Z1. In this case the LIMIT LINES softkey is blanked.*

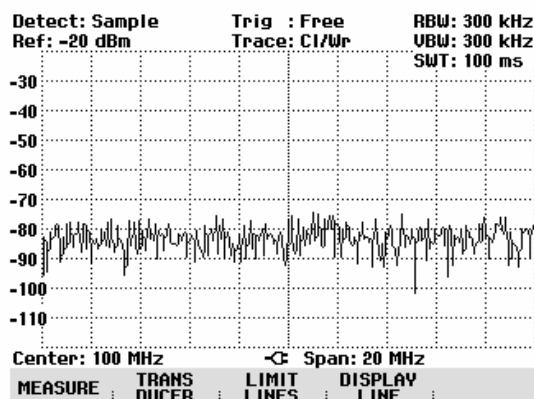

The R&S FSH3-TV makes a distinction between upper limit lines (UPPER LIMIT) and lower limit lines (LOWER LIMIT). It checks whether a measured value is above the upper limit line or below the lower limit line. The limit lines stored in the R&S FSH3-TV can be used to mark both upper and lower limit values.

- Depending on the application, press the UPPER LIMIT or LOWER LIMIT softkey.

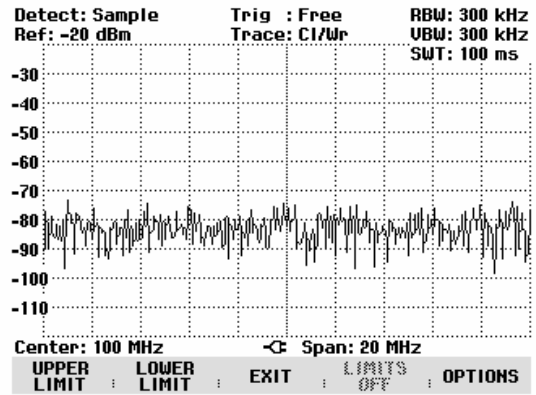

The R&S FSH3-TV displays a list of available limit lines. If no limit line is switched on, the first value in the list is marked. If a limit line has been switched on, the cursor is on the selected item. If no limit lines are stored in the R&S FSH3-TV, NO LIMIT LINES is displayed.

30/11/2002 UPPER LIMIT LIST 10:51:18

PowerMask	freq	rel	dB
New abs	freq	abs	dB
New Line2	freq	rel	dB
New Line	freq	rel	dB
Limit2	freq	abs	dBm
Limit1	freq	abs	dBm
FreqMask2	freq	abs	dBm
Fieldstrength	freq	abs	dBμV/m

The unit of the limit line and the unit currently set on the x axis must be identical. The domain is marked next to the line name in the list to indicate the unit of the individual limit lines.

- freq Frequency (spectrum measurements)
- time Time (zero span measurements)
- dist Distance (DTF = distance-to-fault measurements)

SELECT : LIMIT : EXIT : LIST-> : OFF : PRINTER

It is also indicated whether the limit lines are assigned to absolute frequency, time or distance values (abs) or whether they are specified relative the center of the x axis (rel). In the last column, the unit used for the limit line is displayed.

**Switching on a limit line:**

- Select the desired limit line from the list by means of the cursor keys or the rotary knob.

If the selected limit line does not match the unit currently selected on the x axis, the message "The unit of the limit line doesn't match the unit of the measurement" is displayed on the R&S FSH3-TV. The limit line is not switched on.

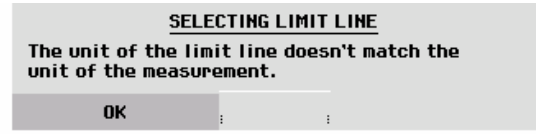

- Press SELECT to switch on the chosen limit line.

**Switching off a limit line:**

- Press the LIMIT OFF softkey to switch off the limit line.

**Exiting the list of limit lines:**

- Press the EXIT softkey to close the list of limit lines.

After a limit line has been switched on, the R&S FSH3-TV returns to the menu and the selected line is displayed in the diagram. The name and type of the limit line are also marked (UPPER for an upper limit line and LOWER for a lower line). To show which limit line is active, the respective softkey (UPPER LIMIT or LOWER LIMIT) is displayed in green.

If the limit line menu is quit with EXIT or with a key that opens another menu, the information on the limit line disappears. The name and type of active limit lines can thus be quickly viewed by calling the limit line menu.

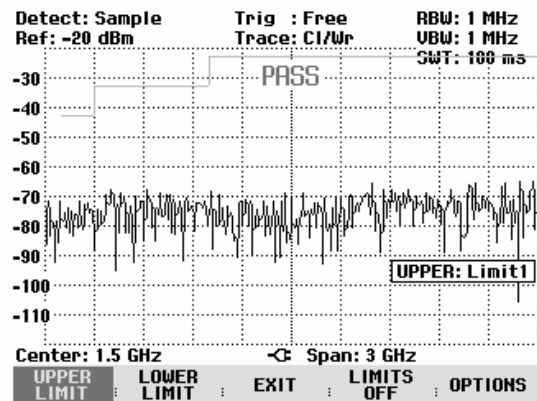

All active limit lines can be switched off together with the LIMITS OFF softkey.

## Measurements with limit lines

During a measurement, the R&S FSH3-TV checks the trace after each frequency sweep for upper and lower limit violations. If all measured values are within specified limits, PASS is displayed at the top in the center of the diagram. FAIL is indicated even if only a single measured value (= pixel of the trace) exceeds a limit value. As long as a decision about limit violations cannot be made, e.g. because a sweep is not completed, "?" is displayed instead of PASS or FAIL.

The automatic limit check can be switched off in the OPTIONS menu. A limit violation can also be indicated by an acoustic signal.

### PASS/FAIL information:

- Press the OPTIONS softkey.
- Select MESSAGE... with the rotary knob or the cursor keys.
- Select ON or OFF with the rotary knob or the cursor keys and confirm the selection with the OPTIONS softkey or with the ENTER key.

The R&S FSH3-TV switches the PASS/FAIL information in the diagram off or on.

### Beep:

- Press the OPTIONS softkey.
- Select BEEP... with the rotary knob or the cursor keys.
- Select ON or OFF with the rotary knob or the cursor keys and confirm the selection with the OPTIONS softkey or with the ENTER key.

If BEEP has been selected, the R&S FSH3-TV outputs a beep each time a limit is exceeded.

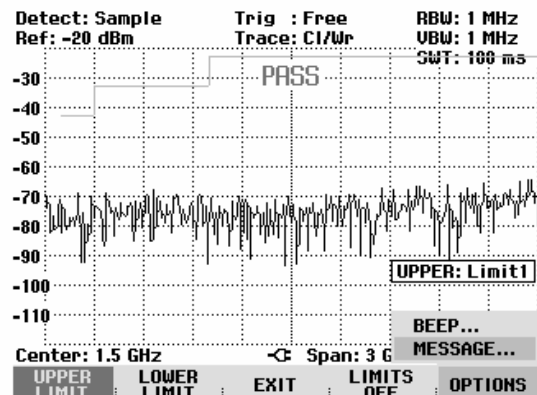

## **Definition range of limit lines**

If a limit line is not defined in the entire frequency range or displayed span, a check is not performed outside the definition range.

## **Data sets containing limit lines**

The R&S FSH3-TV stores data sets together with any limit lines that may have been active for the measurement in question. When such a data set is recalled, the associated limit lines are available too. They do however not appear in the list of limit lines.

## Measuring with Transducer Factors

The frequency-dependent transducer factor of transducers and antennas can be directly considered in the measurement result. A transducer factor consists of a numeric values and a unit. The R&S FSH3-TV corrects the level values of the trace by the values of the transducer. At the same time, the unit of the transducer is assigned to the level axis. When field-strength measurements are performed with the aid of antennas, for instance, the electrical field strength is directly indicated in dB $\mu$ V/m on the R&S FSH3-TV. A transducer factor can also be used to correct a frequency-dependent attenuation, e.g. of a cable between DUT and RF input of the R&S FSH3-TV.

Up to 100 transducer factors with 60 reference values each can be stored internally. (The total number of storable limit lines, transducer factors and cable models (option R&S FSH-K2) is 100. If limit lines or cable models are stored simultaneously, the maximum number of transducer factors decreases correspondingly.)

Interpolation between the values is performed with the aid of a modified spline algorithm. Even if only relatively few values such as maxima, minima and turning points are available, this algorithm can easily simulate the correction factors of common transducers. Two transducers can be switched on at a time. The second transducer must be assigned the unit dB. The R&S FSH3-TV adds the two transducers to a total transducer.

Transducer factors are defined with the aid of control software FSH View. They are transferred from the PC to the instrument via the optical RS-232-C interface.

Units supported for transducer factors:

- dB
- dB $\mu$ V/m
- dB $\mu$ A/m

The unit dB does not change the unit set on the R&S FSH3-TV. It can be used, for instance, to compensate for frequency-dependent loss and gain at the input of the R&S FSH3-TV. The units dB $\mu$ V/m and dB $\mu$ A/m convert the output power of an antenna into electric or magnetic field strength.

For example, to compensate for the cable loss between the transducer and the RF input, the R&S FSH3-TV can use two transducers at the same time. One of them must have the unit dB, however, i.e. it must correspond to one loss or gain value.

**Operating sequence:**

- Press the MEAS key.
- Press the TRANSDUCER softkey.

The softkey menu for operation of transducer factors is displayed on the screen.

*N.B: Transducer factors are not available for measurements with the tracking generator and the Power Sensor R&S FSH-Z1. The TRANSDUCER softkey is therefore interactive.*

Two transducer factors can be switched on with the TRANSD and TRANSD dB softkeys. With EXIT the transducer menu can be quit; with TRD'S OFF all transducer factors can be switched off.

- Press the TRANSD softkey.

The R&S FSH3-TV displays a list of transducer factors available in the unit. The cursor is on the active transducer factor (line highlighted). If no transducer is active, the cursor is on the first item in the list.

- Select the desired transducer factor with the rotary knob or the cursor keys and switch it on with the SELECT softkey.
- Switch off an active transducer factor with the TRANSD OFF softkey

or

- Quit the transducer menu with the EXIT softkey.

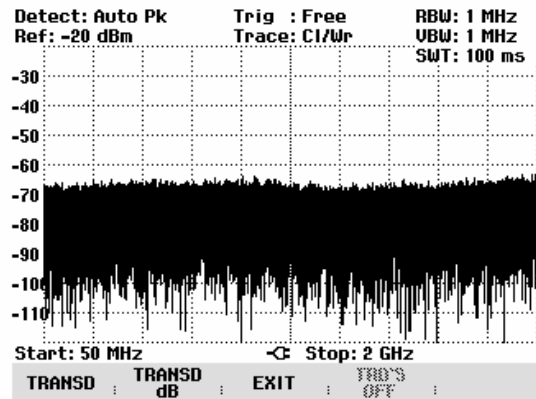

30/11/2002	TRANSDUCER LIST	10:09:19
RAM	dB	30/10/2002 11:48:44
PreAmp	dB	30/10/2002 11:48:44
HL223	dBµV/m	30/10/2002 11:48:44
HK116	dBµV/m	30/10/2002 11:48:44
HE200P-HF	dBµV/m	30/10/2002 11:48:44
HE200P-500-3000	dBµV/m	30/10/2002 11:48:44
HE200P-200-500	dBµV/m	30/10/2002 11:48:44
HE200P-20-200	dBµV/m	30/10/2002 11:48:44
HE200A-HF	dBµV/m	30/10/2002 11:48:44
HE200A-500-3000	dBµV/m	30/10/2002 11:48:44
HE200A-200-500	dBµV/m	30/10/2002 11:48:44
HE200A-20-200	dBµV/m	30/10/2002 11:48:44
CBL6111	dBµV/m	30/10/2002 11:48:42

SELECT : TRANSD OFF : EXIT : LIST-> PRINTER

When LIST->PRINTER is pressed, the R&S FSH3-TV outputs the list of transducer factors to a printer.



If a transducer is switched on, TRD is displayed in the top right-hand corner of the diagram on the R&S FSH3-TV.

The complete name of the selected transducer is displayed in the status line (press the STATUS key and scroll downward in the list), or in the list of transducer factors (entry highlighted in red).

The example (Fig. right) shows the transducer factor of the R&S HL223 antenna, which is defined as between 200 MHz and 1300 MHz. The R&S FSH3-TV therefore displays the noise in this frequency range as a function of frequency incremented by the transducer factor. Outside the transducer range, the R&S FSH3-TV sets the transducer factor at zero, i.e. measurements in this range do not yield conclusive results.

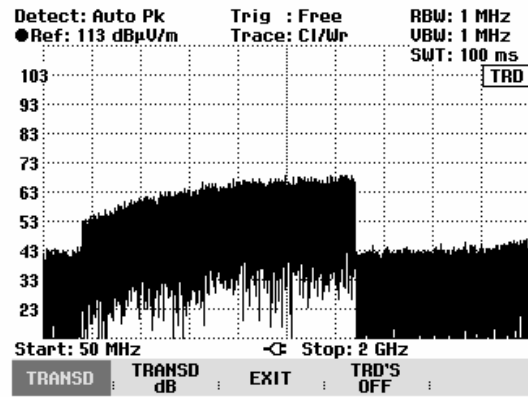

A second transducer factor can be switched on with the TRANSD dB softkey, which is then added to the first. The unit of the second transducer factor must always be the relative unit dB as otherwise an addition would not be useful. When TRANSD DB is selected, the R&S FSH3-TV offers only the transducer factors stored in the instrument with dB as the unit.

## Unit for measurements with transducers

If the unit of the transducer is dB, the units dBm, dBmV or dBµV remain unchanged. The linear units Volt and Watt are not permissible. They are deactivated in the units menu.

If the unit of the transducer is dBµV/m or dBµA/m, this unit is also used for the R&S FSH3-TV level display. This means that both the level axis of the diagram and the level at the marker position are assigned the unit of the transducer. If dBµV/m is selected as the transducer unit, switchover to absolute level indication in V/m is possible.

Switchover to V/m level indication:

- Press the AMPT key.
- Press the UNIT softkey.
- In the UNIT menu, select V by means of the rotary knob or the cursor keys and confirm with the ENTER key or by pressing the UNIT softkey again.

If a transducer with the unit dBµA/m is switched on, no other unit can be selected in the AMPT menu. Level indication is entirely in dBµA/m.

## Reference level settings for measurements with transducers

The transducer shifts the trace by its value as a function of frequency. Positive transducer values increase the level, negative values reduce it. To ensure that the trace is always within the diagram, the R&S FSH3-TV adjusts the reference level accordingly. The reference level is shifted by the maximum transducer value in the positive or negative direction.

## **Frequency range of transducer**

If the set frequency range is wider than the span in which a transducer is defined, the R&S FSH3-TV assumes the transducer values outside the defined range to be zero.

## **Data sets containing transducer factors**

The R&S FSH3-TV stores data sets together with any transducer factors that may have been active for the measurement in question. When such a data set is recalled, the associated transducer factor(s) are switched on as well. Transducer factors recalled as part of a data set do however not appear in the list of transducer factors.

## Saving and Loading Instrument Settings and Measurement Results

The R&S FSH3-TV's settings and measurement results can be saved to the internal memory and recalled at a later date. Using the **R&S FSH View** software package, these data sets can also be saved to a PC from the R&S FSH3-TV or downloaded onto the R&S FSH3-TV from a PC.

Results and settings, including the measurement function, are always saved en bloc so that when the results are recalled the measurement context is clear. The R&S FSH3-TV can store a maximum of 100 data sets which are assigned a unique name.

Data sets for scalar transmission and reflection measurements can be stored along with their calibration data. When such data sets are recalled, therefore, measurements can be performed without prior calibration. Saving a data set with calibration data, however, requires twice as much memory space as without it, i.e. a data set with calibration data takes up the space required for two data sets without calibration data. This reduces the maximum number of data sets that can be stored by the number of data sets stored with calibration data.

Storage of calibration data can be selected in the SETUP menu (see Chapter 2, section "Saving Calibration Data").

➤ Press the SAVE / PRINT key.

The R&S FSH3-TV opens the SAVE / PRINT menu where the functions for saving, clearing and loading data sets are displayed for selection.

A screenshot can also be output to a printer.

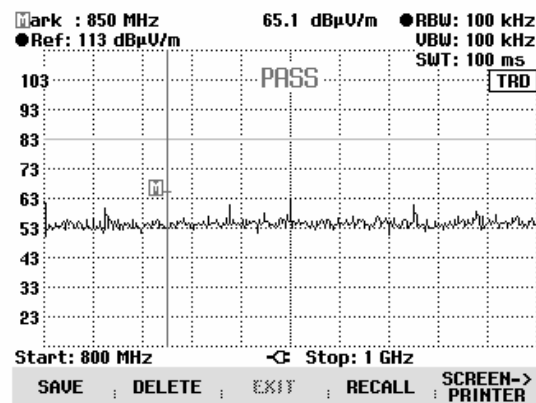

## Saving results

➤ Press the SAVE softkey.

The R&S FSH3-TV opens a text box and prompts the user to enter a name for the data set.

The **Name** entry box, which is highlighted in red, also suggests a name for the data set (DATASET.000) which can be accepted by pressing the ENTER key.

For the sake of simplicity, the R&S FSH3-TV also saves the data set when the SAVE softkey under the suggested name is pressed twice.

The remaining free memory locations (**Free Locations**) are also displayed in the text box.

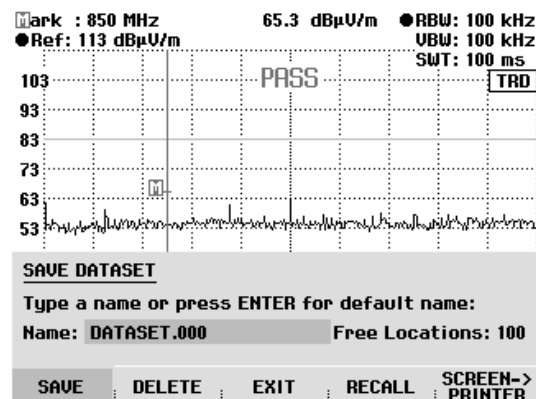

## ***R&S FSH3-TV Saving and Loading Instrument Settings and Measurement Results***

The data set name comprises a text section and a numeric extension, which are separated by a full stop. The data set name suggested by the R&S FSH3-TV is derived from the name of the data set last stored, the numeric extension being incremented by 1 in each case.

This means that consecutive data set names can be assigned by simply saving with SAVE or ENTER.

The names of the data sets already stored can be displayed one after the other using the BACK key. This allows, for example, to store new results under the name of a previous data set (for example Antenna.000), but with a new extension. The R&S FSH3-TV displays the old name together with the first unassigned extension, e.g. Antenna.001. No new name has to be entered.

### **Entering a data set name**

A new name can be entered with the numeric keypad. The letter assignment for the keypad is the same as that for a mobile phone

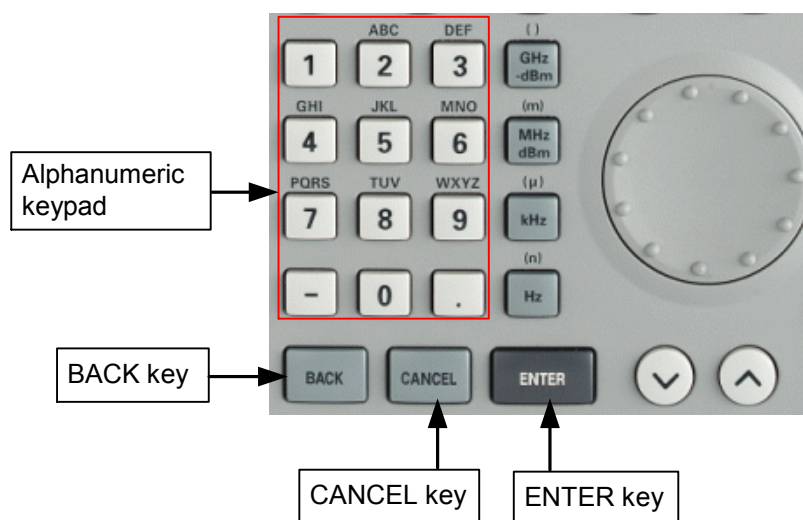

If the R&S FSH3-TV is expecting a letter entry, it automatically assigns the letters above the keys to the keys in the alphanumeric keypad. The keys have a multiple assignment. Enter the letter you want by pressing the key in question the appropriate number of times.

- Using the alphanumeric keypad enter a name for the data set and terminate the entry with the ENTER key.

The data set is saved to the R&S FSH3-TV's internal memory under the name that has been given.

## Loading measurement results

Previously saved measurement results and settings can be recalled with the R&S FSH3-TV's recall function.

- Press the RECALL softkey.

The R&S FSH3-TV opens a list of all the data sets that have been saved (DATASET LIST).

30/11/2002	DATASET LIST	11:07:36
DATASET.002	30/11/2002 11:07:20	
DATASET.001	30/11/2002 11:07:13	
DATASET.000	30/11/2002 11:05:20	

The red selection bar indicates the last data set to have been saved.

Using the cursor keys, you can position the selection bar at the top or bottom of the page. This means fast scrolling if many data sets have been saved in the R&S FSH3-TV's memory.

The displayed list of data sets can be printed out by pressing the LIST->PRINTER softkey.

DELETE ALL	DELETE	EXIT	RECALL	LIST-> PRINTER
------------	--------	------	--------	----------------

You can quit the menu by pressing the EXIT softkey. The R&S FSH3-TV returns to its previous settings.

- Using the rotary knob or the cursor keys select a data set.

- Load the data set by pressing the RECALL softkey.

The R&S FSH3-TV displays the contents of the selected data set as a graph on the screen but the settings are not activated on the R&S FSH3-TV. This provides an opportunity to visually inspect the data set before its settings are activated.

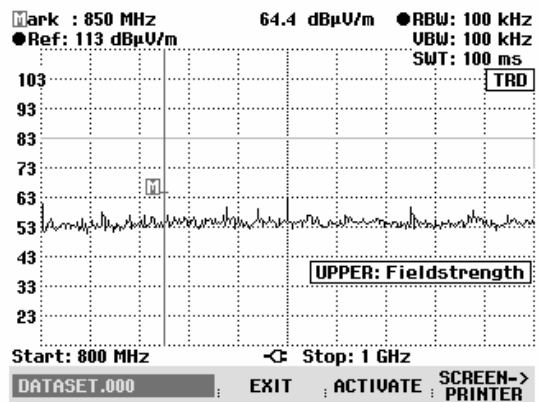

The name of the data set is displayed in the bottom left-hand corner of the screen.

When this setting is activated, you can scroll through the data sets stored by the R&S FSH3-TV with the cursor keys or the rotary knob. This means that the results and the associated settings can be viewed together.

➤

The user can now

- transfer the data set with ACTIVATE and with this setting return to the associated R&S FSH3-TV measurement mode,
- print out the measurement and settings stored in the data set to a printer using PRINT,
- press EXIT to quit the setting again.

When you press the EXIT softkey, you return again to the display mode where all saved data sets are listed (DATASET LIST). You can then select, load or delete data sets from this list.

## Deleting saved data sets

Saved data sets can be selected from the DATASET LIST and individually deleted.

The R&S FSH3-TV marks the selected data set with the red selection bar.

Using the cursor keys, the selection bar is placed at the top or the bottom of the page. This facilitates fast scrolling if many data sets are stored in the R&S FSH3-TV's memory.

The displayed data set list can be printed out by pressing the LIST->PRINTER softkey.

You can quit the menu again by pressing the EXIT softkey. You then return to the previous R&S FSH3-TV setting.

11/12/2002	DATASET LIST	21:29:29
DATASET.005	11/12/2002 21:28:10	
DATASET.004	11/12/2002 21:28:09	
DATASET.003	11/12/2002 21:28:07	
DATASET.002	07/12/2002 19:53:23	
DATASET.001	07/12/2002 19:53:23	
DATASET.000	07/12/2002 19:53:21	

DELETE ALL	: DELETE	: EXIT	: RECALL	: LIST-> PRINTER
------------	----------	--------	----------	------------------

- Using the rotary knob or the cursor keys, select a data set.
- Delete the data set with the DELETE softkey.

The data set is cleared from the R&S FSH3-TV's memory and removed from the list.

## Deleting all data sets

Starting from the DATASET LIST mode, all the data sets in the R&S FSH3-TV's memory can be completely deleted by pressing the DELETE ALL DATASETS softkey.

- Press the DELETE ALL DATASETS softkey.

Before all the data sets are deleted, the R&S FSH3-TV asks the user if he is sure that he wants to delete all the data sets.

The deletion of all data sets must be confirmed explicitly by pressing the YES softkey.

Deletion is aborted if the NO softkey is pressed – the same happens with the ENTER key to prevent accidental deletion of all the data sets.

11/12/2002	DATASET LIST	21:28:45
DATASET.005	11/12/2002 21:28:10	
DATASET.004	11/12/2002 21:28:09	
DATASET.003	11/12/2002 21:28:07	
DATASET.002	07/12/2002 19:53:23	
DATASET.001	07/12/2002 19:53:23	
DATASET.000	07/12/2002 19:53:21	

<b>DELETE ALL DATASETS</b>	
Do you really want to delete all datasets?	
NO	YES

## Printing out Measurement Results

An R&S FSH3-TV screenshot can be printed out on a printer. The printer type and the baud rate for the serial connection can be selected in the setup menu using the GENERAL / PRINTER... softkey.

➤ Press the SAVE / PRINT key.

The R&S FSH3-TV opens the SAVE / PRINT menu and the printout function offers to print out the current screen to a printer.

Instrument settings can also be saved and data sets loaded or deleted.

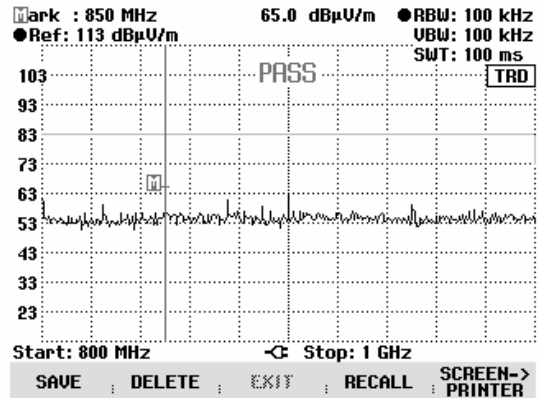

➤ The SCREEN->PRINTER softkey starts the screenshot printout on a printer.

The screenshot printout is black and white.

The print date and time and the measurement date and time are output in the two header lines.

The associated setup parameters for the measurement in question are printed out below the screenshot hardcopy.

Printed at : 01/02/2002 15:27:15  
 Measured at: 01/02/2002 15:15:16

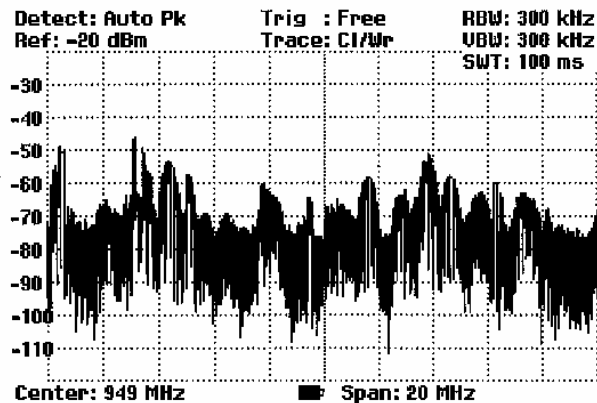

Center Frequency : 949 MHz  
 Span : 20 MHz  
 Reference Level : -20 dBm  
 Reference Offset : 0.0 dB  
 RF Input Reference : 50 Ω

Resolution Bandwidth : 300 kHz  
 Video Bandwidth : 300 kHz  
 Sweptime : 100 ms

Trigger Mode : Free run  
 Trigger Level : ---  
 Trigger Delay : ---  
 Trace Mode : Clear / Write  
 Detector : Auto peak

## How a spectrum analyzer operates

Basically, an RF signal can either be analyzed in the time domain or in the frequency domain.

In the time domain, how the signal varies with time can be observed on an oscilloscope, for example. In the frequency domain, a spectrum analyzer can be used to display the frequency components of a signal.

Both modes are essentially equivalent because applying the Fourier transform to any signal converts it into its spectral components. However, depending on the signal characteristic to be measured, one method is usually more appropriate than the other. Just by glancing at an oscilloscope, it is possible to tell whether a measurement signal is a sine signal, a squarewave with a certain on/off ratio or a sawtooth. However, it is not at all obvious what the harmonic content of the signal is or if low-level signals are superimposed. This is easy to see with a spectrum analyzer.

The following Fig. shows the theoretical basis of the two measurement techniques. In the time domain, an oscilloscope is showing a section of a signal which is approximately a squarewave. The same signal viewed with a spectrum analyzer shows a line spectrum, i.e. the fundamental and harmonics.

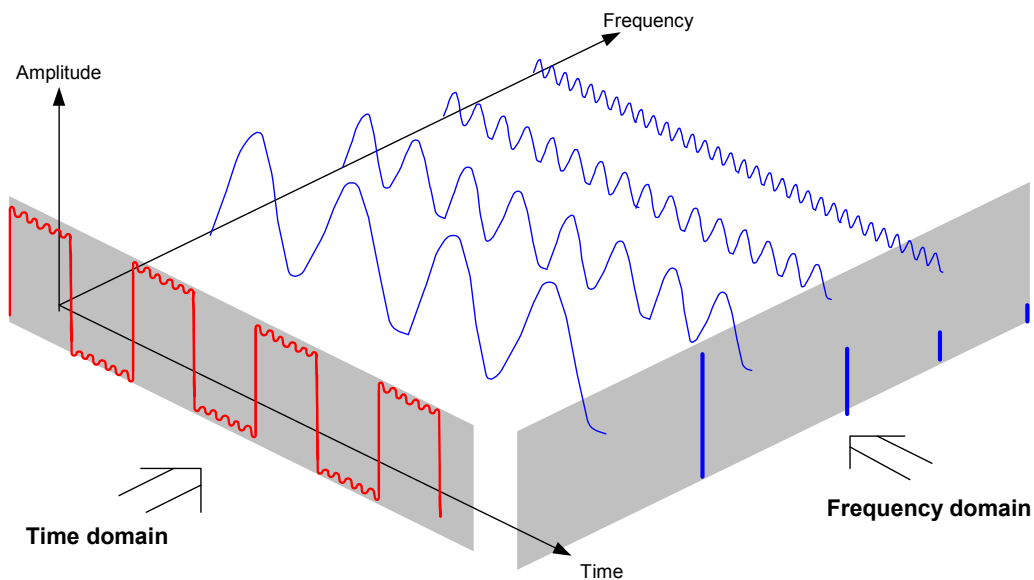

The periodic squarewave in the time domain can be Fourier transformed to the frequency domain. In the case of a squarewave there is a fundamental (= frequency of the squarewave) and its odd harmonics. Using a narrow bandpass filter, the spectrum analyzer makes measurements in the frequency domain. Only at frequencies where there is a signal is there a reading which gives the amplitude of the frequency component.



The block diagram below shows how a spectrum analyzer works.

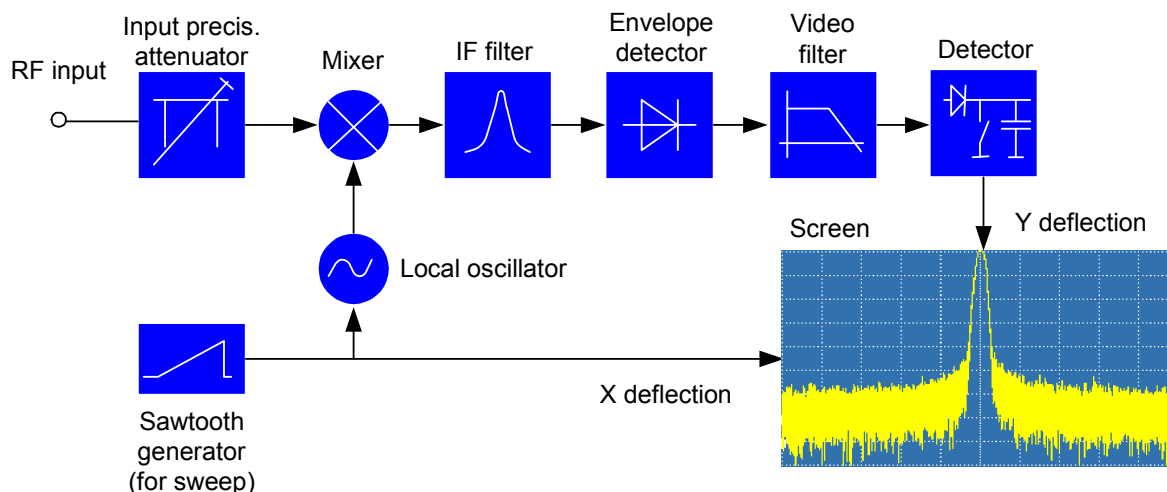

The precision attenuator at the input of the spectrum analyzer adjusts the level of the measurement signal to the level range that the mixer can handle without overdriving it. The precision attenuator at the input of the R&S FSH3-TV is adjustable in 10 dB steps from 0 dB to 30 dB and is directly coupled to the reference level setting.

The mixer converts the RF input signal to a fixed IF. Conversion is usually performed in several stages to an IF for which good narrowband IF filters are available. The R&S FSH3-TV has three mixing stages with the IFs 4031 MHz, 831.25 MHz and 31.25 MHz.

A local oscillator that can be tuned from 4031 MHz to 7031 MHz is used in the R&S FSH3-TV for conversion to the first IF so that a certain input frequency is converted to the first IF. The further conversions are performed by single-frequency oscillators.

The frequency of the local oscillator determines the input frequency at which the spectrum analyzer performs measurements:

$$f_{in} = f_{LO} - f_{IF}$$

The first mixer produces the sum frequency  $f_{LO} + f_{in}$  (= image frequency  $f_{image}$ ) as well as the difference frequency  $f_{LO} - f_{in}$ .

The image frequency is rejected by the bandpass at the IF so that it does not interfere with the subsequent frequency conversions.

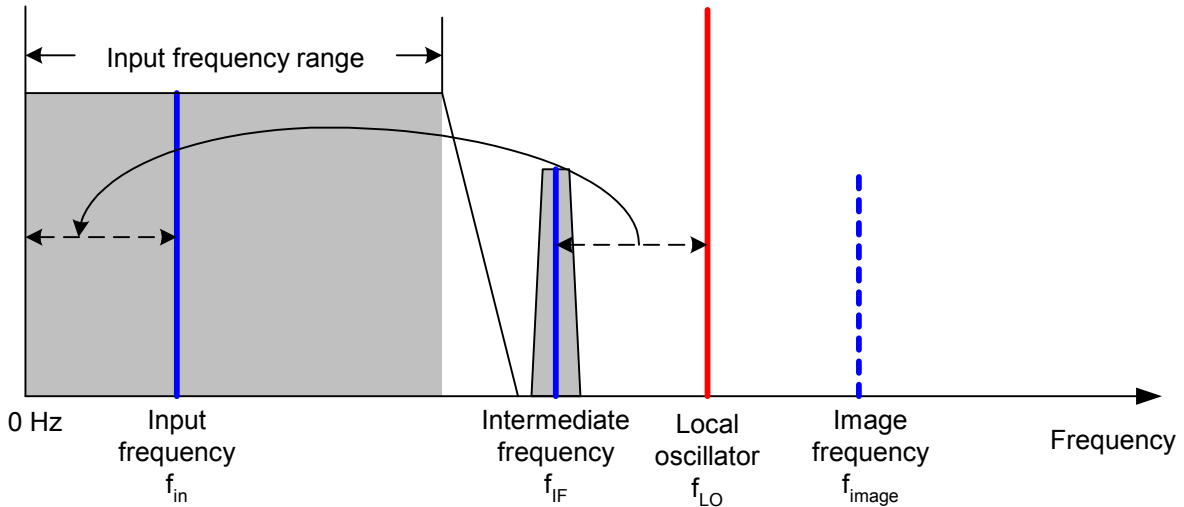

The first local oscillator is tuned with a sawtooth which simultaneously acts as the x deflection voltage for the display. In practice, synthesizer technology is used to generate the frequency of the first local oscillator and for a digital display.

The instantaneous sawtooth voltage therefore determines the input frequency of the spectrum analyzer.

The bandwidth of the IF filter at the IF determines the bandwidth that is used for measurements. Pure sine signals are passed by the IF filter characteristics. This means that signals closer together than the bandwidth of the IF filter cannot be resolved. This is why the bandwidth of the IF filter in a spectrum analyzer is referred to as the resolution bandwidth. The R&S FSH3-TV has resolution bandwidths from 100 Hz to 1 MHz.

The bandlimited IF is passed to the envelope detector. The envelope detector removes the IF from the signal and outputs its envelope. The output signal from the envelope detector is referred to as the video signal. As it has been demodulated, it only contains amplitude information. The phase information is lost.

With RF sine signals, the video signal is a DC voltage. With AM signals the video signal contains a DC component whose amplitude corresponds to the carrier power and an AC component whose frequency is equal to the modulation frequency, provided the modulation frequency is inside the resolution bandwidth.

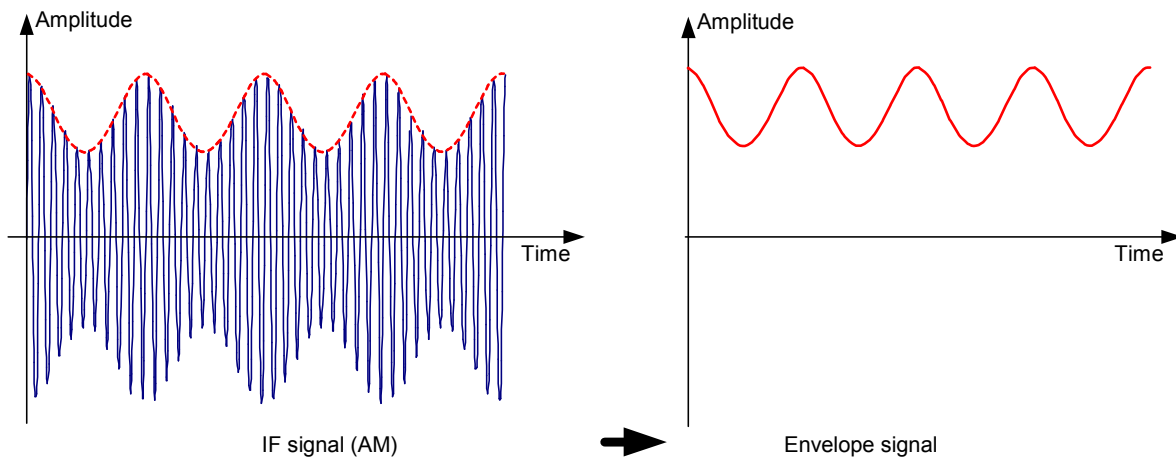

The video filter comes after the envelope detector. The filter is a lowpass with an adjustable cutoff frequency which limits the bandwidth of the video signal. It is particularly useful when sine signals are to be measured in the vicinity of the spectrum analyzer's intrinsic noise. The sine signal produces a video signal that is a DC voltage. At the IF, however, the noise is distributed over the whole bandwidth or, in the case of the video signal, over half the bandwidth of the resolution filter. By selecting a narrow video bandwidth relative to the resolution bandwidth, the noise can be suppressed, while the sine signal to be measured (= DC) is not affected.

The Figs. below show a weak sine signal. In the first Fig., it is measured with a large video bandwidth and in the second with a narrow video bandwidth.

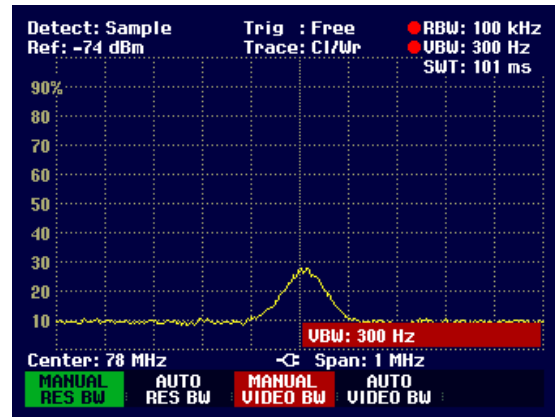
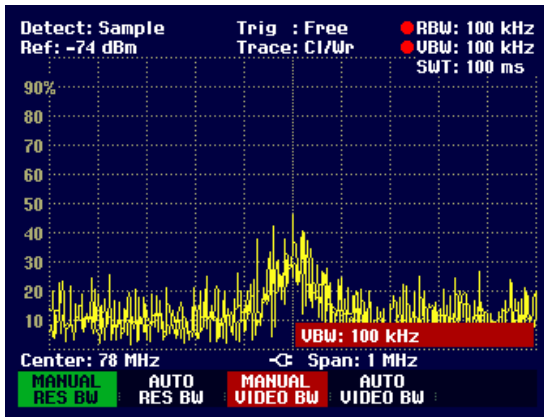

Limiting the video bandwidth smooths the trace considerably. This makes it much easier to determine the level of the measured signal.

The detector comes after the video filter. The detector combines the measured spectrum so that it can be represented as one pixel in the trace. The R&S FSH3-TV uses 301 pixels to form the trace, i.e. the whole measured spectrum has to be represented using just 301 pixels. Common types of spectrum analyzer detectors are the peak detector (PEAK), the sample detector (SAMPLE) and the RMS detector (RMS). An Auto Peak detector which simultaneously displays the maximum peak and the minimum peak is usually also provided. The Fig. below explains how these detectors work.

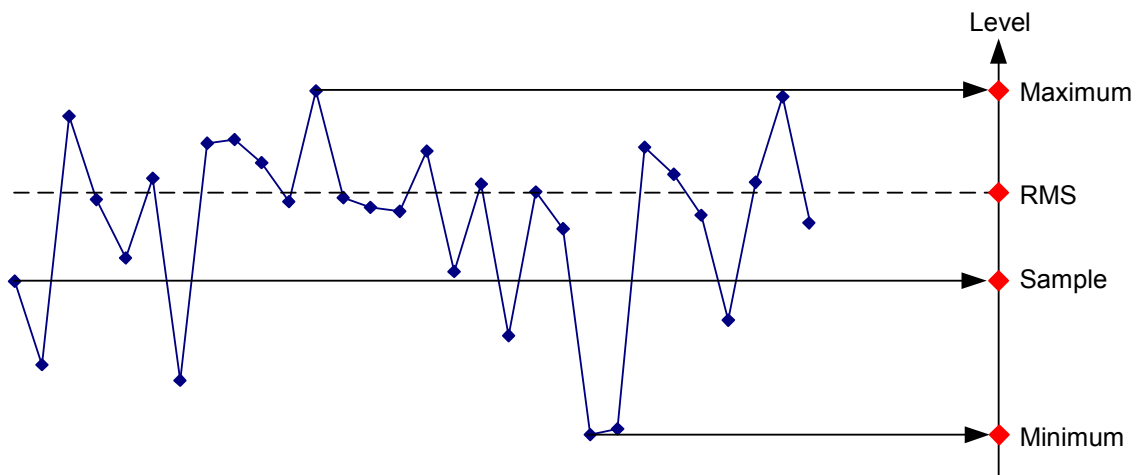

The Fig. above shows 30 measured values which are represented by a single pixel. The peak detector determines and displays the maximum measured value. The Auto Peak detector takes the maximum and minimum and displays them together. The two values are joined by a vertical line segment. This gives a good indication of the level variation over the measured values represented by a single pixel. The RMS detector is used by the spectrum analyzer to determine the RMS value of the measured values. It is therefore a measure of the spectral power represented by a pixel. The sample detector takes an arbitrary measurement value and displays it (in the Fig. above, the first). The other measured values are ignored.

On the basis of the operating principles of detectors, a few recommendations can be made as to their use.

- It is best to use the Auto Peak detector or the peak detector for spectrum analysis over large frequency ranges. This ensures that all signals are displayed.
- The RMS detector is recommended for power measurements on modulated signals. However, the display range should be chosen so as not to exceed 100 times the bandwidth of the signal or the resolution bandwidth, whichever is larger.
- The sample detector or the RMS detector (preferred) should be used for noise measurements. Only these two detectors are capable of measuring noise power correctly.
- When measurements are made on sine signals, the level display does not depend on the detector. However, if you use the RMS detector or the sample detector, ensure that the span is not too great. Otherwise, the displayed levels of sine signals may be lower than their true value.